

Ingersoll

**ELECTRICAL SYSTEM
MODEL 226, 446, 448, 646, 648
Service Manual No. 9-51721**

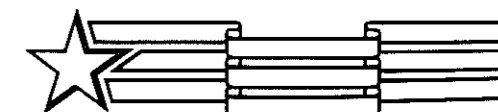

QUALITY IN THE AMERICAN TRADITION

TABLE OF CONTENTS

Safety Messages	3
Introduction	4
Test Equipment	4
Wiring Diagrams	5-9
Troubleshooting Chart	10-12
Battery Care and Maintenance	13-16
Battery Check Sheet	16
Starter Motor Repair	17-24
For Models 226, 446, 448, 648	17-19
For Model 646	20-24
Flywheel Alternator	25
Ignition	25-28
Breaker Points Service	25
Ignition Timing Procedure	26
Coil Service	27
Condenser Service	27
Spark Plug	28

SAFETY MESSAGES



This safety alert symbol indicates Important Safety Messages in this manual. When you see this symbol carefully read the message that follows and be alert to the possibility of personal injury or death.



POISON: Batteries contain sulfuric acid which can cause severe burns. Avoid contact with skin, eyes or clothing. Antidote - external flush with water - internal drink large quantities of water or milk. Follow with Milk of Magnesia, beaten egg or vegetable oil. Call physician immediately. Eyes flush with water for 15 minutes and get prompt medical attention. Keep out of reach of children.



CAUTION: When removing a battery always disconnect the negative (ground) cable first. When installing the battery always connect the negative (ground) cable last. This will prevent accidental grounding of wrench when disconnecting or connecting the positive cable. Place all electrical switches in the 'off' position.



CAUTION: Think out your circuit before you make or break a connection. A wrong connection can be painful and expensive.



DANGER: Charging batteries produce explosive hydrogen gas. Keep sparks, flames and cigarettes away. Ventilate when charging or using in enclosed space. Always shield eyes when working near batteries. Explosion of hydrogen gas can cause serious injury.



CAUTION: When working around storage batteries remember that all exposed metal parts are "live". Never lay a metal object across the terminals as a spark or short circuit may result.



CAUTION: Put transmission and attachment drive controls in neutral before attempting to troubleshoot the electrical system. Unexpected machine movement can cause injury.



CAUTION: Storage areas for batteries must be well ventilated to prevent accumulation of hydrogen gas from newly recharged batteries.



WARNING: To jump start this machine, connect positive jumper cable to battery terminal on starter solenoid and connect negative jumper cable to good engine ground. Start engine only when seated in operator's seat. Stop engine before leaving machine. Disconnect jumper cables. Any other method could result in uncontrolled machine movement.



CAUTION: Never wear rings or metal watch bands that may ground a live circuit. Severe burns may result.

INTRODUCTION

This Service Manual Section applies to tractors and loaders equipped with Onan engines.

TRACTOR MODEL	
226	ALL
446	ALL
448	ALL
646	ALL
648	ALL

TEST EQUIPMENT

The following listing is the minimum suggested test equipment needed to perform the troubleshooting steps outlined in this service manual section.

1. VOM Meter

A Volt-Ohm-Milliamp Meter with the following ranges:

- Volts - AC - 0 to 30 - Used for measuring alternator - stator output.
- Volts - DC - 0 to 1 - Used for measuring voltage drops in circuitry.
- Volts - DC - 0 to 20 - Used for measuring battery charging voltage.
- mA - DC - 0 to 3 - Used for measuring current leakage.
- Ohms - Rxl - Used for measuring low resistance values such as stator windings, primary ignition coil winding.

Ohms - RX1000- Used for measuring higher resistance values such as in ignition coil secondary windings.

Several suitable meters are:

- Radio Shack Model 22-202 and Model 22-203
LaFayette Model 99R50734 and Model 99R50841
- 2. An automotive type ampmeter such as, Ingersoll Part Number C18389, with leads and alligator clips.
- 3. Spark Tester, such as, Briggs and Stratton Part Number 19051.
- 4. Clip on ampmeter
- 5. Jumper leads 24" long, 14 gauge wire with alligator clips.
- 6. 12 Volt test light
- 7. Battery Hydrometer
- 8. DC Power Timing Light

226 - 446 - 448 TRACTOR WIRING DIAGRAM

226 - PIN 14094020 AND AFTER
446 - PIN 14096200 AND AFTER
448 - PIN 14097625 AND AFTER

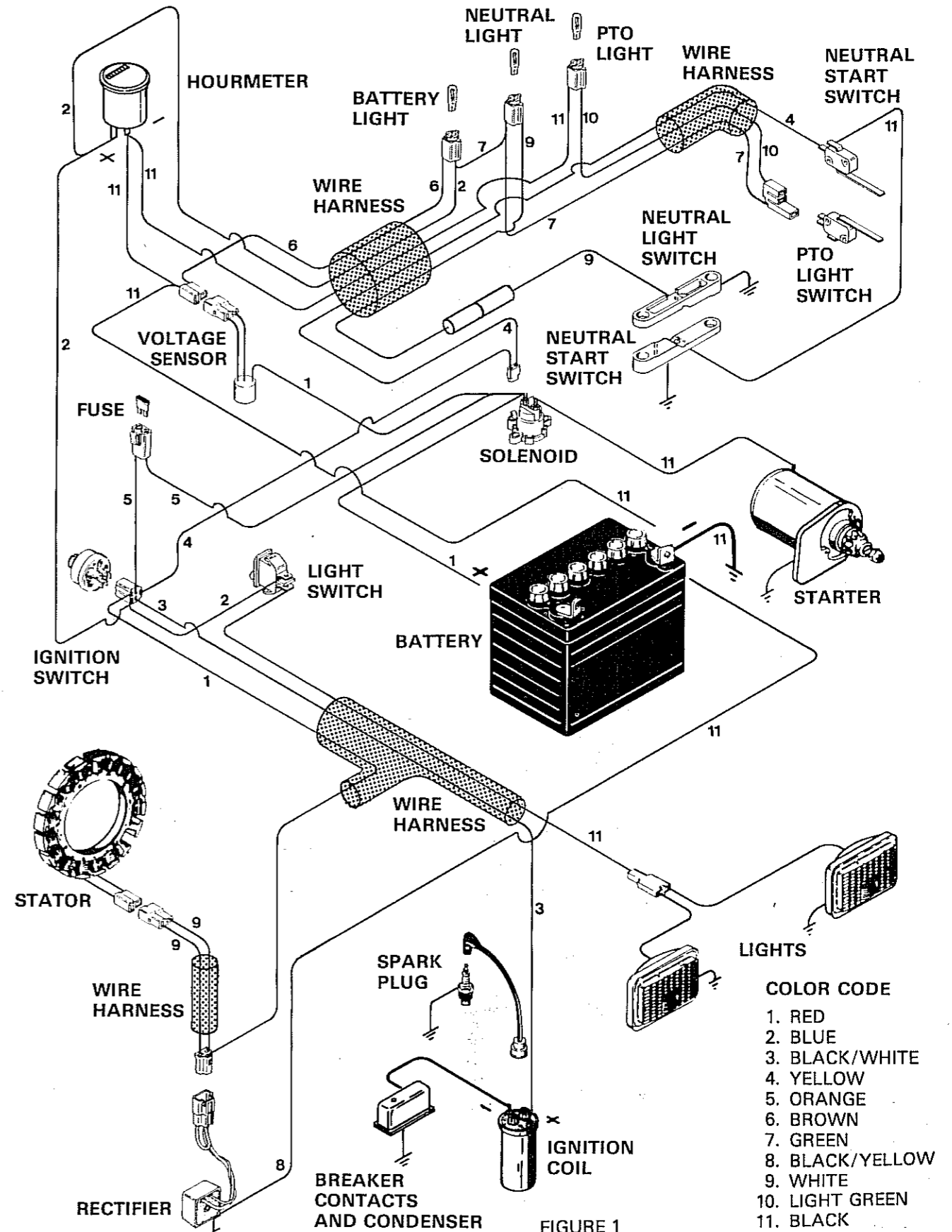

226-446-448 TRACTOR WIRING DIAGRAM

226 - PIN TO 14094020
 446 - PIN 9742953 TO 14096200
 448 - PIN TO 14097625

NOTE: Wire from "L" terminal on switch to lights can be pink.

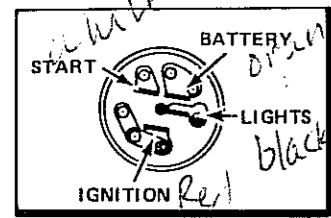

IGNITION SWITCH TERMINALS

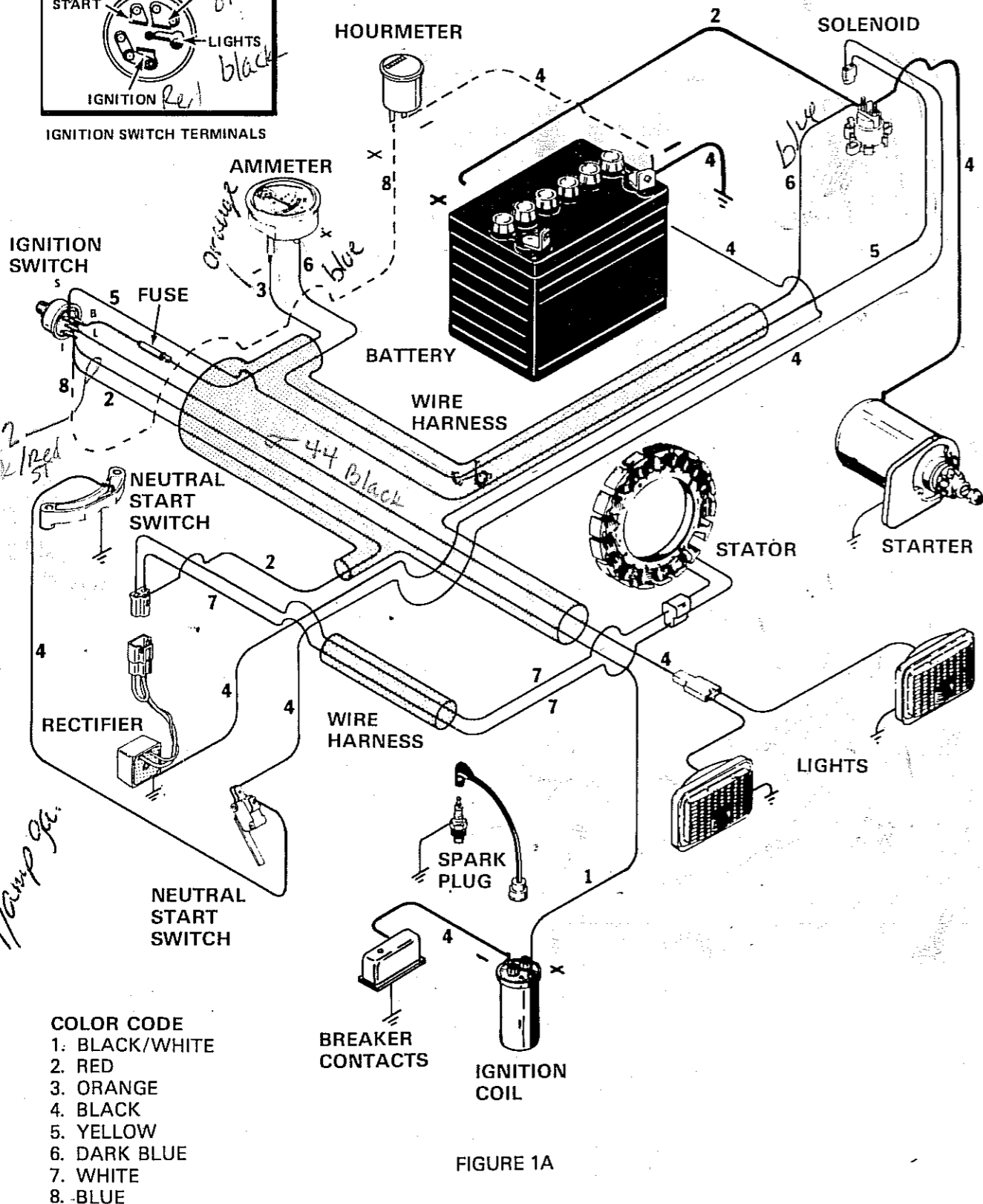

- COLOR CODE**
- 1. BLACK/WHITE
 - 2. RED
 - 3. ORANGE
 - 4. BLACK
 - 5. YELLOW
 - 6. DARK BLUE
 - 7. WHITE
 - 8. BLUE

FIGURE 1A

MODEL 446 WIRING DIAGRAM
 PRIOR TO PIN 9742953

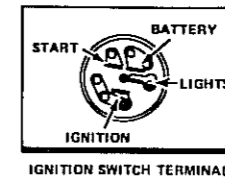

IGNITION SWITCH TERMINALS

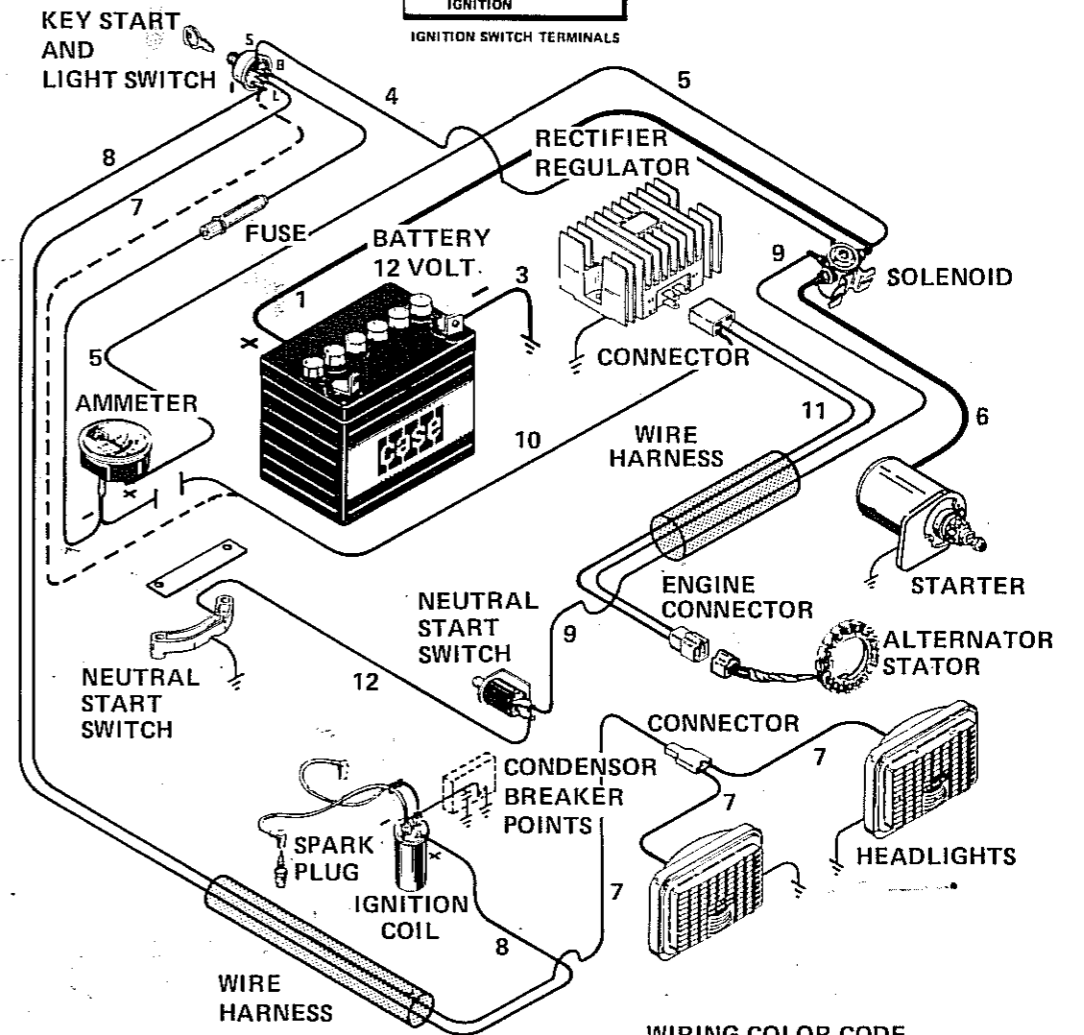

WIRING COLOR CODE

- 1. Red
- 2. Orange
- 3. Black
- 4. Yellow
- 5. Black
- 6. Black
- 7. Pink
- 8. Black/White
- 9. Black
- 10. Red
- 11. White

FIGURE 2

NOTE: To prevent battery drain while engine is stopped, remove red charging lead from ammeter "-" terminal and connect to key-switch "I" terminal.

MODEL 646 WIRING DIAGRAM
PIN 9732190 AND AFTER

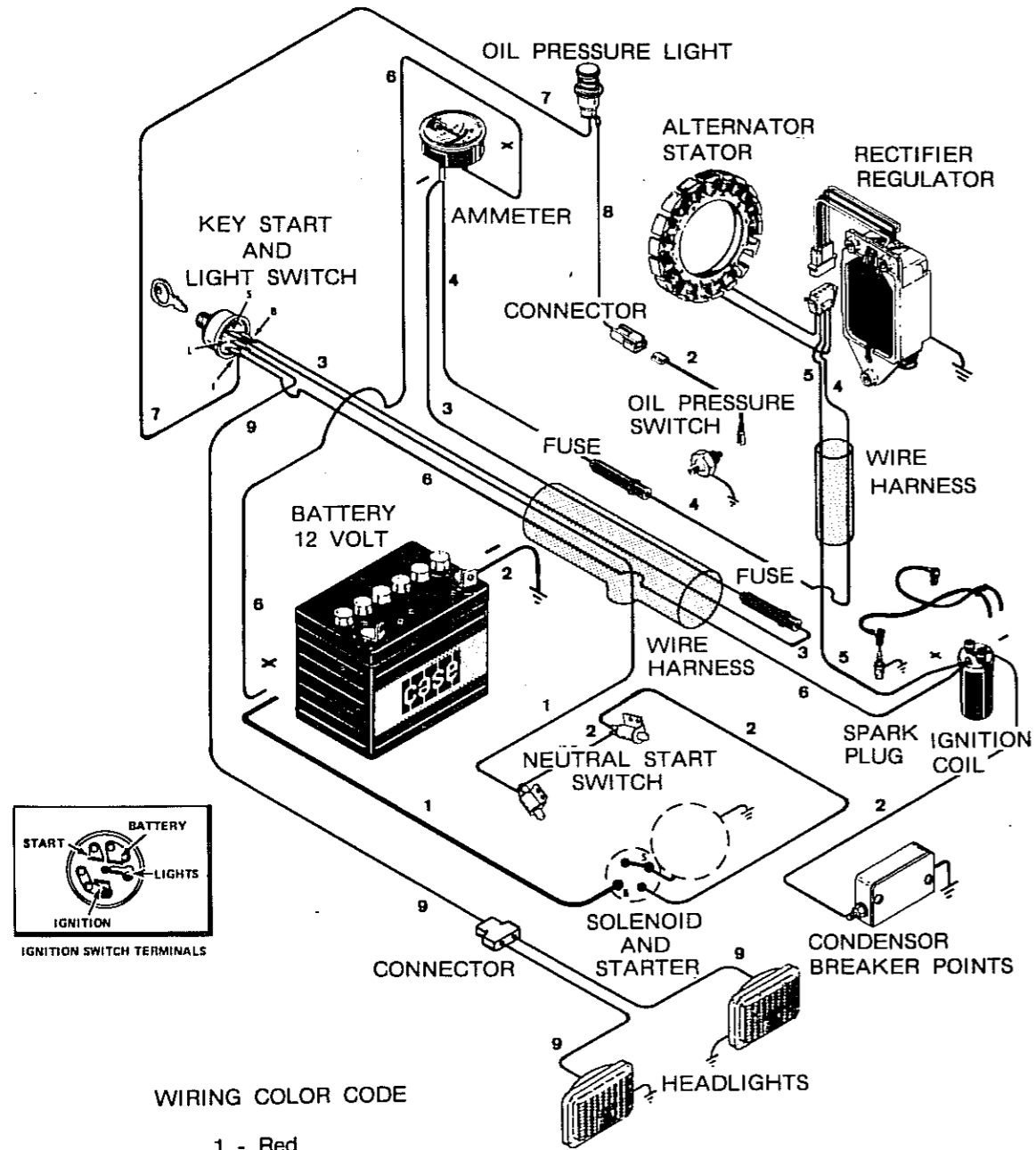

WIRING COLOR CODE

- 1 - Red
- 2 - Black
- 3 - Yellow
- 4 - Red/white
- 5 - Blue
- 6 - White
- 7 - Brown
- 8 - Black/white
- 9 - Pink

NOTE: Install C23744 neutral start switch kit for 646 loaders prior to PIN 9732190.

FIGURE 3

MODEL 648 WIRING DIAGRAM

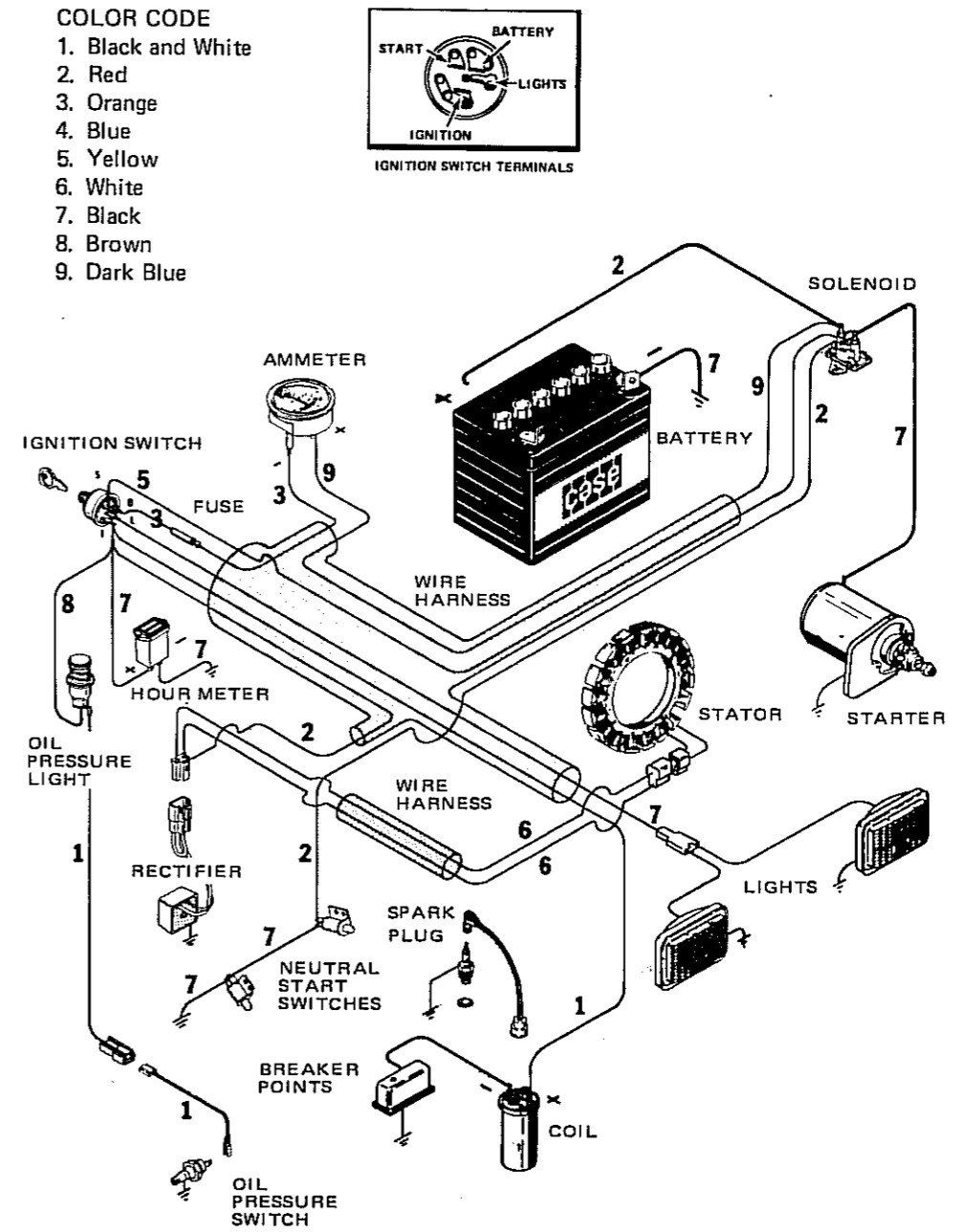

- COLOR CODE**
- 1. Black and White
 - 2. Red
 - 3. Orange
 - 4. Blue
 - 5. Yellow
 - 6. White
 - 7. Black
 - 8. Brown
 - 9. Dark Blue

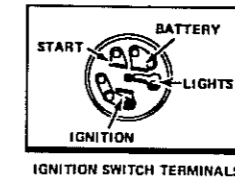
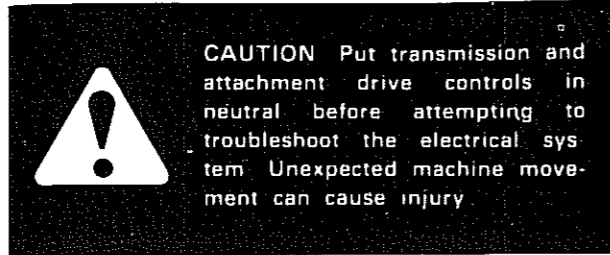

FIGURE 4

TROUBLESHOOTING CHART



I. ENGINE WILL NOT CRANK

SYMPTOM	POSSIBLE CAUSE	TEST	SOLUTION
A. Solenoid doesn't click or clicks repeatedly (See "B" below)	1. Dead or weak battery	Hydrometer test. Voltmeter reading 9.5 minimum at battery terminals when cranking	Charge or replace battery
	2. Poor or open connection at solenoid, ampmeter, fuse, key switch, or neutral start switches	Visually inspect	Clean and tighten loose or corroded connections
B. Solenoid doesn't click	1. One or both neutral start switches open	All models except 646 PIN 9732190 and after: Connect jumper wire from solenoid post (Small post ground side) to ground. Turn key to start. 646 PIN 9732190 and after: Briefly touch wire from battery "+" terminal to starter solenoid spade terminal.	Disengage PTO clutch and put travel lever in N. Repair or replace one or both N start switches if defective
	2. Fuse blown	Check continuity	Replace fuse
	3. Open ampmeter	Check continuity	Replace ampmeter
	4. Open solenoid	Check continuity	Replace solenoid
	5. Open ignition switch	Connect jumper from battery positive to solenoid "+" small terminal or from B to S terminal on switch	Replace ignition switch
C. Solenoid click but engine won't crank (See A above)	1. Engine tight	Attempt to turn engine manually to check for free rotation	Repair engine if found to be tight
	2. Defective solenoid switch	Connect heavy jumper wire across large solenoid posts. Engine should crank.	Replace solenoid
	3. Defective or worn starter		Repair or replace. See starter motor section of this manual.

II. ENGINE CRANKS IN GEAR

A. Engine cranks with travel lever in drive (600 series - travel pedal depressed)	Grounded N start switch (travel or PTO) or wire lead	Visual inspection. Disconnect wire from small solenoid post to PTO N-Start switch.*	Repair or replace wire lead or N - Start switch (travel or PTO).
B. Engine cranks with PTO clutch in gear or both travel and PTO in gear.	Grounded PTO N - Start switch or wire lead or grounded starter solenoid	Visual inspection. Disconnect wire from small solenoid posts N - Start switch. Attempt to crank engine.*	Repair or replace lead or N - Start switch. If unit cranks with wire disconnected - R & R solenoid.

*646 PIN 9732190 and after - cranking with travel pedal depressed or PTO "on" indicates misadjusted or shorted N-Start switches.

III. ENGINE CRANKS, BUT WON'T START

SYMPTOM	POSSIBLE CAUSE	TEST	SOLUTION
A. Engine cranks slowly and won't start (Electrical problems only)	See A. & C. above		
B. Engine cranks but won't start (No spark)	1. Points not opening and closing	Check gap	Clean and set gap. Time engine. Refer to specifications for correct point gap.
	2. No (low) voltage to coil	Check for battery voltage at coil + with voltmeter or testing light. Hold switch in "start" position. Check wire connections and ignition switch continuity from "B" to "I" in both start and run positions	Replace switch or wires as required. 646 prior to PIN 9732190: excessive voltage drops at starter solenoid. Install C23744 N-start switch.
	3. Spark plug	Inspect for grounded high tension lead or cracked insulator or fouled spark plug	Repair or replace lead or plug as required
	4. Defective ignition coil	Use coil tester	Replace
	5. Shorted to ground condenser	Unhook condenser lead. Crank engine. If weak spark is now seen, condenser was shorted.	Replace condenser

IV. ENGINE RUNS ERRATICALLY

A. Engine runs at idle and erratically (electrical problems only). Flashing blue arc at points. Points burned.	Faulty condenser or condenser connected to coil "+" (points and condenser should be connected to coil "-")	Condenser test. Inspect connection.	Replace or connect condenser to coil "-".
----------------------------------------------------------------------------------------------------------------	------------------------------------------------------------------------------------------------------------	-------------------------------------	-------------------------------------------

V. BATTERY UNDER CHARGING (OR NO CHARGE)

A. Battery goes dead with normal usage	1. Defective battery	Recharge and perform battery test	Replace if necessary
	2. Cold weather, short running periods	Recharge and perform battery test	Use battery heater and trickle charger
	3. Stop start operation	Recharge and perform battery test	Keep engine speed high enough to charge
	4. Dirty or corroded terminals or wires	Visual inspection	Clean
	5. Excessive electrical loads	Total individual loads	Reduce total load
B. No charge to battery (ampmeter at .0)	Battery fully charged	Turn head lights on for 5 minutes with engine shut off. Start tractor.	Ampmeter shows charge. Indicates charging system functioning properly.
	Defective rectifier, regulator or stator.	Run engine at 3600 RPM for 3 - 5 minutes. Measure D-C volts at battery terminal	If 13.6 volts charging system okay, check for faulty ampmeter or fully charged battery. If less than 13.6 volts, test stator output.
		Run engine at 3600 RPM. Measure AC volts at stator output plug* (unplug from rectifier regulator)	If less than 28 VAC replace stator. Retest rectifier regulator. If more than 28 VAC, stator okay, replace rectifier regulator.

*NOTE: Be sure to check all connections for continuity before replacing major components. Be sure rectifier regulator is grounded to tractor frame.

†NOTE: Stator output voltage between 14 and 28 volts AC is adequate to charge battery at reduced rate. Reduced stator output could be caused by dirt accumulations or weak flywheel magnets. Remove flywheel, inspect and correct as necessary.

VI. BATTERY CONTINUOUSLY CHARGES AT HIGH RATE

SYMPTOM	POSSIBLE CAUSE	TEST	SOLUTION
A. Ammeter continuously shows high value. Water consumption exceeds 1 oz each 25 hours.	Rectifier-regulator over-charging or defective battery	Run engine at 3600 RPM for 3-5 minutes. Measure DC volts at battery terminal.	If more than 14.7 volts, replace rectifier-regulator. If less than 14.7 volts, battery unable to hold charge. Test battery, replace if necessary.

VII. ACCESSORIES

A. Oil pressure light does not glow when key is turned on (646, 648 only)	1. Open sender switch	1. Remove wire from sender - touch to ground. Light should glow when key is on	1. If light glows, replace sender.
	2. Open wire or connections	2. Check continuity	2. Tighten connections, replace broken wires.
	3. Bulb burned out	3. Check continuity	3. Replace bulb.
B. Hour meter does not operate (648 only)	1. Open wire or connections	1. Check for battery voltage at meter "+" terminal with key on and for ground connection	1. Replace wires. Tighten connections.
	2. Open meter	2. Check continuity	2. Replace meter.

ACTIVATING THE DRY-CHARGED BATTERY

The activation procedure described below must be followed to insure satisfactory battery performance.

1. Remove battery from tractor. This must be done to prevent accidental spillage of battery acid on metal tractor parts.
2. Remove battery caps and fill to a point slightly BELOW the vent well. Small battery size may cause electrolyte to bubble over when charging if filled to vent well at first.
3. Charge at 3 amp rate until fully charged (1.260 specific gravity). Higher charging rates may damage battery. See the Battery Maintenance section of this manual.
4. Disconnect charger. Unplug charger from wall before disconnecting at battery to prevent spark at battery post.
5. Top off each cell with electrolyte to the vent well if required. Install battery caps.
6. Wash battery with baking soda solution if moist from electrolyte. Be careful not to get baking soda solution in cells.
7. Install battery in tractor. Connect positive cable first and negative cable last. Coat terminals with cup grease to prevent corrosion.



CAUTION: When removing a battery always disconnect the negative (ground) cable first. When installing the battery always connect the negative (ground) cable last. This will prevent accidental grounding of wrench when disconnecting or connecting the positive cable. Place all electrical switches in the 'off' position.

8. Maintain battery as described in the Battery Maintenance section of this manual.

REMOVAL AND INSTALLATION

Proper removal and installation procedures are required to prevent personal injury and damage to battery or equipment.

1. Place all electrical switches in the "off" position.
2. To remove battery: DISCONNECT NEGATIVE ("-") cable first and POSITIVE ("+") cable last.
3. To install battery: CONNECT POSITIVE ("+") cable first and NEGATIVE ("-") cable last.
4. Be sure to install insulating boot when provided, on POSITIVE ("+") terminal.
5. Use care when tightening or loosening cables at battery terminals. Excessive force or hammering will cause damage to battery.
6. Coat battery terminals with light cup grease to prevent corrosion.
7. Tighten battery hold down securely. Avoid overtightening which could cause damage to battery case or cells.

BATTERY MAINTENANCE

1. BATTERY TOP: The battery top must be kept clean and dry. Dirt or moisture will cause the battery to self-discharge. The battery top can be cleaned with baking soda solution. Do not allow baking soda solution to enter the cells.
2. TERMINAL CONNECTIONS: The battery terminal connections must be kept clean and tight. Loose or corroded connections offer resistance to current flow resulting in poor battery performance.

Use a wire brush to clean terminals and coat with cup grease to prevent corrosion.



CAUTION: When working around storage batteries remember that all exposed metal parts are "live". Never lay a metal object across the terminals as a spark or short circuit may result.

3. **ELECTROLYTE LEVEL:** The electrolyte level must be maintained above the cell plates at all times to avoid permanent battery damage. The battery must be kept filled to the vent well with water free of scale forming minerals.

Water consumption in excess of 1 ounce (29 ml) every 25 hours of operation indicates an over-charging problem. See the testing section of this manual.

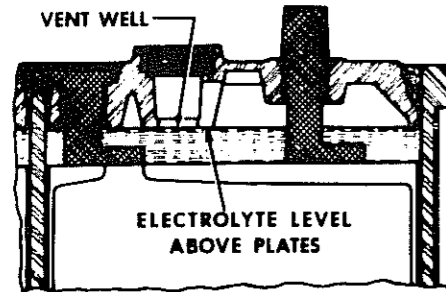

FIGURE 5

4. **STATE OF CHARGE:** The battery must be maintained in a full state of charge as indicated by hydrometer readings. A battery that is allowed to stand in a discharged condition will become permanently damaged.

An idle battery will self discharge. For this reason, idle batteries should be checked periodically and charged as necessary.

Discharged batteries will freeze in cold weather. For example, a battery with specific gravity of 1.175 will freeze at 0°F (-18°C).

5. **CHARGING PROCEDURE:**

A. Charging at a rate not to exceed 3 amps is recommended.

B. Charging at higher rates up to 15 amps is permissible as long as:

- a. Violent gassing does not occur
- b. Electrolyte is not spewed from vents
- c. Electrolyte temperature does not exceed 125°F (51°C)

DO NOT exceed 15 amps charge rate.

C. A battery is fully charged when, after two, two hour intervals at a low charge rate (3 amps), all cells are gassing freely and no change in specific gravity occurs.

D. Always turn charger off or unplug from wall before removing clips from battery terminals. This prevents arcing at battery which can cause explosion of hydrogen gas created while charging.

BATTERY TESTING

SPECIFIC GRAVITY TEST (HYDROMETER TEST): The hydrometer is used to measure the specific gravity of battery electrolyte (weight of electrolyte as compared to water). This indicates the state of charge of the battery.

Mix newly added water with electrolyte before taking hydrometer readings by:

- a. charging for 15 minutes at 3 amps and
- b. applying a 75 amp load for 15 seconds (about equal to cranking engine for 15 seconds).

The hydrometer reading is only correct when electrolyte temperature is 80°F (25°C). Correct readings for temperature variation in accordance with the following guidelines:

Electrolyte temperature correction - Fahrenheit scale

For every 10°F below 80°F SUBTRACT .004 from the observed hydrometer reading.

For every 10°F above 80°F ADD .004 to the observed hydrometer reading.

Electrolyte temperature correction - Celsius scale

For every 10°C below 25°C SUBTRACT .007 from the observed hydrometer reading.

For every 10°C above 25°C ADD .007 to the observed hydrometer reading.

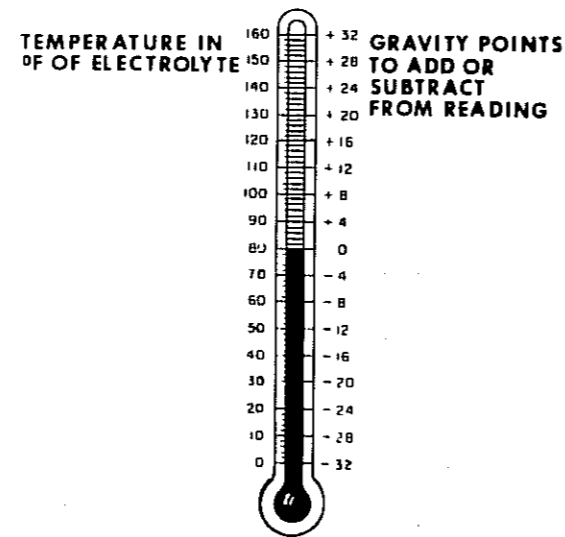

FIGURE 6

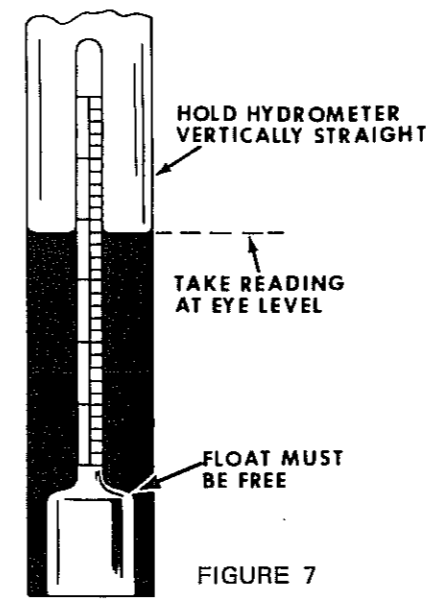

FIGURE 7

Fill hydrometer with enough electrolyte to allow float to float freely. Hold hydrometer vertically and at eye level when taking a reading. Record reading for each cell, and correct for temperature as described above. Refer to battery check sheet.

LOAD TEST: Perform the battery load test by loading the battery to 3 times its amp-hour rating for 15 seconds.

- Examples: 3 x 24 amp-hour = 72 amp load
- 3 x 32 amp-hour = 96 amp load

This load can be created with a battery load tester or by cranking the engine (cranking load of room temperature engine is approximately 80 amps).

Follow the step-chart and enter results on the battery check sheet.

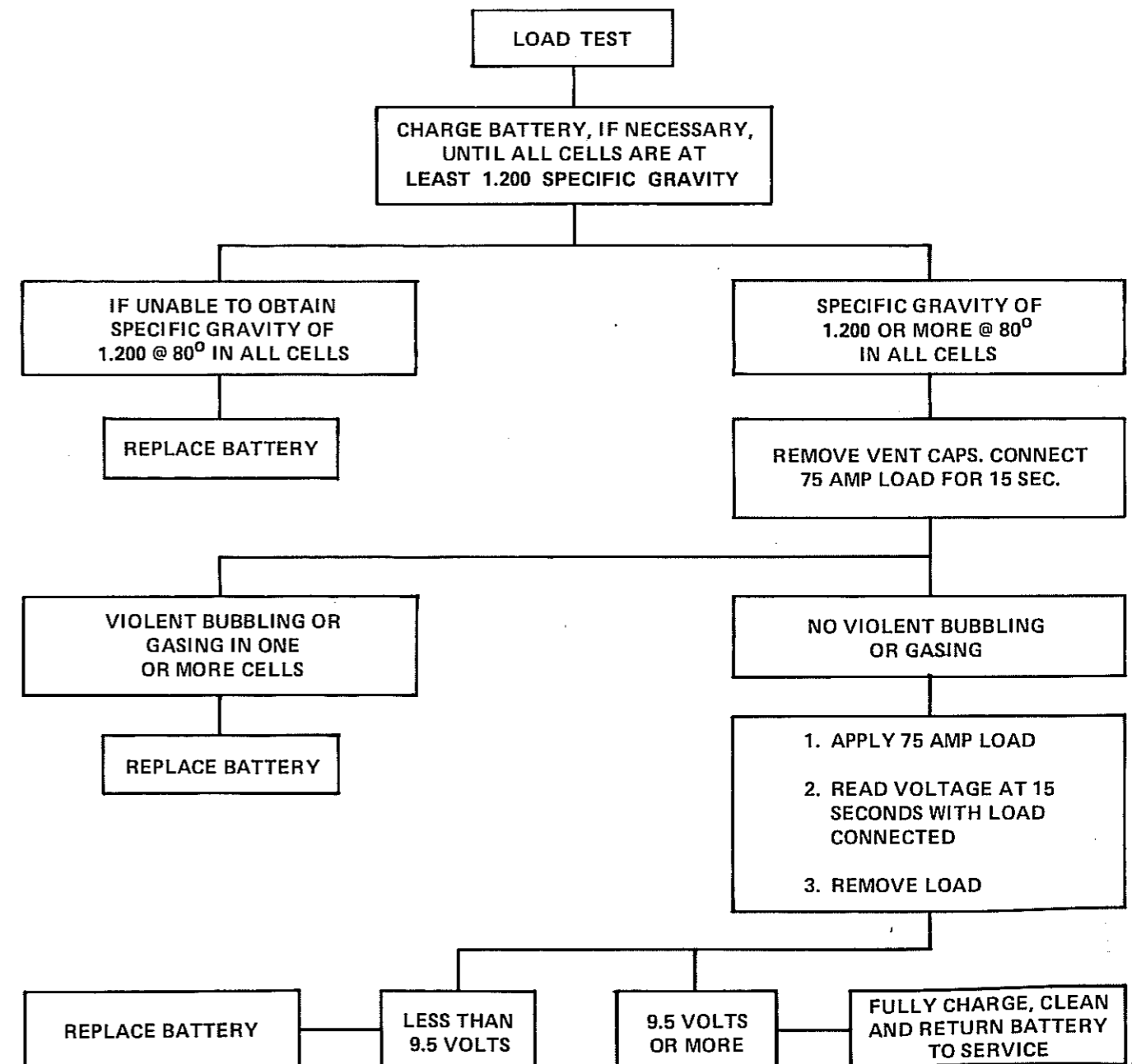

TEST Result	Summary	Indication	Remedy
VISUAL INSPECTION			
1. Dirty battery top _____		Battery OK	Clean
2. Clogged vents _____		Battery OK	Clean
3. Corrosion _____		If severe, possible battery defect.	Clean and continue testing.
4. Low water level _____	Excess water use - Test for overcharging.	Battery OK	Add water
5. Cracked case _____		Defective battery	Replace

SPECIFIC GRAVITY CHECK

Cell No. 1 _____	1. More than 30 gravity points variation between cells.	1. Defective, discharged or worn out battery.	1. Recharge battery. Repeat test. If cell readings still vary more than 30 points, replace battery.
Cell No. 2 _____			
Cell No. 3 _____	2. Most cells below 1.230 and within 30 points.	2. Discharged	2. Recharge and make Load Test.
Cell No. 4 _____			
Cell No. 5 _____	3. Most cells at or near full charge (1.260) and within 30 points.	3. Charged	3. Make Load Test.
Cell No. 6 _____			
	4. Most cells above full charge (1.260)	4. Overcharged	4. Check regulator.

NOTE: Specific gravity readings apply to original equipment or Case supplied replacement batteries only. Other makes may vary.

LOAD TEST

Battery must have 1.200 specific gravity. Load equals 20-hour amp rating x 3 for 15 seconds			
12 volt battery _____	Over 9.5 volts	Battery OK	Recharge if necessary
	Under 9.5 volts	Defective	Replace

Starter motor repairs may be made if troubleshooting procedures described in this manual reveal an internal starter problem.

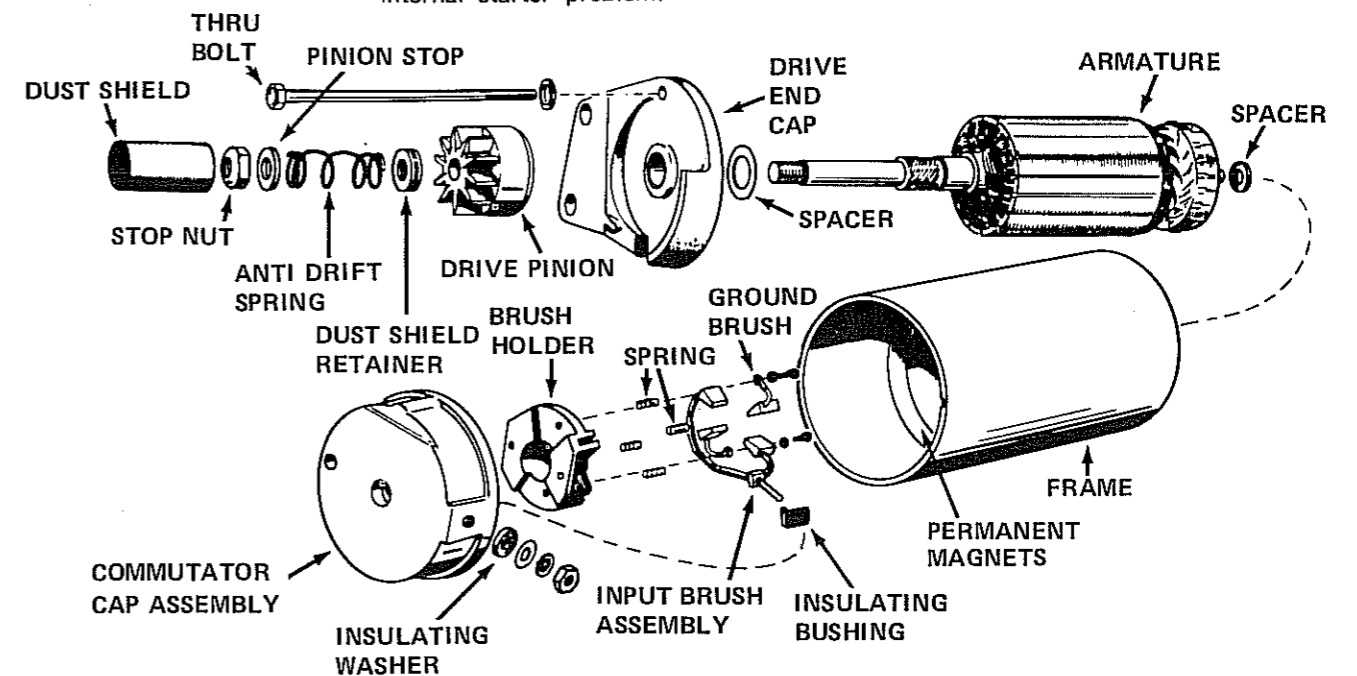

FIGURE 8

BRUSH - COMMUTATOR SERVICE

The starter must be completely disassembled to service brushes and commutator. Proceed as follows:

1. Remove the thru bolts.
2. Separate the end cap from armature.

NOTE: Brush springs will probably fall out when brushes pull free of the commutator.

3. Clean the commutator with a coarse, lint-free cloth. If the commutator is badly worn or grooved, turn it down on a lathe.

4. The input brushes are part of the terminal stud assembly. Use the following procedure to replace the input brushes:

- (a) Remove the nuts
- (b) Pull the stud out through the inside of the end cap
- (c) Transfer the insulation bushing from the old unit

- (d) Insert the new stud, brushes and springs. Use the following procedure to replace the insulated brushes:

Remove the capscrews and lock washers

Remove the old brushes

Install the new brushes and springs

Assemble the brushes with the chamfered side away from the springs. Do not let the brush wires contact the metal end cap.

5. Use a brush holder tool (Fig. 9) to keep the brushes in position as the end cap is being installed. This tool can be made from thin sheet metal.

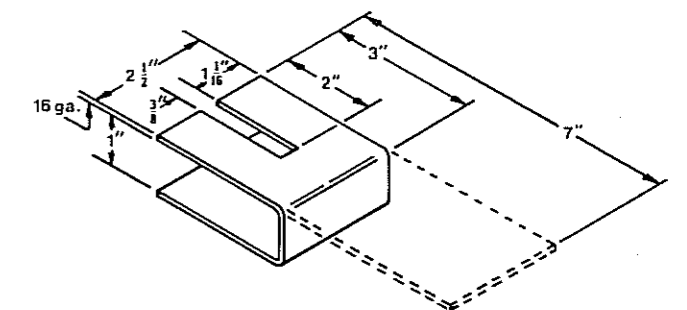

FIGURE 9 Brush Holder Tool

DRIVE ASSEMBLY

Replace drive assembly if pinion is badly worn or has broken teeth.

To remove drive assembly:

1. Hold armature shaft.
2. Remove dust shield, stop nut, pinion stop, anti drift spring, and dust shield retainer.
3. Slip drive pinion off over spline and armature shaft.

Leave drive off if further disassembly of starter is required.

To install drive assembly:

1. Thoroughly clean the drive shaft and pinion and apply a small amount of lubriplate AERO grease or other dry lubricant such as graphite.
2. Install drive pinion, dust shield retainer, anti drift spring, pinion stop.
3. Apply Loctite # 271 to threads. Tighten stop nut to 20-25 lb. ft. (27-34 Nm). Wipe excess Loctite from threads.
4. Push dust shield on until it snaps into position over the shield retainer.

INSPECTION OF PARTS

TESTING ARMATURE FOR GROUNDS

Touch armature shaft or core and the end of each commutator bar with a pair of ohmmeter leads. If the ohmmeter reading is low, it indicates a grounded armature. Replace grounded armature.

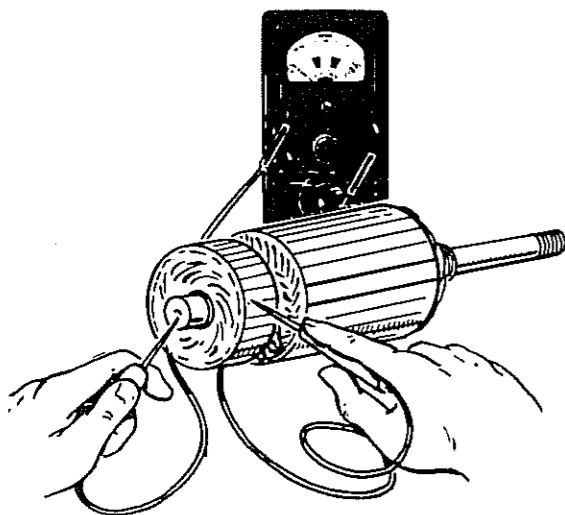

FIGURE 10 Testing Armature For Grounds

TESTING ARMATURE FOR A SHORT CIRCUIT

Use a growler for locating shorts in the armature. Put armature in growler. Hold a thin steel blade (e.g. hacksaw blade) parallel to the core and just above it. Slowly rotate armature in growler. A shorted armature will cause the blade to vibrate and be attracted to the core. Replace shorted armature.

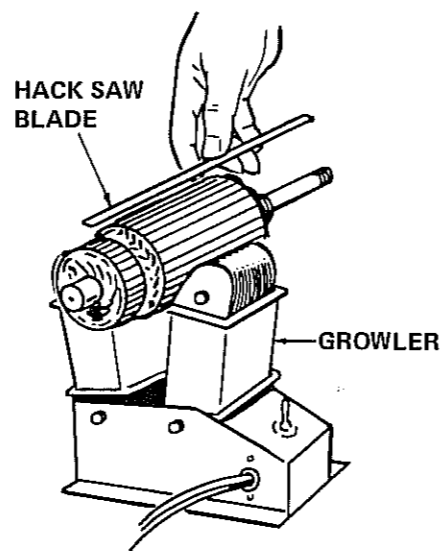

FIGURE 11 Testing Armature For Short Circuits

INSPECTING FOR AN OPEN CIRCUIT IN ARMATURE

The most likely place to check for an open circuit is at the commutator riser bars. Inspect for loose connections on the points where the conductors are joined to the commutator bars.

BRUSH INSPECTION

If brushes are worn shorter than 1/4 inch (6.35 mm), replace them. Check to see that brushes move smoothly in the brush holders.

STARTER FASTENER TORQUE SPECIFICATIONS

Bolts for insulated brushes ...3-3½ lb. ft. (4-5 Nm)
Terminal stud nut4-5 lb. ft. (5-7 Nm)
Drive stop nut20-25 lb. ft. (27-34 Nm)
Through-bolts4½-6 lb. ft. (6-8 Nm)

STARTER REMOVAL

1. Remove the necessary tractor sheet metal and accessories to enable the engine blower housing to be removed.

2. Remove the engine blower housing.

3. Remove the starter wire.

4. Remove the starter mounting bolts.

0.020 ± 0.010" (0.51 ± 0.25 mm)
FLYWHEEL GEAR FREE TRAVEL WHEN
ENGAGED WITH STARTER GEAR

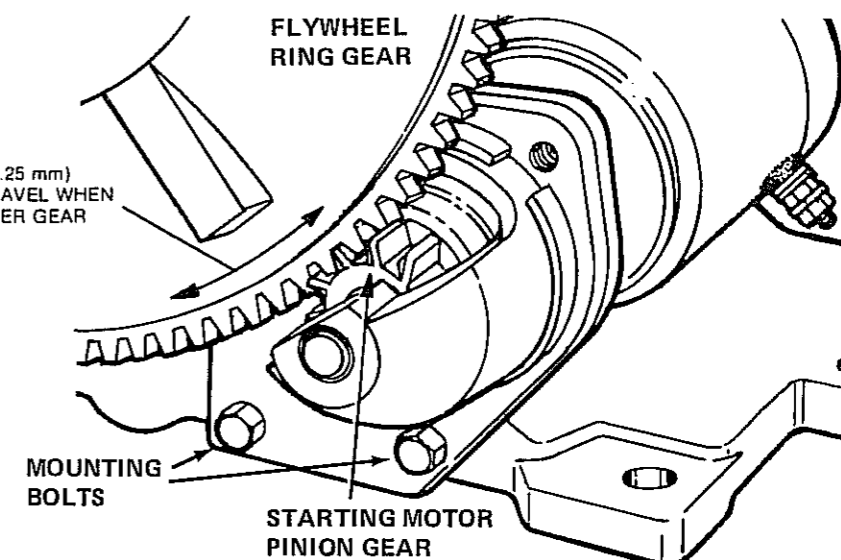

FIGURE 12 Checking Starter Gear Lash

STARTER INSTALLATION

1. Clean dirt and oil from the starter mounting surface on both the starter and engine.
2. Install the starter motor and tighten the mounting bolts just enough to hold the starter in its place.
3. Pull the starter pinion gear outward on its shaft so that its teeth mesh fully with those on the flywheel.

4. Measure the amount of free travel, or lash, between the pinion gear teeth and the ring gear teeth, as shown in Figure 12. The proper lash is 0.020 ± 0.010 (0.51 ± 0.25 mm). Loosen and adjust the starter motor as necessary to obtain the correct setting.

5. Tighten the starter mounting bolts.

6. Connect the wire to the terminal on the starter motor.

7. Install blower housing and tractor accessories and sheet metal.

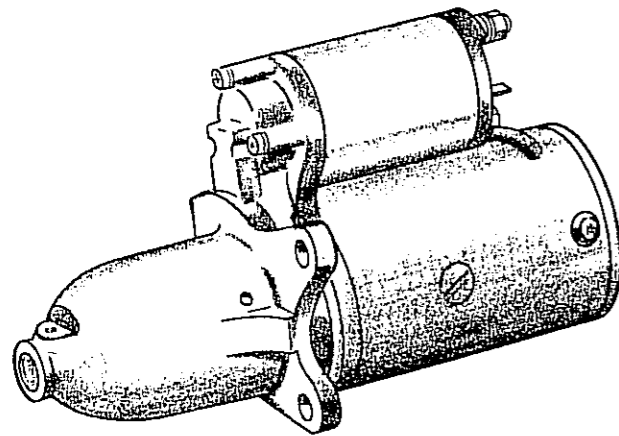

FIGURE 13 Starter Assembly

STARTER DISASSEMBLY

1. Loosen the M terminal nut on the magnetic switch and remove the connector. Remove the magnetic switch.

NOTE: The packings for the magnetic switch are mounted so that the steel packing is located in the front bracket side.

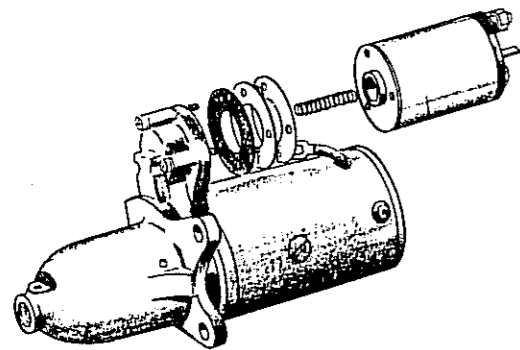

FIGURE 14 Magnetic Switch Removal

2. After removing the thru bolts, the starting motor can be divided into three parts — the front bracket, housing and rear bracket.

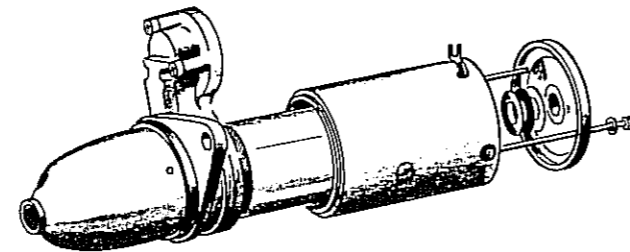

FIGURE 15 Removing Through Bolts

3. Remove the armature from the front bracket. Be careful not to miss a small steel washer used in the end of the armature shaft. Remove the shift lever along with the armature. In this case, the spring holder, lever springs and retainer can be taken out before the lever.

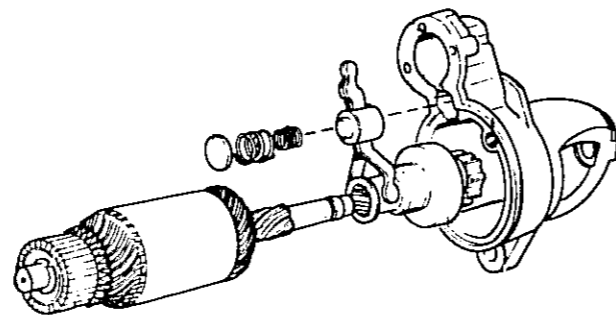

FIGURE 16 Removing Armature

The spacing washers shown in Figure 15 are used for adjustment of the thrust gap of the armature shaft. They are between the rear bracket and the commutator.

NOTE: These washers are inserted so the steel washer is located in the commutator side.

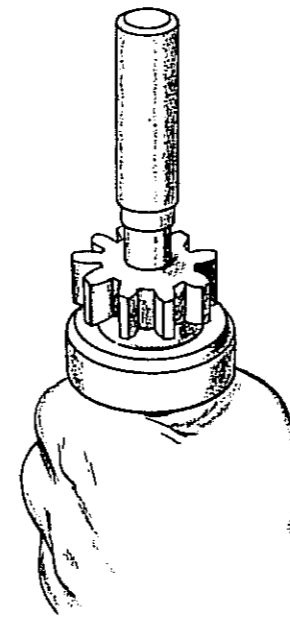

FIGURE 17 Removing Ring

4. Remove the ring after driving the pinion stopper toward the pinion gear using a cylindrical tool as shown in Figure 17. The overrunning clutch and the pinion stopper should be removed simultaneously.

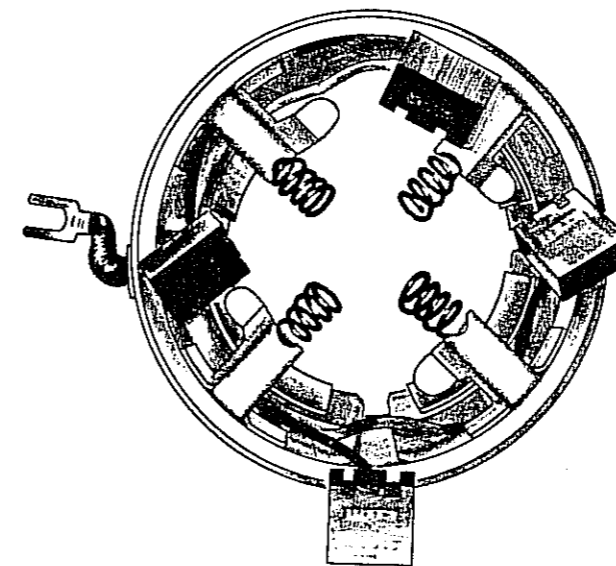

FIGURE 18 Brushes

5. All four brushes have been soldered to the brushholder in the same way. The brush springs can be removed from the brushholder.
6. The pole shoes may be removed if necessary, by removing the flat head machine screws from the frame.

STARTER REASSEMBLY

Inspect the parts carefully in accordance with the procedure described in "Inspection of Parts". Make any repairs necessary. Reassembly is the reverse of Disassembly. The following precautions should be taken:

1. Clean all of the parts carefully with a dry cloth and compressed air.

IMPORTANT: Do not use steam or high pressure water to clean the starter.

NOTE: (A) Bearing equipped parts must not be immersed in cleaning fluid. These parts should be cleaned with a brush dipped in "Varsol" or any other comparable mineral spirits.

(b) Do not immerse overrunning clutch in cleaning solvent.

(c) Thoroughly dry any parts that have come into contact with the cleaning fluid.

2. Apply SAE 20 oil to the armature shaft and splines. Apply grease (Shell Albania No. 2 or equivalent) sparingly on the shift lever pin, the joint of the shift lever and plunger, the plunger and spacing washers at the end of the shaft.

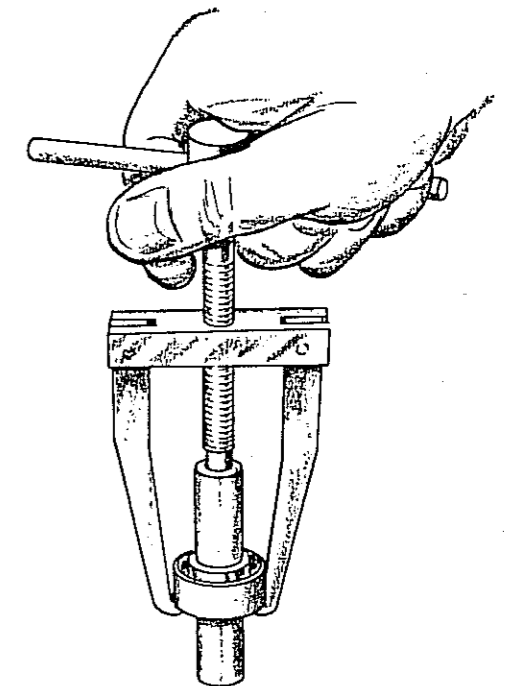

FIGURE 19 Mounting Overrunning Clutch

3. To mount the overrunning clutch:

- a. Insert the pinion stopper into the armature shaft.
- b. Apply the ring to the groove of the shaft. Use a tool as shown in Figure 19 and pull the pinion stopper up.

4. Use spacing washers to adjust the armature to give end play of .004" to .020" (0.10 to 0.5 mm).

5. Tighten the thru bolts to a torque of 35 to 44 in.-lbs. (4 to 5 Nm).

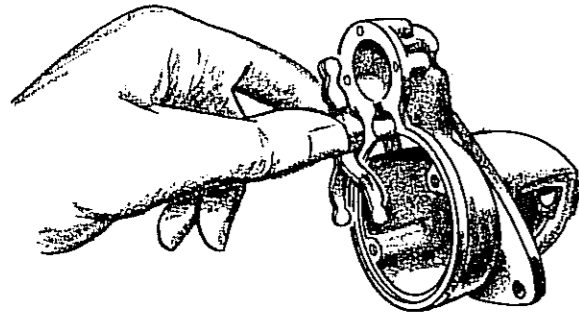

FIGURE 20 Installing Shift Lever

INSPECTION OF PARTS

TESTING ARMATURE FOR SHORT CIRCUITS

Put the armature in a growler. Hold a thin steel blade parallel to the core and just above it. Slowly rotating the armature in the growler. A shorted armature will cause the blade to vibrate and be attracted to the core. Replace shorted armature.

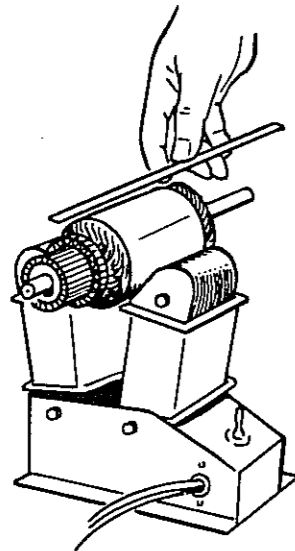

FIGURE 21 Testing Armature For Short Circuits

TESTING ARMATURE FOR GROUNDS

Touch armature shaft or core and the end of each commutator bar with a pair of ohmmeter leads. If the ohmmeter reading is low, it indicates a grounded armature. Replace grounded armature.

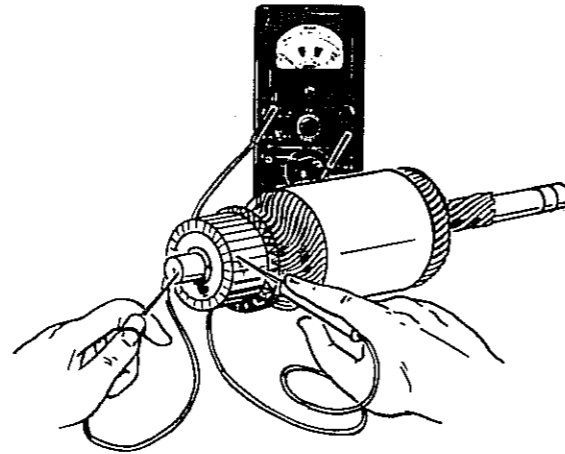

FIGURE 22 Testing Armature For Grounds

TESTING ARMATURE FOR OPEN CIRCUITS

The most likely place for an open to occur is at the commutator riser bars. Inspect the points where the conductors are joined to the commutator bars for loose connections.

TESTING COMMUTATOR RUNOUT

Put armature in a test bench and check runout with a dial indicator. When commutator runout exceeds .004", (0.10 mm) commutator should be re-faced.

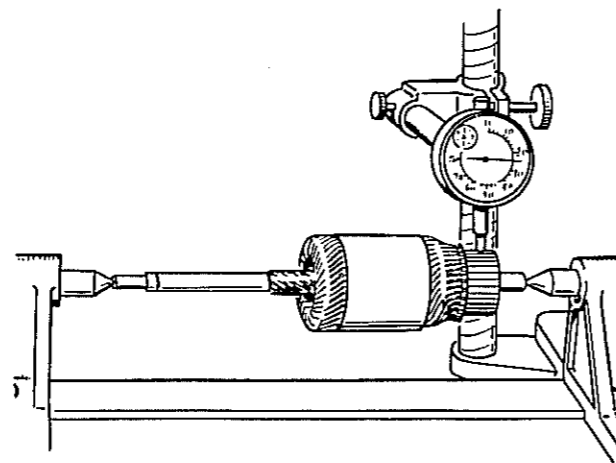

FIGURE 23 Testing Commutator Runout

TESTING ARMATURE SHAFT RUNOUT

The armature shaft as well as the commutator may be checked. A bent armature often may be straightened, but if the shaft is worn, a new armature is required.

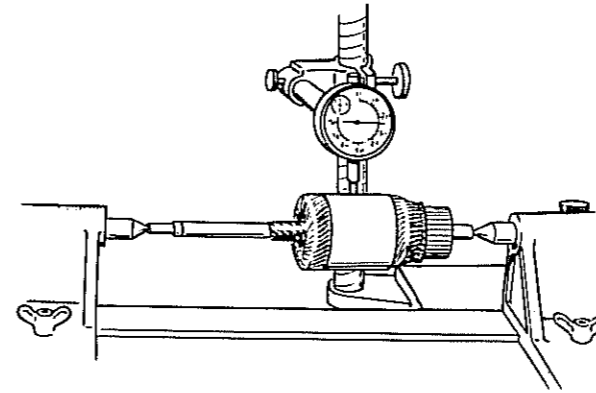

FIGURE 24 Testing Armature Runout

TESTING FIELD COILS FOR GROUNDS

Put one lead on the connector and the other on a clean spot on the frame after unsoldering shunt field coil wire. If the ohmmeter reading is low, the fields are grounded, either at the connector or in the windings.

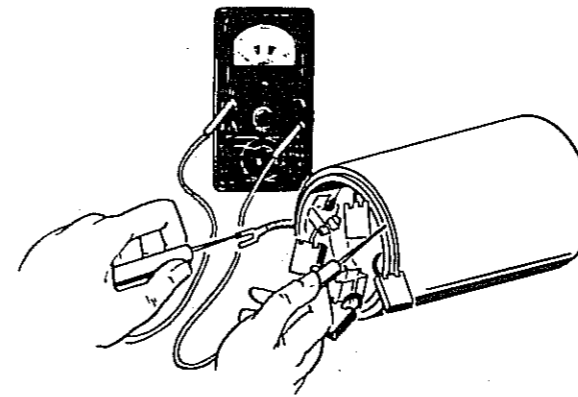

FIGURE 25 Testing Field Coils For Grounds

TESTING FIELD COILS FOR OPEN CIRCUIT

Put one lead on the connector and the other on a clean spot on the brushholder. If the ohmmeter reading is high, the field coil is open. Check the other three brushholders in the same manner.

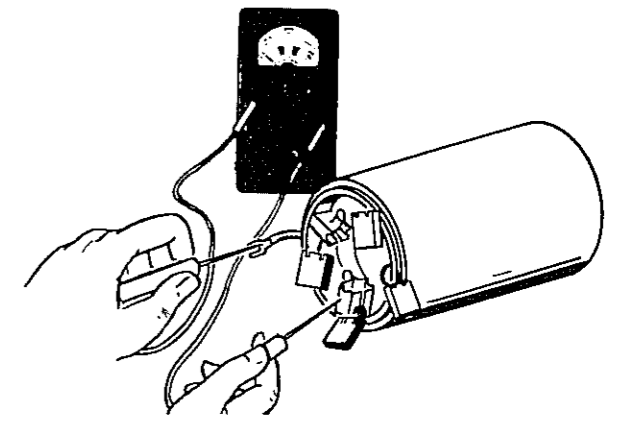

FIGURE 26 Testing Field Coils For Opens

INSPECTION OF BRUSHES

When brushes are worn more than .3" (7.6 mm) they are to be replaced. See that the brushes move smoothly in the brushholders.

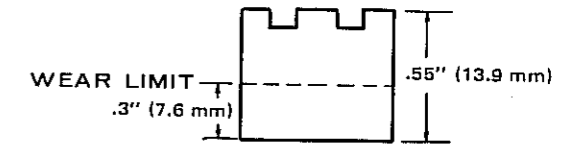

FIGURE 27 Brush Wear Limit

INSPECTION FOR BRUSH SPRING TENSION

Measure brush spring tension with a tension meter as shown. Push the brush and take a reading just as the brush projects a little from the brushholder. On a new brush the spring tension should be 29 to 38 ounces (8 to 10 N).

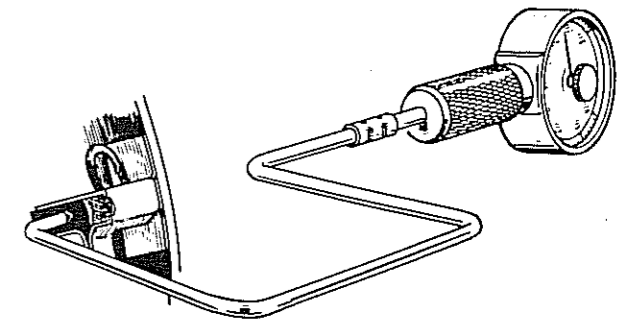

FIGURE 28 Testing Brush Spring Tension

INSPECTION AFTER OVERHAUL

1. For no load test, the starting motor is wired as shown and run. The meter reading should be as follows:

Voltage	11.5 Volt
RPM	3700
Current Draw	60 A Max.

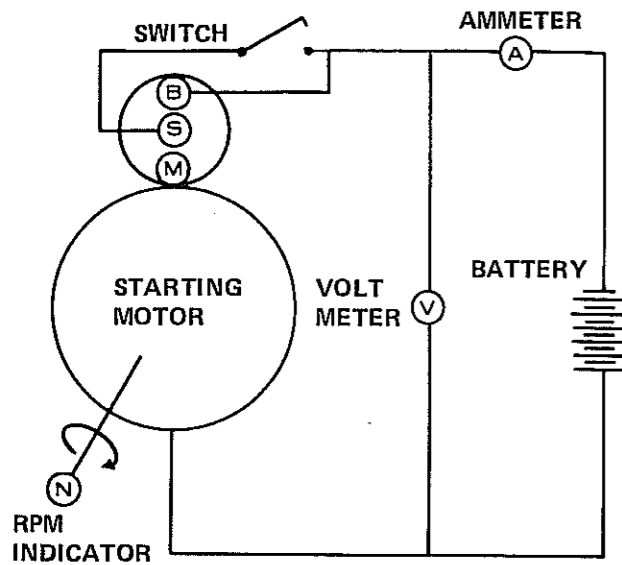

FIGURE 29 Starter Motor Wiring

NOTE: The conductor for this test should be large and as short as possible.

If anything is wrong in the previous test, inspect for the following problems:

- Annealed brush springs
- Improperly seated brushes
- Insufficient armature endplay
- Shorted, open or grounded armature
- Grounded or open field coil
- Poor electrical connection
- Dirty commutator

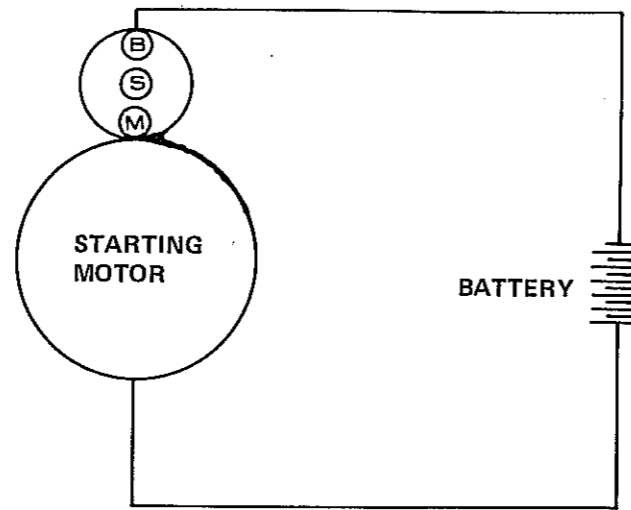

FIGURE 30 Battery Connections

2. To adjust pinion clearance, connect the battery to the starting motor as shown. This will allow the pinion of the starting motor to slide and stop. In this state, measure the clearance between the end of the pinion and pinion stop when the pinion is pushed lightly toward the commutator end. Clearance should be .02" to .06" (0.5 to 1.5 mm). Adjust for proper clearance by removing the magnetic switch attaching screws and select the proper thickness of the fiber packings shown in Figure 31.

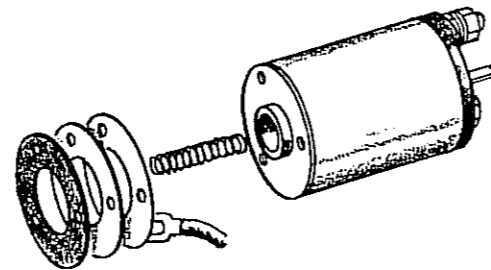

FIGURE 31 Adjusting Pinion Clearance

FLYWHEEL ALTERNATOR

Model 226, 446, 448 and 648 tractors are equipped with the Phelon 15 amp permanent magnet flywheel alternator and solid state voltage rectifier-regulator.

Model 646 tractors are equipped with the Wico 20 amp permanent magnet flywheel alternator and solid state voltage rectifier-regulator.

STATOR ASSEMBLY REPAIR

Test the stator output in accordance with charging system troubleshooting section of this manual. Be sure to check for continuity at terminal connections.

If A.C. output is more than zero but less than 28 volts, remove flywheel and inspect for dirt accumulation or weak magnets.

Flywheel magnet strength can be tested by loosely holding an unmagnetized screwdriver parallel with each magnet. The screwdriver should be drawn in contact with magnets from a distance of one inch (25 mm).

If the magnet ring is bolted to the flywheel, tighten the bolts to a torque of 60-80 in. lb. (7-9 Nm).

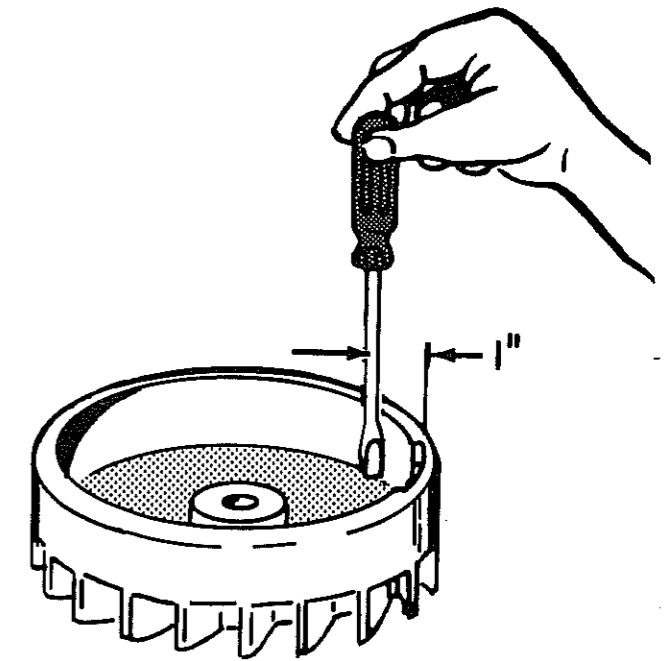

FIGURE 32 Testing Magnet Strength

IGNITION

NOTE: See Troubleshooting Section of this manual for troubleshooting information.

BREAKER POINT SERVICE

Engine operation is greatly affected by breaker point condition and adjustment of the gap. If points are burned or badly oxidized, little or no current will pass and as a result the engine may not operate at all, or if it does run it is likely to misfire, particularly at full throttle.

The breaker point gap affects the time that the contacts are opened and closed. If the points are adjusted to a wider gap, they will open earlier and close later. A definite time is required for the magnetic field within the ignition coil to build up to sufficient value. If the contact points are closed for too short a time, a weak spark will be produced by the coil. If points are set too wide, they will open before the primary current reaches the maximum value and on the other hand if set too close, they will open after the primary current has passed its maximum value.

BREAKER POINT REPLACEMENT

- Remove the air cleaner.
- Remove the air intake hose at the blower housing. This will permit you to see the timing marks.
- For top adjust points: Remove the point box cover.
 - For rear adjust points: Remove battery and baffling. Remove rear point cover.
- Rotate the flywheel in a clockwise direction until the "TC" mark lines up with the 0° mark on the cam gear cover.
- Remove the old point set and condenser and install the new point set and condenser.
- Set the point gap at .021" (.52 mm) [.020" (.51 mm for 646)]
- Proceed with the ignition timing procedure.

IGNITION TIMING PROCEDURE

1. Remove air cleaner.
2. Remove the air intake hose at the blower housing. This will permit you to see the timing marks.
3. (a) For top adjust points: Remove the point box cover.

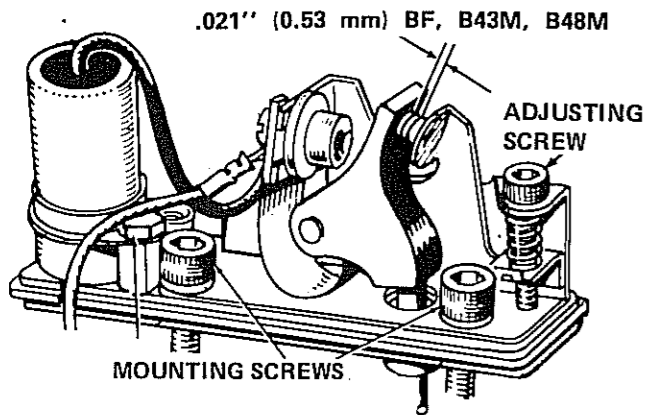

FIGURE 33 Top Adjust Points

- (b) For rear adjust points: Remove battery and baffles. Remove rear point cover.

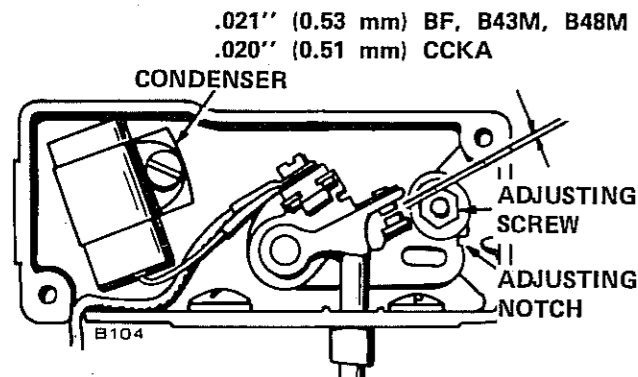

FIGURE 34 Rear Adjust Points

4. (a) For BF, B43, B48 engines:

Rotate the flywheel in a clockwise direction until the "TC" mark lines up with the 21° BTC mark on the cam gear cover.

The "TC" mark is a raised line on one of the 3 wide webs on the outer circumference of the flywheel. The TC mark is forward of the flywheel ring gear.

The degree marks are located on the cam gear cover just behind the flywheel ring gear. The degree numbers are raised numerals on the rear lip of the cam gear cover. See Figure 35.

- b) For CCKA engines:

Rotate the flywheel in a clockwise direction until the "TC" mark lines up with the 20° BTC mark on the cam gear cover.

The letters "TC" are located on the front face of the flywheel with a line extending to the edge of the flywheel.

The degree marks are located on the cam gear cover just behind the flywheel ring gear. The degree numbers are raised numerals on the rear lip of the cam gear cover. See Figure 35.

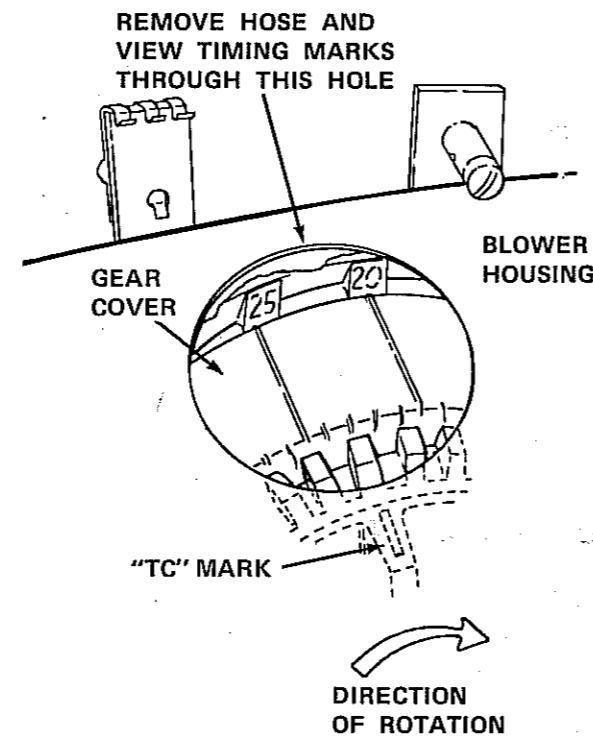

FIGURE 35 Timing Adjustment BF, B43, B48

5. Mark a line between the rotating air screen (flywheel on 646) and the blower housing. This new timing mark will then be used to correctly time the engine.
6. Connect the timing light in accordance with its manufacturers instructions. Use either spark plug because they fire at the same time.
7. For units with rear adjust points, connect the battery with jumper cables.
8. Make sure that nothing can enter the carburetor throat.
9. Start and run the engine. Change the breaker point gap until the timing marks line up.

COIL SERVICE

INSPECTION

The ignition coil should be kept clean and dry and connections must be kept tight. The boots on the high tension terminal must be in good condition to prevent leakage of current across exposed surfaces.

INSTALLATION

The coil must be installed with the primary positive (+) terminal connected to battery positive (+) (from key switch). The coil negative (-) must be connected to the breaker points and condenser.

OHMMETER TEST FOR COIL PRIMARY WINDING

1. Select RX 1 scale on ohmmeter.
2. Zero ohmmeter needle.
3. Connect one ohmmeter lead to coil "+" terminal, the other to coil "-" terminal.
4. Resistance should be from 4 to 5 ohms.

Infinite resistance indicates open primary circuit. Less than specified resistance indicates a shorted primary circuit.

OHMMETER TEST FOR COIL SECONDARY WINDING

1. Select RX 1,000 scale on ohmmeter.
2. Zero ohmmeter needle.
3. Connect the ohmmeter leads to the coil spark plug terminals.
4. Resistance should be about 12,000 to 16,000 ohms.

Infinite resistance indicates an open secondary circuit. Substantially less than specified resistance indicates a shorted secondary circuit.

OHMMETER TEST FOR GROUNDED WINDINGS

1. Select RX 1,000 scale on ohmmeter.
2. Zero ohmmeter needle.
3. (a) Connect one ohmmeter lead to coil "-" terminal, the other to metal case of coil.
(b) Connect one ohmmeter lead to one coil secondary terminal, the other to metal case of coil.
4. Infinite resistance indicates a good coil. Continuity indicates a grounded coil.

NOTE: Do not touch ohmmeter leads with fingers when performing this test.

OHMMETER TEST FOR PRIMARY TO SECONDARY SHORT CIRCUITRY

1. Select RX 1,000 scale on ohmmeter.
2. Zero ohmmeter needle.
3. Connect one ohmmeter lead to either coil primary terminal and the other ohmmeter lead to either coil secondary terminal.
4. Infinite resistance indicates a good coil. Continuity indicates a shorted coil.

NOTE: Do not touch ohmmeter leads with fingers when performing this test.

A coil testing "good" with the ohmmeter test is not conclusive. Coils may fail intermittently when subjected to load, heat, and vibration of a running engine. The use of a spark tester or coil tester will complete the testing of coil output.

COIL TESTER TEST

Follow the instructions provided with the coil tester. If a coil tester is not available, the spark tester check can be used.

SPARK TESTER TEST

1. Connect spark tester ground clip to engine ground.
2. Connect spark plug wire to test terminal of spark tester.
3. Crank engine.
4. A sharp blue spark should be visible.
5. Connect spark tester ground clip to spark plug. (Now spark tester is in series with engine spark plug.)
6. Start and operate engine under load. Presence of spark (coil output) can be monitored during operation.

CONDENSER SERVICE

Condenser shorted to ground will prevent coil from producing secondary voltage.

Condenser with open circuit or decreased capacitance reduces coil output voltage and will cause points to burn excessively.

Condenser with too little capacitance will cause metal to build up on the moveable contact.

Condenser with too much capacitance will cause metal to build up on the stationary contact.

Replace condenser with proper one as indicated in parts listing.

OHMMETER TEST

1. Remove condenser.
2. Select RX 10K scale on ohmmeter. Zero the meter.
3. Touch one ohmmeter lead to the condenser case and the other ohmmeter lead to the condenser lead.

NOTE: Do not touch ohmmeter prods or condenser case or lead while performing this test.

4. Reverse the ohmmeter leads on the condenser. A properly operating condenser will cause the ohm needle to move slightly each time the leads are reversed and touched to the condenser.
5. If the needle does not move or if a constant low resistance reading occurs, the condenser is defective.

SPARK PLUG

SYMPTOMS

Spark plugs in poor condition or gapped improperly can cause engine misfire and poor operation.

Refer to Figures 36, 37 and 38 for examples of failed spark plugs. Correct the cause of the failure before returning the engine to service.

SERVICE

Every 50 hours remove plug, check condition and reset gap.

CLEAN AREA around plug before removal.

DO NOT sandblast, wire brush, scrape or otherwise service plug in poor condition--best results are obtained with new plug.

Set spark gap at .025" (0.64 mm) for standard plugs and for resistor plugs. Tighten plug to 27 lbs. ft. (37 Nm) with a torque wrench.

SPARK PLUG SPECIFICATIONS — ALL MODELS

Plug Type Champion RH18Y or equivalent
Plug Size 14 mm
Hex Size 13/16"
Plug Reach 7/16"

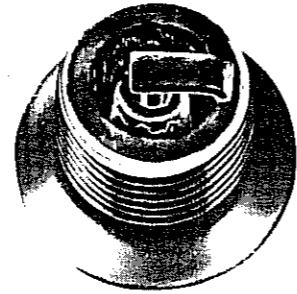

FIGURE 36 Oil Fouled Spark Plug

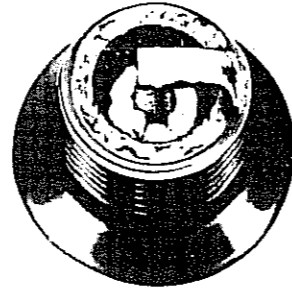

FIGURE 37 Overheated Spark Plug

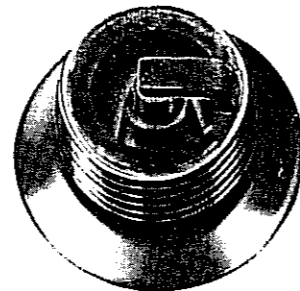

FIGURE 38 Fuel Fouled Spark Plug

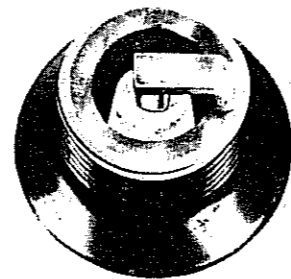
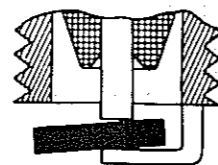
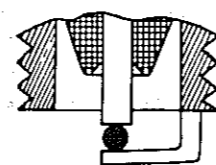

FIGURE 39 Spark Plug With Normal Wear



FLAT FEELER GAUGE CAN GIVE FALSE READING



ROUND FEELER GAUGE WILL GIVE A MORE ACCURATE READING

FIGURE 40 Spark Plug Gap