

Ingersoll

HYDRAULIC PUMP
Compact Tractors
Service Manual 9-99665



Ingersoll . . . *the new name to say for Case garden tractors.*

Ingersoll Equipment Co., Inc. Winneconne, Wisconsin 54986-9576

MyTractorForum.com



This Safety Alert Symbol Indicates Important Safety Messages In This Manual When You See This Symbol Carefully Read The Message That Follows and Be Alert To The Possibility Of Personal Injury Or Death

IF THIS MACHINE IS USED BY AN EMPLOYEE OR IS LOANED OR RENTED, MAKE ABSOLUTELY CERTAIN THAT THE OPERATOR(S), PRIOR TO OPERATING:

- 1. IS INSTRUCTED IN SAFE AND PROPER USE.**
- 2. REVIEWS AND UNDERSTANDS THE MANUAL(S) PERTAINING TO THE MACHINE.**

751253



WARNING

BEFORE STARTING ENGINE

**STUDY OPERATOR'S MANUAL SAFETY MESSAGES
READ ALL SAFETY SIGNS ON MACHINE
CLEAR THE AREA OF OTHER PERSONS**

LEARN & PRACTICE SAFE USE OF CONTROLS BEFORE OPERATING

IT IS YOUR RESPONSIBILITY TO UNDERSTAND AND FOLLOW MANUFACTURER'S INSTRUCTIONS ON MACHINE OPERATION, SERVICE, AND TO OBSERVE PERTINENT LAWS AND REGULATIONS. OPERATOR AND SERVICE MANUALS MAY BE OBTAINED FROM YOUR EQUIPMENT DEALER.

TABLE OF CONTENTS

SECTION 1	
Pump Removal	2 - 3
SECTION 2	
Pump Installation	3
SECTION 3	
Pump Disassembly, Inspection, and Assembly Procedures	4 - 21
Wooster Pump (C14243 and C14244)	5
Parker Hannifin Pump (C15481 and C19045)	6 - 8
Borg Warner Pump (C20757, C19743 and C22771)	10 - 11
Parker Hannifin Pump (C24828, C24868 and C25053)	12 - 14
Cessna Pump (C25179)	16 - 17
Borg Warner Pump (C19176, C20025, C20122 and C23951)	18 - 19
Cessna Pump (C25287)	20 - 21

INTRODUCTION

This manual has service information for the hydraulic pumps used on all 200, 400 and 600 series tractors.

See your parts catalog for the part number of the pump.

See your "HYDRAULIC TEST PROCEDURES" service manual section for pump performance specifications and testing procedures.

SECTION 1

PUMP REMOVAL

FOR TRACTORS BEFORE P.I.N. 9646800

(with panels that can be removed on the side of the instrument tower)

TRACTORS WITH MECHANICAL LIFT

1. Drain the hydraulic system.
2. Remove the panel from the R.H. side of the control tower.
3. Disconnect the inlet and outlet tubes from the pump.
4. Fasten the choke and throttle cables up to clear the work area.
5. Remove the pump support from the engine. Pull the pump and support through the R.H. side of the control tower.
6. Mark the position of the coupling on the pump shaft for a guide during assembly.
7. Loosen the set screw and remove the coupling.
8. Remove the pump from the support.

TRACTORS WITH HYDRAULIC LIFT

1. Drain the hydraulic system.
2. Remove the panel from the L.H. side of the control tower.
3. Disconnect the inlet and outlet tubes from the pump. Remove the outlet tube from the tractor.
4. Remove the L.H. foot rest.
5. Disconnect the brake rod and spring from the brake pedal.
6. Slide the brake pedal off the shaft by holding the travel control lever of the tractor in the down position.
7. Remove the pump support from the engine. Pull the pump and support through the L.H. side of the control tower.
8. Mark the position of the coupling on the pump shaft for a guide during assembly.
9. Loosen the set screw and remove the coupling.
10. Remove the pump from the support.

FOR TRACTORS BETWEEN P.I.N. 9646800 AND

220 - 9702946
222 - 9706651
224 - 9708665
444 - 9711027
446 - 9728158

(with external muffler but no side panels that can be removed)

1. Drain the hydraulic system.
2. Remove the battery and battery mounting plate.
3. Disconnect the lines to the pump and put a cap on them to prevent the entry of dirt.
4. Remove the four (4) bolts holding the pump support to the engine.
5. Pull the pump and pump support up through the area where the battery was.
6. Mark the coupling position on the pump shaft for a guide during assembly.
7. Loosen the set screw and remove the coupling half.
8. Remove the bolts holding the pump to the pump support.

FOR TRACTORS BETWEEN P.I.N.

220 - 9702946 - 9734870
222 - 9706651 - 9766998
224 - 9708665 - 9738335
444 - 9711027 - 9739739
446 - 9728158 - 9742953

(with the muffler under the hood and metal reservoir)

1. Drain the hydraulic system.
2. Remove the battery.
3. Remove the voltage regulator and solenoid from the battery tray. Do not remove the wires from the voltage regulator and solenoid.
4. Remove the battery tray.
5. Remove the suction line and return line from the reservoir.
6. Remove the reservoir.
7. Disconnect the lines from the pump.

8. Remove the four (4) bolts holding the pump support to the engine.
9. Pull the pump and pump support up through the area where the battery and reservoir were.
10. Mark the coupling position on the pump shaft for a guide during assembly.
11. Loosen the set screw and remove the coupling half.
12. Remove the bolts holding the pump to the pump support.

FOR TRACTORS AFTER P.I.N.

220 - 9734870
222 - 9766998
224 - 9738335
444 - 9739739
446 - 9742953
448 - All

(with muffler under the hood and special plastic reservoir)

1. Drain the hydraulic system.
2. Remove the battery.
3. Remove the access cover from the control tower.
4. Disconnect the lines from the hydraulic pump.
5. Remove the right and left heat exchanger brackets.
6. Remove the four engine mounting bolts.

SECTION 2

PUMP INSTALLATION (ALL MODELS)

1. Install the pump by using the procedure opposite that of removal.
2. Make sure that the drive coupling halves are fully engaged, but do not compress the flexible center section.
3. Tighten the set screws.
4. Make sure you connect the battery ground wire to the pump support bolt.
5. Fill the reservoir to the correct level and with the correct oil. See your operator's manual.

7. Slide the engine ahead a small amount.
8. Disconnect the return line from the reservoir.
9. Remove the reservoir.
10. Remove the four (4) bolts holding the pump support to the engine.
11. Remove the pump and pump support through the area that the reservoir and battery were.
12. Mark the coupling position on the pump shaft for a guide during assembly.
13. Loosen the set screw and remove the coupling half.
14. Remove the bolts holding the pump to the pump support.

FOR LOADER TRACTORS 644 AND 646 (ALL)

1. Remove the battery and the mounting plate for the battery.
2. Remove the access panel from the control tower.
3. Disconnect the hydraulic lines at the pump. Put a cap on the lines to keep dirt out.
4. Disconnect the inlet line at the loader valve. Loosen this line at the travel valve.
5. Remove the two pump mounting bolts.
6. Loosen the two set screws in the pump coupling.
7. Remove the pump through the top of the tractor.

6. Start and run the tractor at half throttle for 30 seconds. Operate all the hydraulic controls.
7. Check the oil level and add oil if necessary.
8. Start and run the tractor:
 - a. at half throttle and apply short intervals of load for 3 minutes, and
 - b. at full throttle and apply short intervals of load for 3 minutes.
9. Stop the tractor and check for leaks.

SECTION 3

PUMP DISASSEMBLY, INSPECTION, AND ASSEMBLY PROCEDURES

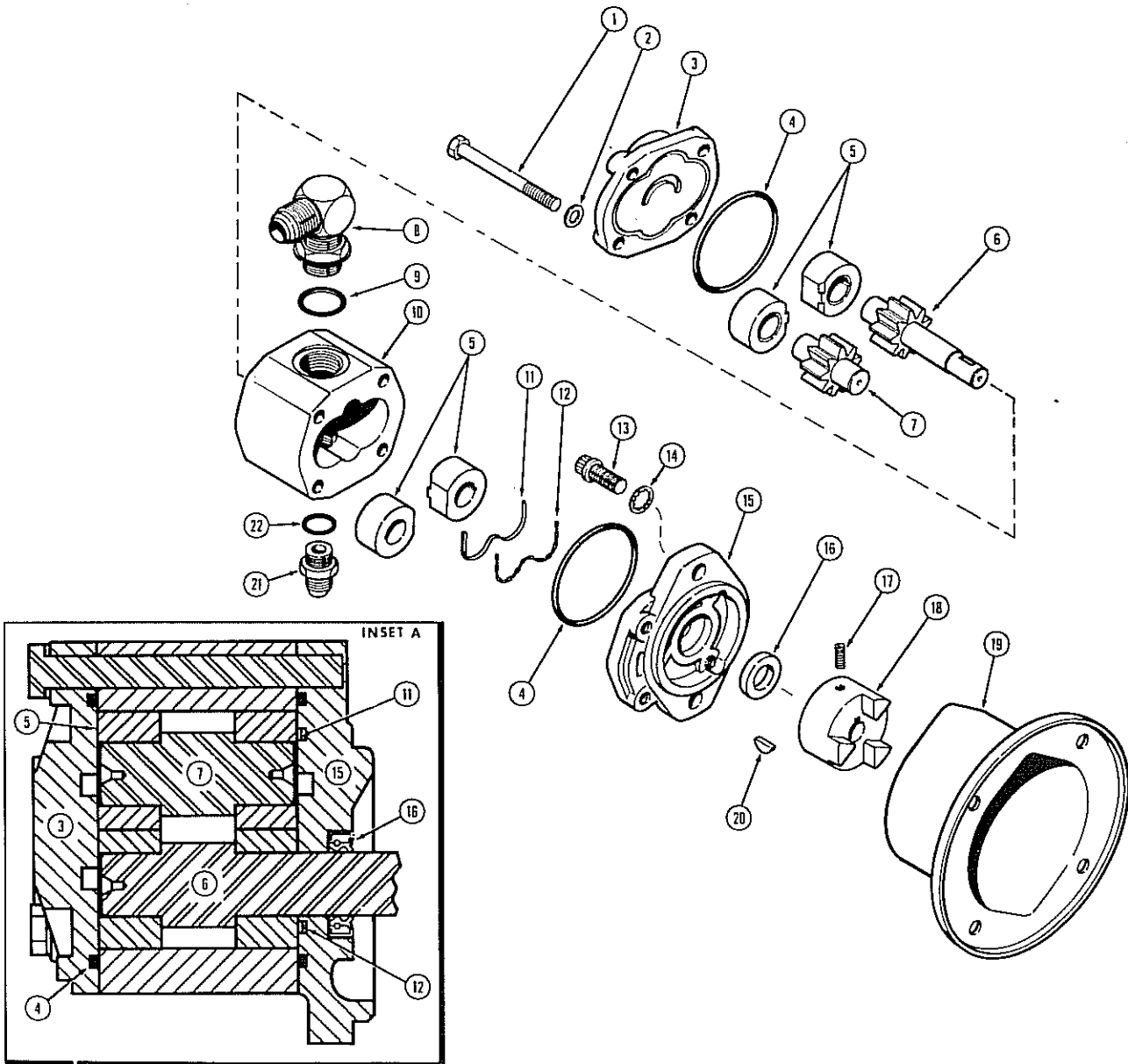

FIGURE 1

WOOSTER PUMP

Part Numbers C14243, C14244

For 220, 222, 442, 444 before P.I.N. 9641000.

DISASSEMBLY

IMPORTANT: Before disassembly, make a mark across the pump cover and body. Use this mark for alignment during assembly.

1. Remove the 90 degree fitting (8) and "O" ring (9). Remove the straight fitting (21) and the "O" ring (22).
2. Remove bolts (1), washers (2), and cover (3) from the body (10). Remove the seal (4) from the cover (3).
3. Remove the adapter cover (15) and remove the seal (4), brass seal (11), rubber spacer (12) and seal (16).
4. Remove the drive gear (6), driven gear (7) and bearings (5) from the body (10).

INSPECTION

Completely clean all the parts before inspection. Replace all worn or damaged parts.

Check all metal parts for scoring or other damage. Small scratches can be removed with a hone or crocus cloth.

Check the gears for damaged teeth.

Replace the spacer and all seals and gaskets each time the hydraulic pump is disassembled.

ASSEMBLY

1. Lubricate all the parts, except the seal, with a clean SAE No. 10 oil during assembly.
2. Apply a light coat of Permatex No. 3, or equivalent, to the bore of the cover (15). With the seal lip to the inside, press a new oil seal (16) fully into the cover. See Inset A.
3. With the chamfer toward the gear, assemble the bearings (5) on the gears (6 and 7). Put this assembly into the pump body (10).
4. Put the rubber spacer (12) in the front cover (15), then install the brass seal (11) and the seal (4).
5. Install the seal (4) in the rear cover (3).
6. Install both the covers on the body. Align the marks made during disassembly.

IMPORTANT: Be careful while installing the cover on the gear shaft so the oil seal is not damaged.

7. Install the bolts (1) and washers (2). Tighten to a torque of 28 to 32 ft. lb. (39 to 43 Nm).
8. Install the key (20) and drive coupling (18). Tighten the set screw (17) in the coupling hub.
9. Install the pump support (19) using the washers (14) and cap screws (13).
10. Install the 90 degree fitting (8) and "O" ring (9). Install the straight fitting (21) and "O" ring (22).

PARKER HANNIFIN PUMP

Part Numbers C15481, C19045

For Models

220 P.I.N. 9641001 to P.I.N. 9674235

222 P.I.N. 9641001 to P.I.N. 9681170

224 P.I.N. 9667000 to P.I.N. 9676354

442 All

444 P.I.N. 9641001 to 9677449

446 Before P.I.N. 9728158

644 Before P.I.N. 9698284

DISASSEMBLY

1. Remove the key (15) from the drive shaft. If the key cannot be removed with a pliers:
 - a. tighten the key in a vise with a square jaw
 - b. lift the rear of the pump.
2. Completely clean all external areas of the pump with a solvent.
3. Put a mark across all three sections of the pump. This mark will align the sections during assembly.
4. Remove the four bolts (14) that hold the three pump sections together.
5. Separate the three pump sections. Do not use a pry-bar as this will cause damage. If necessary use this procedure:
 - a. hold the pump in a vertical position with the front cover (7) toward the top.
 - b. lightly hit the sides of the back cover (3) with a soft hammer.

c. as the sections separate make sure the sections are parallel. This will prevent damage of the dowel pins (2).

6. Remove the wear plate (10).
7. Put a mark on the side of the front cover next to the small pressure hole in the heat shield (11). This mark will be a guide for correct alignment of the pressure hole. Remove the heat shield (11), gasket (12) and seal (13) by putting a small wire into the pressure hole.
8. Remove the "O" rings (5) from the inside face of both front and back covers (3 and 7).
9. Do not remove the shaft seal (8) unless:
 - a. the seal was leaking or
 - b. wear or damage can be seen.

If replacement is necessary, carefully remove the seal to prevent damage to the cover bore. Use the following procedure:

- a. heat the cover to approximately 250°F (120°C)
- b. Use a small internal puller that will make contact with the steel retainer section of the seal.
- c. Pull the seal straight and even to prevent damage to the cover bore.

INSPECTION

1. Completely clean and air dry all parts before inspection. Replace all worn or damaged parts.

WEAR TOLERANCE CHART

Gear Shaft Diameter	.4993" (12.682 mm) Minimum
Gear Diameter	1.2390" (26.639 mm) Minimum
Gear Width	1.0557" (26.456 mm) Minimum
Cover Bearing I.D.	.5025" (12.764 mm) Maximum
Gear Wear Ridge in Back Cover and Wear Plate	.0005" (0.013 mm) Maximum
Gear Bore Diameters in Center Section	1.243" (31.572 mm) Maximum

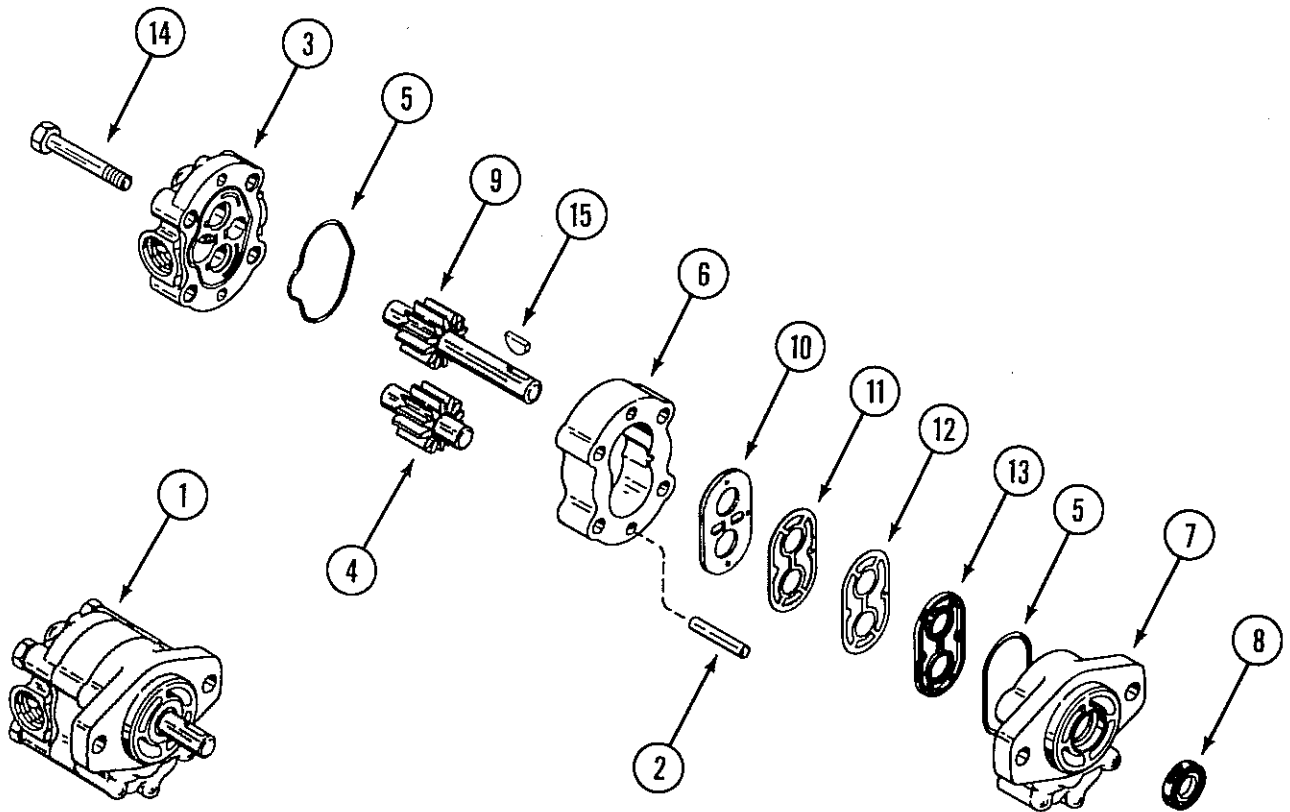

FIGURE 2

NOTE: The thickness of the center section (6) must be between .0002" and .0018" (0.005 and 0.045 mm) wider than the width of the gears.

2. Check the gear shafts and tooth faces and sides for damage or sharp edges. Small defects can be removed with emery cloth. Do not use emery cloth on the edges of the gear O.D.
3. Check the positions of the bearings in the covers. These bearings are pressed fit and are not replaceable. The correct position for these bearings are as follows:
 - a. The split in the bearings must not be more than 1/16" (1.58 mm) from a vertical center line through both bearings.
 - b. The bearing in the front cover must be even with the face of the bearing bore.
 - c. The bearing in the rear cover must be recessed below the face of the bearing bore.

Check the ends of the bearings for wear. There must not be any wear due to contact with the retaining rings of the gears.

4. Remove any small defects from the faces of the covers and center section. Do not damage any square edges while repairing defects.

Follow this procedure to repair the faces of the covers and center section:

- a. Put a No. 320 emery cloth on a flat surface.
- b. Slide the face on this surface to repair the damage.

Also use this procedure to remove the wear ridge from the surface of the back cover.

5. Replace the seals, gaskets and wear plate each time the pump is disassembled. Do not replace the shaft seal unless this seal is damaged. See Paragraph 9 under disassembly.

ASSEMBLY

1. Make sure all parts are completely clean. Select a clean area for assembly. Lubricate each part, except the shaft seal, with clean SAE No. 10 oil.
2. If a new shaft seal is needed, follow this procedure for installation:
 - a. Put the cover (7) on a flat clean surface, with the face down.

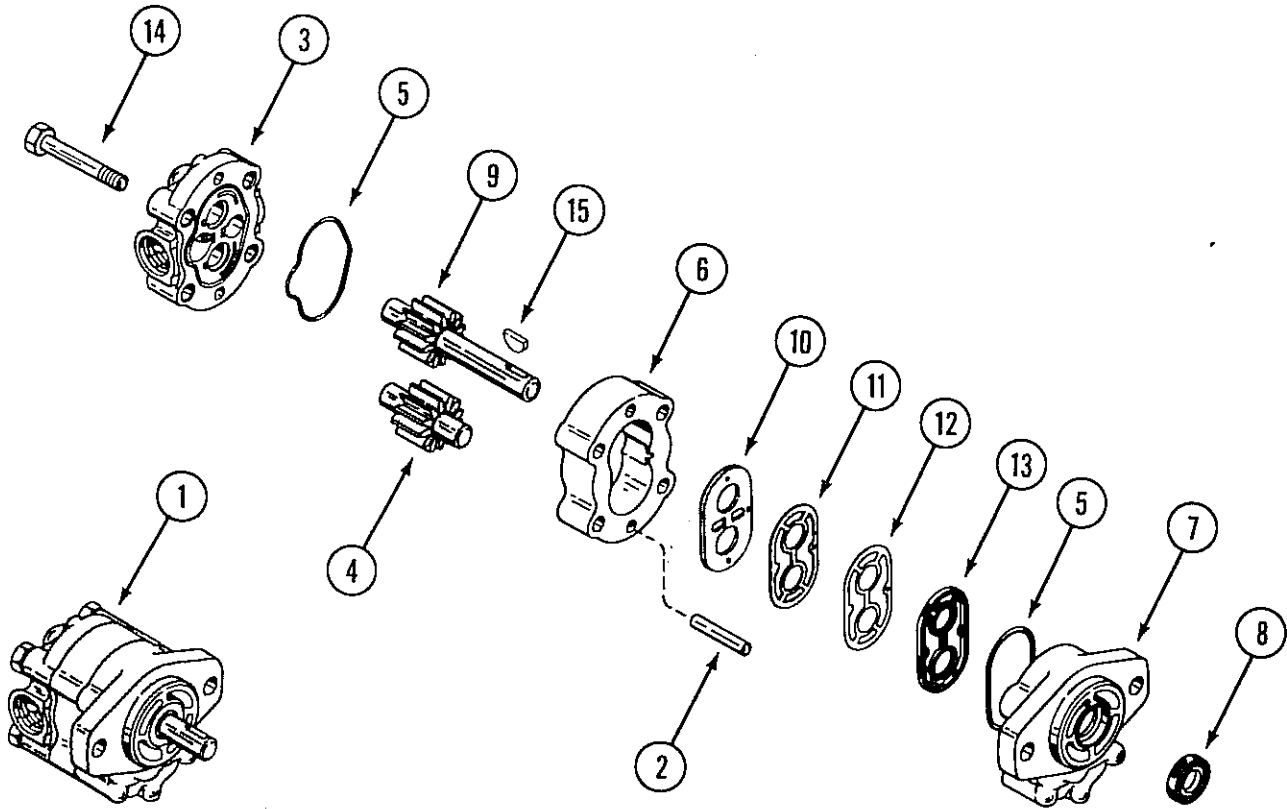

FIGURE 3

- b. Put the seal in position with the sealing lip toward the inside of the cover.
 - c. Use a steel rod with a flat end that is larger than the seal O.D. Hold the rod exactly vertical. Press the seal evenly into the cover bore until the seal is level with the rim.
3. Install the rubber seal (13) with the lip side down and the oil hole next to the mark you made. Use a tool with a round head to prevent damage to the surface areas.
 4. Install the gasket (12). The oil hole must be aligned with the mark on the cover. Press this gasket tightly into the recessed area. Make sure the gasket is completely installed before further assembly.
 5. Press the heat shield (11) tightly over the gasket (12). Make sure the oil holes are aligned correctly.
 6. Apply oil to the faces of the front and back covers. Install the "O" rings (5). Make sure the "O" rings cannot fall out of the grooves.
 7. Install the wear plate (10) over the heat shield. Make sure the oil holes are aligned and the bronze surface is toward the outside. Press until the wear plate is approximately even with the face of the cover. Be careful that you do not bend this plate.
 8. Install the drive gear (9) and the driven gear (4) into the front cover. If you do not have a 1/2" (12.7 mm) seal protector, use the following procedure for installation:
 - a. Remove all sharp edges from the chamfer and keyway of the shaft.
 - b. Apply a layer of oil on the shaft.
 - c. With a rotating motion, push the shaft through the seal.
 9. Put the center section (6) over the gears and on the front cover. Make sure the guide marks are aligned and the wear plate and "O" ring are seated.
 10. Install the dowel pins (2). Add a large amount of oil to the gear cavities and rotate the gears.
 11. With the guide marks aligned install the back cover. Make sure the wear plate is still in place. Install the cap screws and tighten to a torque 24 to 26 ft. lb. (33 to 35 Nm).
 12. Add a large amount of oil to both pump ports. Manually rotate the shaft for oil distribution and to make sure the shaft has free movement.

BORG WARNER PUMP

Part Numbers C20757, C19743, C22771

For Models:

- 220 P.I.N. 9674235 to P.I.N. 9734870
- 222 P.I.N. 9681170 to P.I.N. 9736998
- 224 P.I.N. 9676354 to P.I.N. 9738335
- 444 P.I.N. 9677449 to P.I.N. 9739739
- 446 P.I.N. 9728158 to P.I.N. 9742953
- 644 P.I.N. 9698284 to P.I.N. 9757937

DISASSEMBLY

1. Remove the key (5) from the drive shaft. If the key cannot be removed with a pliers:
 - a. Tighten the key in a vise with square jaws.
 - b. Lift the rear of the pump.
2. Completely clean all external areas of the pump with a solvent similar to kerosene.
3. Put a mark across the pump sections for alignment during assembly.
4. Remove the four bolts (10) that hold the two pump sections together.

5. Put a screwdriver in each slot on opposite sides of the pump body. Carefully separate the two sections.
6. Remove the "O" ring (8) from the pump cover (9).
7. Remove the driven gear (7) from the pump body (3).
8. Remove the snap ring (1) from the drive gear shaft (6). Remove the drive gear from the pump body.
9. Remove the wear plate assembly (4) from the pump body (3).
10. Remove the pressure load seal (4b) from the wear plate (4a).
11. Do not remove the shaft seal (2) unless:
 - a. the seal was leaking or
 - b. wear or damage can be seen.

If replacement is necessary, carefully remove the seal to prevent damage to the cover bore. Use the following procedure:

- a. Heat the cover to approximately 250°F (120°C).
- b. Use a small internal puller that will make contact with the steel retainer section of the seal.
- c. Pull the seal straight and even to prevent damage to the cover bore.

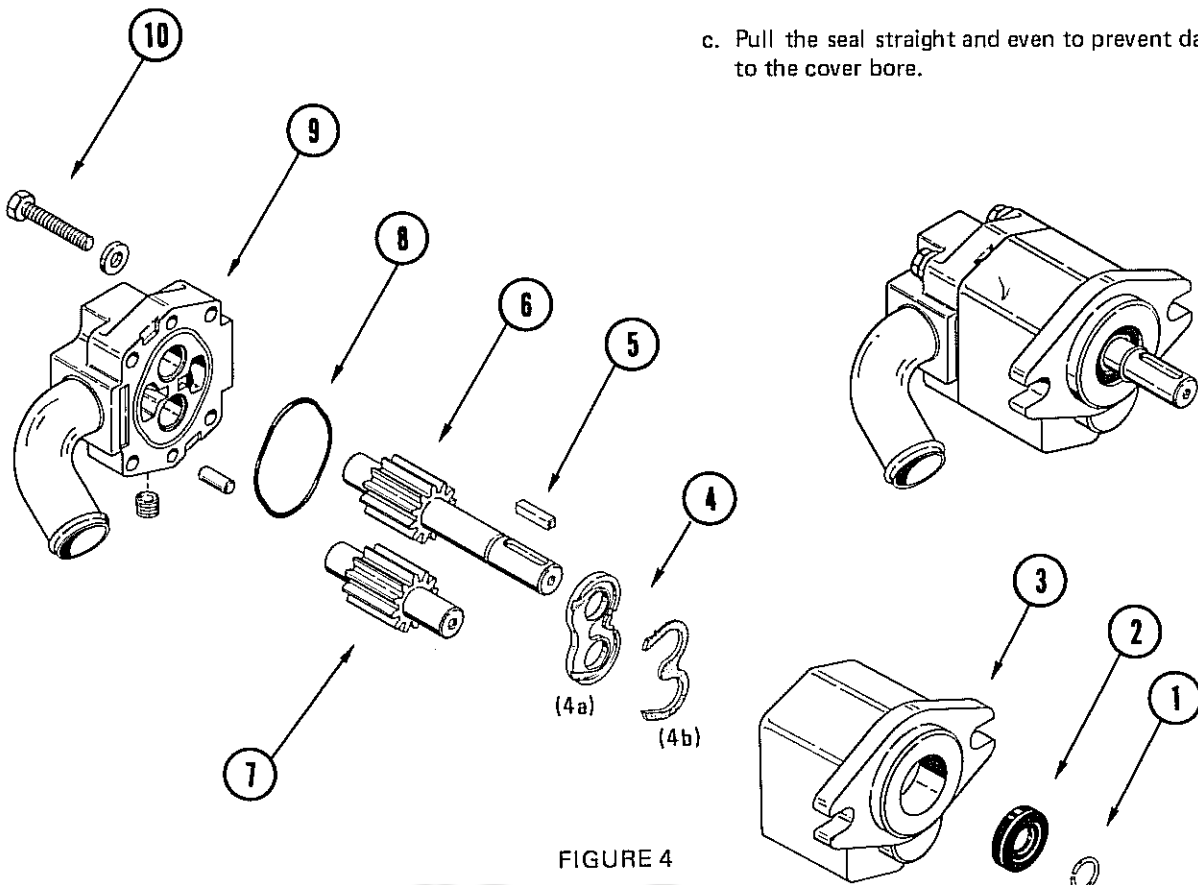

FIGURE 4

INSPECTION

1. Completely clean and air dry all parts before inspection. Replace all worn or damaged parts.
2. Check the gear shafts and tooth faces and sides for damage or sharp edges. Small defects can be removed with emery cloth. Do not use emery cloth on the edges of the gear O.D.
3. Check the positions of the bearings in the covers. These bearings are pressed fit and are not replaceable. The correct position for these bearings is as follows:
 - a. The split in the bearings must not be more than 1/6" (1.58 mm) from a vertical center line through both bearings.
 - b. The bearing in the front cover must be even with the face of the bearing bore.
 - c. The bearing in the rear cover must be recessed below the face of the bearing bore.
4. Remove any small defects from the faces of the covers and center section. Do not damage any square edges while repairing defects.

Follow this procedure to repair the faces of the covers and center section:

- a. Put a No. 320 emery cloth on a flat surface.
- b. Slide the face on this surface to repair the damage.

Also use this procedure to remove the wear ridge from the surface of the back cover.

5. Replace the seals, gaskets and wear plate each time the pump is disassembled. Do not replace the shaft seal unless this seal is damaged. See Paragraph 11 under disassembly.

ASSEMBLY

1. Make sure all parts are completely clean. Select a clean area for assembly. Lubricate each part, except the shaft seal, with a clean SAE No. 10 oil.
2. If a new shaft seal is needed, follow this procedure for installation:
 - a. Put the pump body (3) on a flat clean surface with the face down.
 - b. Put the seal in position with the sealing lip toward the inside of the body.

- c. Use a steel rod with a flat end that is larger than the seal O.D. Hold the rod exactly vertical. Press the seal evenly into the body bore until the seal is .188" (4.78 mm) below the rim. Make sure the seal does not prevent the flow of oil through the oil passage.
3. Install the pressure load seal (4b) in the wear plate (4a).
4. Install the wear plate assembly (4) into the pump body (3). Make sure the seal (4b) is toward the casting.
5. Install the drive gear (6) into the body (3). If you do not have a seal protector, use the following procedure for installation:
 - a. Remove all sharp edges from the chamfer, keyway and groove for the snap ring.
 - b. Apply a layer of oil on the shaft.
 - c. With a rotating motion, push the shaft through the seal. Install the snap ring on the shaft.
6. Install the driven gear (7) in the body (3). The long end of the shaft goes into the body.
7. Fit the "O" ring (8) into the groove in the pump cover (9).
8. Align the guide marks on the pump body and cover. Install the cover.
9. Install the four retaining bolts. Tighten to a torque of 28 to 32 lb. ft. (38-43 Nm).

PARKER HANNIFIN PUMP

Part Numbers C24828, C24868 (Service Pump)
C25053 (Service Pump)

For Some Models.

220 - P.I.N. 9734870 and after
222 - P.I.N. 9736998 and after
224 - P.I.N. 9738335 and after
444 - P.I.N. 9739789 and after
446 - P.I.N. 9742935 and after
448 - All
644 - P.I.N. 9757937 and after

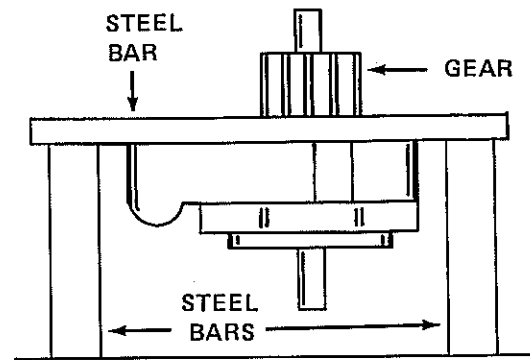

DISASSEMBLY

FIGURE 5

1. Remove the key (15) from the drive shaft. If the key cannot be removed with a pliers:
 - a. tighten the key in a vise with a square jaw
 - b. lift the rear of the pump.
2. Completely clean all external areas of the pump with a solvent.
3. Put a mark across all three sections of the pump. This mark will align the sections during assembly.
4. Remove the four bolts (14) that hold the three pump sections together.
5. Separate the three pump sections. Do not use a prybar as this will cause damage. If necessary use this procedure:
 - a. hold the pump in a vertical position with the front cover (7) toward the top.
 - b. lightly hit the sides of the back cover (3) with a soft hammer.
 - c. as the sections separate make sure the sections are parallel. This will prevent damage of the dowel pins (2).
6. Remove the spiral retaining ring from the upper gear shaft.
7. Put a thin hard steel bar between the gear and the front cover and under each side of the gear.
8. Put this assembly in a press. Support the assembly on the ends of the hard steel bars.
9. Use the press to remove the gear from the shaft.
10. Remove the key and second spiral retaining ring.
11. Pull the shaft through the front cover bushing and seal.
 12. Remove the wear plate (10).
 13. Put a mark on the side of the front cover next to the small pressure hole in the heat shield (11). This mark will be a guide for correct alignment of the pressure hole. Remove the heat shield (11), gasket (12) and seal (13) by putting a small wire into the pressure hole.
 14. Remove the "O" rings (5) from the inside face of both front and back covers (3 and 7).
 15. Do not remove the shaft seal (8) unless:
 - a. the seal was leaking or
 - b. wear or damage can be seen.If replacement is necessary, carefully remove the seal to prevent damage to the cover bore. Use the following procedure:
 - a. heat the cover to approximately 250°F (12°C).
 - b. Use a small internal puller that will make contact with the steel retainer section of the seal.
 - c. Pull the seal straight and even to prevent damage to the cover bore.

INSPECTION

1. Completely clean and air dry all parts before inspection. Replace all worn or damaged parts.

NOTE: The thickness of the center section (6) must be between .0002" and .0018" (0.005 and 0.045 mm) wider than the width of the gears.

2. Check the gear shafts and tooth faces and sides for damage or sharp edges. Small defects can be removed with emery cloth. Do not use emery cloth on the edges of the gear O.D.

WEAR TOLERANCE CHART

Gear Shaft Diameter	.4993" (12.682 mm) Minimum
Gear Diameter	1.2390" (26.639 mm) Minimum
Gear Width	1.0557" (26.456 mm) Minimum
Cover Bearing I.D.	.5025" (12.764 mm) Maximum
Gear Wear Ridge in Back Cover and Wear Plate	.0005" (0.013 mm) Maximum
Gear Bore Diameters in Center Section	1.243" (31.572 mm) Maximum

3. Check the positions of the bearings in the covers. These bearings are pressed fit and are not replaceable. The correct position for these bearings are as follows:

- The split in the bearings must not be more than 1/16" (1.58 mm) from a vertical center line through both bearings.
- The bearing in the front cover must be even with the face of the bearing bore.
- The bearing in the rear cover must be recessed below the face of the bearing bore.

Check the ends of the bearings for wear. There must not be any wear due to contact with the retaining rings of the gears.

4. Remove any small defects from the faces of the covers and center section. Do not damage any square edges while repairing defects.

Follow this procedure to repair the faces of the covers and center section:

- Put a No. 320 emery cloth on a flat surface.
- Slide the face on this surface to repair the damage.

Also use this procedure to remove the wear ridge from the surface of the back cover.

5. Replace the seals, gaskets and wear plate each time the pump is disassembled. Do not replace the shaft seal unless this seal is damaged. See Paragraph 15 under disassembly.

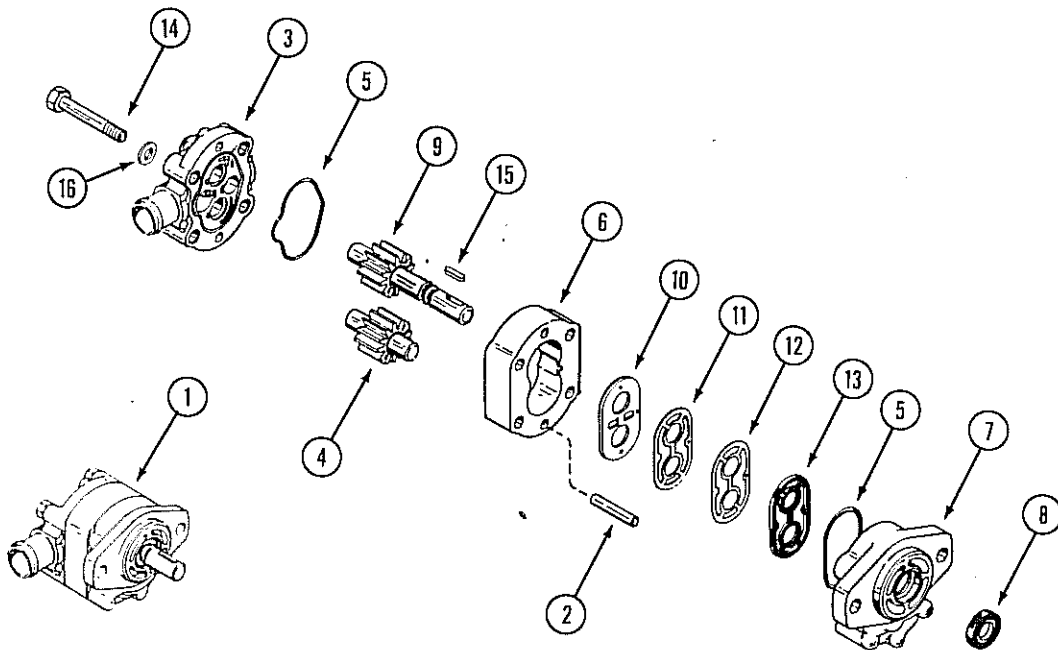

FIGURE 6

ASSEMBLY

1. Make sure all parts are completely clean. Select a clean area for assembly. Lubricate each part, except the shaft seal, with clean SAE No. 10 oil.
2. If a new shaft seal is needed, follow this procedure for installation:
 - a. Put the cover (7) on a flat clean surface, with the face down.
 - b. Put the seal in position with the sealing lip toward the inside of the cover.
 - c. Use a steel rod with a flat end that is larger than the seal O.D. Hold the rod exactly vertical. Press the seal evenly into the cover bore until the seal is level with the rim.
3. Install the rubber seal (13) with the lip side down and the oil hole next to the mark you made. Use a tool with a round head to prevent damage to the surface areas.
4. Install the gasket (12). The oil hole must be aligned with the mark on the cover. Press this gasket tightly into the recessed area. Make sure the gasket is completely installed before further assembly.
5. Press the heat shield (11) tightly over the gasket (12). Make sure the oil holes are aligned correctly.
6. Apply oil to the faces of the front and back covers. Install the "O" rings (5). Make sure the "O" rings cannot fall out of the grooves.
7. Install the wear plate (10) over the heat shield. Make sure the oil holes are aligned and the bronze surface is toward the outside. Press until the wear plate is approximately even with the face of the cover. Be careful that you do not bend this plate.
8. Install the upper gear shaft in the front cover. If you do not have a 1/2" (12.7 mm) seal protector, use the following procedure for installation:
 - a. Remove all sharp edges from the chamfer and keyway of the shaft.
 - b. Apply a layer of oil on the shaft.
 - c. With a rotating motion, push the shaft through the seal.
9. Install the spiral retaining ring in the groove nearest to the cover.
10. Install the key in the keyway.
11. Heat the gear to 275°F (135°C) and install on the shaft and key.
12. Install the second spiral retaining ring.
13. Install the bottom shaft and gear.
14. Put the center section (6) over the gears and on the front cover. Make sure the guide marks are aligned and the wear plate and "O" ring are seated.
15. Install the dowel pins (2) if needed. Add a large amount of oil to the gear cavities and rotate the gears.
16. Align the guide marks and install the back cover. Make sure the wear plate is still in place. Install the cap screws and tighten to a torque of 200 in. lbs.
17. Add a large amount of oil to both pump ports. Manually rotate the shaft for oil distribution and to make sure the shaft has free movement.

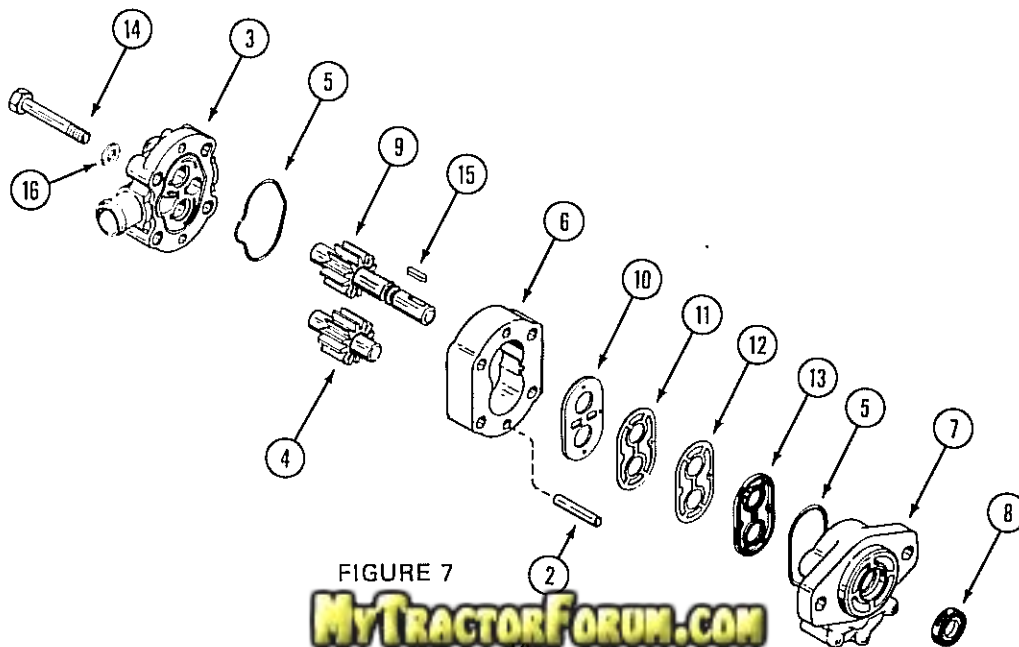

FIGURE 7

CESSNA PUMP

Part Number C25179

For some Models

220 - P.I.N. 9734870 and after
222 - P.I.N. 9736998 and after
224 - P.I.N. 9738335 and after
444 - P.I.N. 9739739 and after
446 - P.I.N. 9742953 and after
448 - All

DISASSEMBLY

1. Remove the key (9) from the shaft.
2. Completely clean the external areas of the pump with a solvent.
3. With the shaft down, put the pump in a vise.
4. Remove the four retainer bolts (15).
5. Put a mark across the pump sections for alignment during assembly.
6. Remove the pump from the vise. Lightly hit the pump shaft against a block of wood. This will separate the front cover (3) or the rear cover (4).
7. To separate the body (6) from the cover, put the drive gear (11) into the bearing. Lightly hit the shaft with a soft hammer.

8. Use a small knife to remove the diaphragm (2) from the front cover.
9. Remove the two springs (1) and two steel balls (13) from the front cover.
10. Lift the backup gasket (8) and the protector gasket (10) from the front cover.
11. Lift the diaphragm seal (7) from the front cover.
12. Remove the shaft seal (5) from the front cover.

INSPECTION

General

1. Completely clean and dry all parts.
2. Use emery cloth to remove small defects from the parts.

Gear Assemblies

1. Check the shaft of the drive gear (11) for a damaged keyway.
2. Check the gear shafts at the bearing and seal contact areas for rough surfaces and wear.
3. Replace the gear assembly if the shaft is worn too much in the bearing contact area. See the Wear Tolerance Chart.

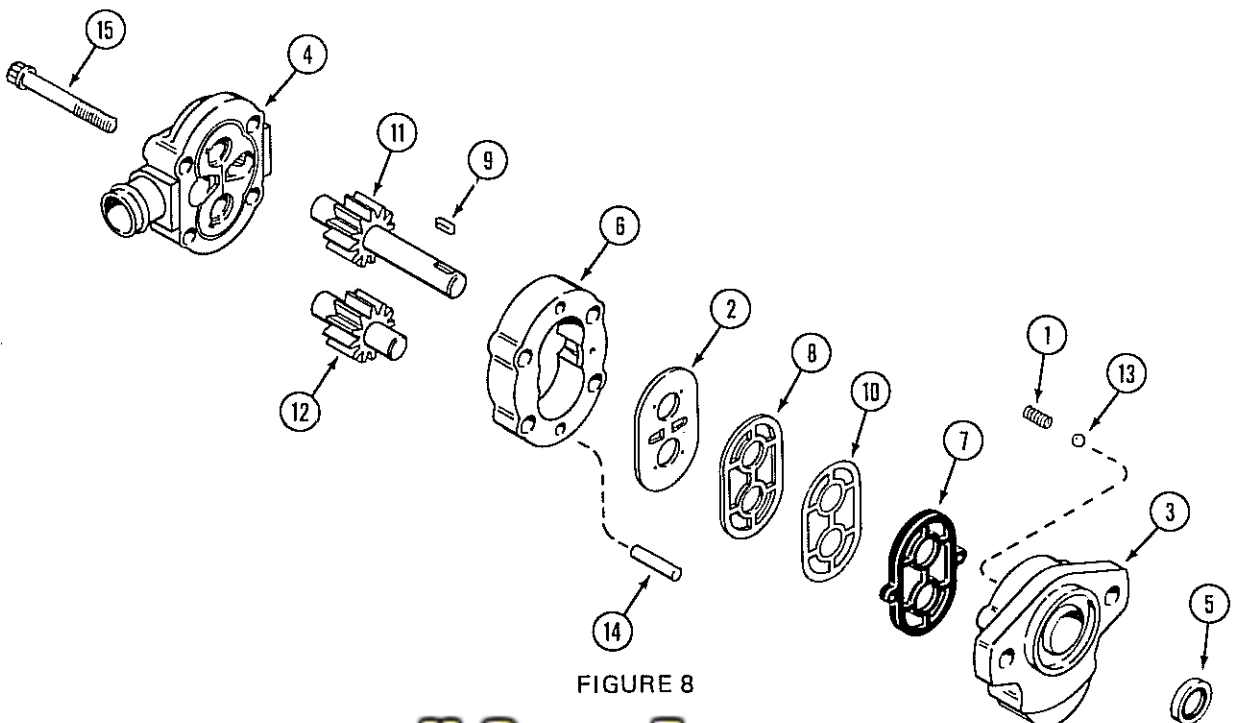

FIGURE 8

4. Check the gear face for scoring and wear.
5. Check the gear width. Replace the gear assembly if worn too much. See the Wear Tolerance Chart.
6. Make sure the snap rings are fully installed in the grooves on either side of the gears.
7. Use emery cloth to remove any sharp edge from the gear teeth.

Front and Rear Covers

1. The oil grooves in the bearings in both covers must be aligned with the dowel pin holes. The grooves must also be 180 degrees apart. Replace the cover if the grooves are not aligned.

2. Check the I.D. of the bearing in both covers. Replace the cover if the wear is too much. See the Wear Chart.
3. The bearings in the front cover must be level with the inside rim of the cover bore.
4. Check for scoring on the face of the back cover. If the wear is too much, replace the cover. See the Wear Tolerance Chart.

Body

1. Check the gear bore for scoring or wear.
2. Replace the body if the gear bore is worn too much. See the Wear Tolerance Chart.

WEAR TOLERANCE CHART

Gear Shaft Diameter	.5605" (14.237 mm) minimum
Gear Width	.803" (20.40 mm) minimum
Cover Bearing I.D.	.5655" (14.364 mm) maximum
Wear Ridge in Rear Cover	.0015" (0.038 mm) maximum
Gear Bore I.D. in Pump Body	1.404" (35.661 mm) maximum

ASSEMBLY

1. Replace the diaphragm, backup gasket, diaphragm seal, protector gasket, shaft seal, steel balls and springs before assembly.
2. Push the diaphragm seal (7) into the grooves in the front cover. The open part of the "V" section must be to the inside. Use a dull tool.

NOTE: Make sure the inner lip of the diaphragm seal does not turn out during assembly.
3. Push the protector gasket (10) and the backup gasket (8) into the diaphragm seal.
4. Put the steel balls (13) into the seats and put the springs (1) over the balls.
5. With the bronze face up, put the diaphragm on the backup gasket. The complete diaphragm must fit inside the rim of the diaphragm seal.
6. Apply oil to the gear assemblies and push into the bearings in the front cover.
7. Install the dowel pins (14) into the body (6).
8. Apply a thin layer of heavy grease to both faces of the body (6). Align the guide marks and install the body on the front cover.
9. Slide the back cover over the gear shafts until the dowel pins fit into the cover. Make sure the guide marks are aligned.
10. Install the retaining bolts (15). Tighten to a torque of 23 to 25 ft. lbs. (31 to 34 Nm).
11. Make sure all sharp edges are removed from the drive gear shaft. Apply a large amount of oil to the shaft and oil seal (5).
12. With a rotating motion, carefully push the seal (5) over the shaft. Lightly hit the seal with a soft hammer to fit the seal fully into the seat.
13. Put a large amount of oil into each pump port. Manually rotate the pump shaft until the shaft turns freely.

BORG WARNER PUMP

Part Numbers C19176, C20025, C20122, C23951

For Some Model 646

DISASSEMBLY

1. Remove the key (15) from the drive shaft.
2. Completely clean all external areas of the pump with a solvent.
3. Put a mark across the pump sections for alignment during assembly.
4. Remove the four bolts (14) that hold the two pump sections together.
5. Put a screwdriver in each slot on opposite sides of the pump body. Carefully separate the two sections.
6. Remove the thrust plate (11) from the pump cover (2).
7. Remove the quad ring (12) from the pump cover (2).
8. Remove the driven gear (10) from the pump body (3).
9. Remove the snap ring (5) from the pump body (3).

10. Remove the wear plate (8) from the pump body (3).
11. Remove the pressure load seals (7) from the wear plate (8).
12. Do not remove the shaft seal (6) unless:
 - a. the seal was leaking
 - b. wear or damage can be seen.

If replacement is necessary, carefully remove the seal to prevent damage to the body bore. Use the following procedure:

1. Remove the seal retaining ring (4).
2. Heat the cover to approximately 250°F (120°C).
- c. Use a small internal puller that will make contact with the steel retainer section of the seal.
- d. Pull the seal straight and even to prevent damage to the body bore.

INSPECTION

1. Completely clean and air dry all parts before inspection. Replace all worn or damaged parts.

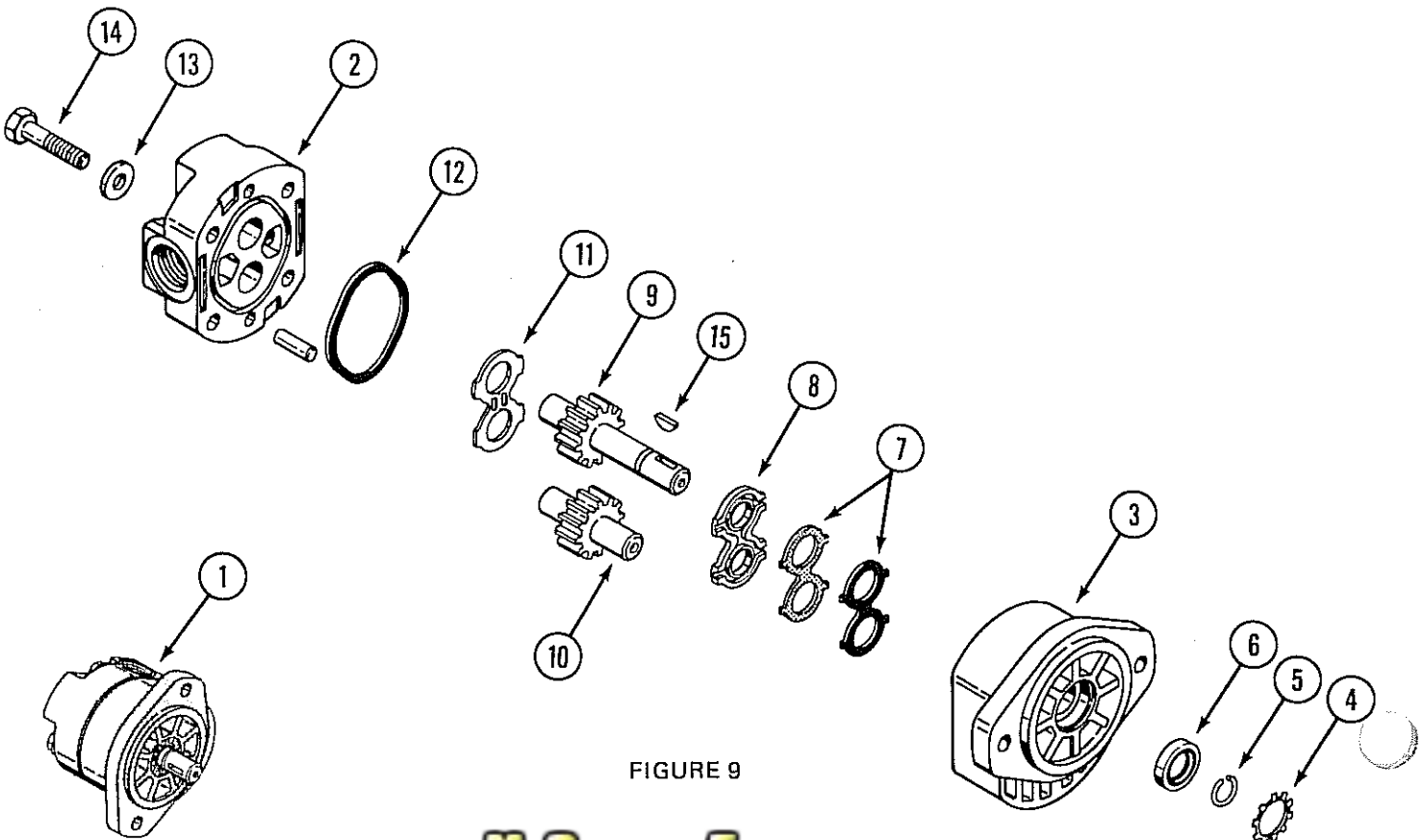

FIGURE 9

2. Check the gear shafts and tooth faces and sides for damage or sharp edges. Small defects can be removed with emery cloth. Do not use emery cloth on the edges of the gear O.D.

3. Check the positions of the bearings in the covers. These bearings are pressed fit and are not replaceable.

The correct position for these bearings are as follows:

a. The split in the bearings must not be more than 1/16" (1.58 mm) from a vertical centerline through both bearings.

b. The bearing in the front cover must be even with the face of the bearing bore.

c. The bearing in the rear cover must be recessed below the face of the bearing bore.

4. Remove any small defects from the faces of the covers and center section. Do not damage any square edges while repairing defects.

a. Put a No. 320 emery cloth on a flat surface.

b. Slide the face on this surface to repair the damage.

Also use this procedure to remove the wear ridge from the surface of the back cover.

5. Replace the seals, gaskets and wear plate each time the pump is disassembled. Do not replace the shaft seal unless this seal is damaged. See Paragraph 12 under disassembly.

3. Install the seal retaining ring (4).

4. Install the pressure load seals (7) into the wear plate (8). The softer seal is installed first.

5. Install the wear plate assembly (8) into the pump body (3). The pressure load seals must be toward the body.

6. Install the drive gear (9) into the pump body (3). If you do not have a seal protector, use the following procedure for installation:

a. Remove all sharp edges from the chamfer, keyway and groove for the snap ring.

b. Apply a layer of oil on the shaft.

c. With a rotating motion, push the shaft through the seal.

d. Install the snap ring (5) on the pump shaft.

7. Install the driven gear (10) in the body (3). The long end of the shaft fits into the body.

8. Install the thrust plate (11) on the gear shafts.

9. Put the quad ring (12) into the groove in the pump cover (2).

10. Align the guide marks and install the cover (2) on the pump body.

11. Install the four retainer bolts (14).

ASSEMBLY

1. Make sure all parts are completely clean. Select a clean area to assemble the pump. Lubricate each part, except the shaft seal, with clean SAE No. 10 before assembly.

2. If a new shaft seal is needed, follow this procedure for installation:

a. Put the pump body (3) on a flat clean surface, with the face down.

b. Put the seal (6) in position with the sealing lip toward the inside of the cover.

c. Use a steel rod with a flat end that is larger than the seal O.D. Hold the rod exactly vertical. Press the seal evenly into the cover bore until the seal is level with the rim.

CESSNA PUMP

Part Number C25287

For Some Model 646

DISASSEMBLY

1. Remove the key (13) from the shaft.
2. Completely clean all external areas of the pump with a solvent.
3. Put a mark across the pump sections for alignment during assembly.
4. With the shaft down, put the pump in a vise.
5. Remove the retainer bolts (1) (2) (3).
6. Remove the pump from the vise. Lightly hit the pump shaft against a block of wood. This will separate the front cover (16) or the rear cover.
7. To separate the body (6) from the cover, put the drive gear into the bearing. Lightly hit the shaft with a soft hammer.
8. Remove the "O" ring (5) from the rear cover.
9. Use a small knife to remove the diaphragm (9) from the front cover.
10. Remove the two springs (14) and the two steel balls (15) from the front cover.

11. Lift the backup gasket (10) and the protector gasket (11) from the front cover.
12. Lift the diaphragm seal (12) from the front cover.
13. Remove the shaft seal (17) from the front cover.

INSPECTION

General

1. Clean and dry all parts.
2. Use emery cloth to remove small defects from the parts.

Gear Assemblies

1. Check the shaft of the drive gear (8) for a damaged keyway.
2. Check the gear shafts at the bearing and seal contact areas for rough surfaces and wear.
3. Replace the gear assembly if the shaft is worn too much in the bearing contact area. See the Wear Chart.
4. Check the gear face for scoring and wear.
5. Check the gear width. Replace the gear assembly if worn too much. See the Wear Chart.

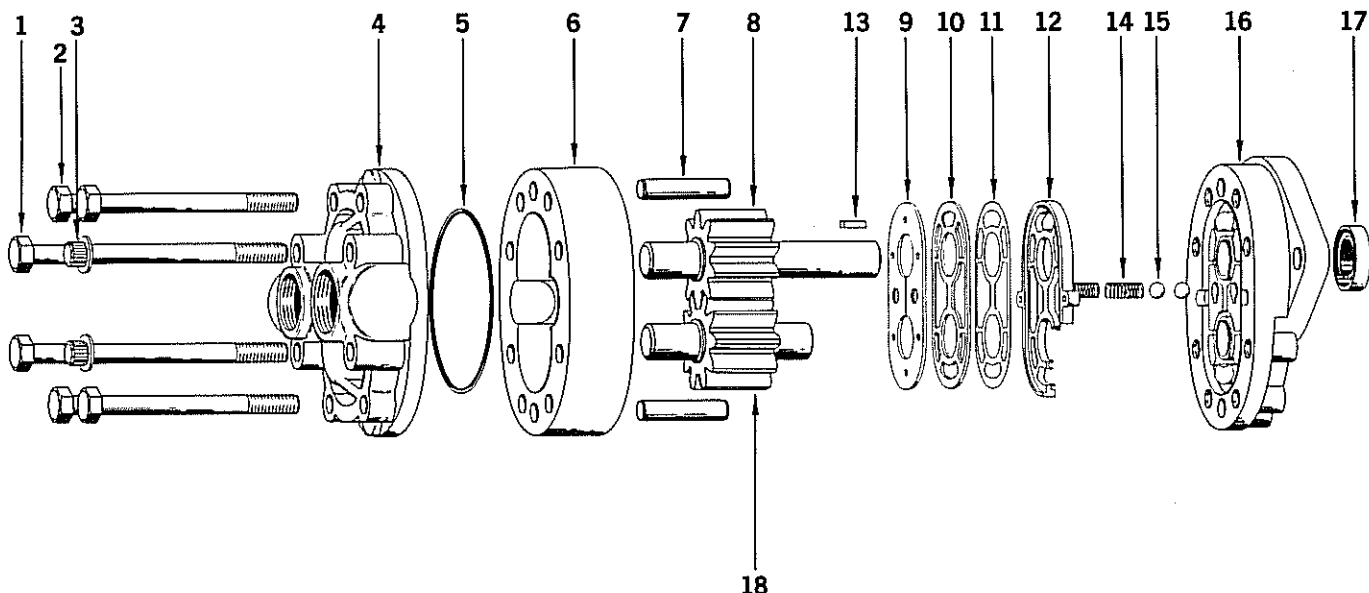

FIGURE 10

WEAR TOLERANCE CHART

Gear Shaft Diameter	.6850" (17.399 mm) minimum
Gear Width	.441" (11.20 mm) minimum
Cover Bearing I.D.	.691" (17.55 mm) maximum
Wear Ridge in the Rear Cover	.0015" (0.038 mm) maximum
Gear Bore I.D. in Pump Body	1.719" (43.66 mm) maximum

6. Make sure the snap rings are fully installed in the grooves on either side of the gears.
7. Use emery cloth to remove any sharp edges from the gear teeth.

Front and Rear Covers

1. The oil grooves in the bearings in both covers must be aligned with the dowel pin holes. The grooves must also be 180 degrees apart. Replace the cover if the grooves are not aligned.
2. Check the I.D. of the bearing in both covers. Replace the cover if the wear is too much. See the Wear Tolerance Chart.
3. The bearings in the front cover must be level with the inside rim of the cover bore.
4. Check for scoring on the face of the back cover. If the wear is too much, replace the cover. See the Wear Tolerance Chart

Body

1. Check the gear bore for scoring or wear.
2. Replace the body if the gear bore is worn too much. See the Wear Tolerance Chart.

ASSEMBLY

1. Always replace the diaphragm, backup gasket, diaphragm seal, protector gasket and shaft seal before assembly.
2. Push the diaphragm seal (12) into the grooves in the front cover. The open part of the "V" section must be to the inside. Use a dull tool.
3. Push the protector gasket (11) and the backup gasket (10) into the diaphragm seal.
4. Put the steel balls (15) into the seats and put the springs (14) over the balls.

5. With the bronze face up, put the diaphragm (9) on the backup gasket. The complete diaphragm must fit inside the rim of the diaphragm seal.

6. Apply oil to the gear assemblies and push into the bearings in the front cover.

7. Install the dowel pins (7) into the body (6).

8. Apply a thin layer of heavy grease to both faces of the body (6). Align the guide marks and install the body on the front cover.

9. Install the "O" ring (5) in the groove in the back cover (4).

10. Slide the back cover over the gear shafts until the dowel pins fit into the cover. Make sure the guide marks are aligned.

11. Install the retaining bolts (1) (2) (3). Tighten to a torque of 23 ft. lb. (31 Nm).

12. Make sure all sharp edges are removed from the drive gear shaft. Apply a large amount of oil to the shaft and the oil seal (17).

13. With a rotating motion, carefully push the seal (17) over the shaft. Lightly hit the seal with a soft hammer to fit the seal completely into the seat.

14. Put a large amount of oil into each pump port. Manually rotate the pump shaft until the shaft turns freely.

