



# Ingersoll

HH34, HH60  
THREE POINT HITCH  
Operator's Manual 8-56392

---

---



QUALITY IN THE AMERICAN TRADITION

Ingersoll Equipment Co., Inc.

Winneconne, Wisconsin 54986-9576





This Safety Alert Symbol Indicates Important Safety Messages In This Manual. When You See This Symbol Carefully Read The Message That Follows and Be Alert To The Possibility Of Personal Injury Or Death

IF THIS MACHINE IS USED BY AN EMPLOYEE OR IS LOANED OR RENTED, MAKE ABSOLUTELY CERTAIN THAT THE OPERATOR(S), PRIOR TO OPERATING:

1. IS INSTRUCTED IN SAFE AND PROPER USE.
2. REVIEWS AND UNDERSTANDS THE MANUAL(S) PERTAINING TO THE MACHINE.

751253



# WARNING

## BEFORE STARTING ENGINE

STUDY OPERATOR'S MANUAL SAFETY MESSAGES  
READ ALL SAFETY SIGNS ON MACHINE  
CLEAR THE AREA OF OTHER PERSONS

## LEARN & PRACTICE SAFE USE OF CONTROLS BEFORE OPERATING

IT IS YOUR RESPONSIBILITY TO UNDERSTAND AND FOLLOW MANUFACTURER'S INSTRUCTIONS ON MACHINE OPERATION, SERVICE, AND TO OBSERVE PERTINENT LAWS AND REGULATIONS. OPERATOR AND SERVICE MANUALS MAY BE OBTAINED FROM YOUR EQUIPMENT DEALER.



The safety messages contained in this manual are to be used together with the safety messages appearing in the tractor operator's manual. Be sure to review both carefully before operating the tractor-attachment combination.

**CAUTION:** Be sure to apply sufficient front counterweight to tractor before operating with rear mounted attachment. Driving tractor with insufficient front counterweight could result in front end tipup and personal injury.

Apply at least 110 lbs. (50 kg) for 3000 series tractors and 140 lbs. (64 kg) for 4000 series tractors.

Heavy attachments and attachments that extend far behind tractor may require more counterweighting. Operate tractor with extreme care and at slow speed to determine if more than the minimum amount of counterweight listed above is required. Add counterweight as necessary to achieve front end stability.

**DO NOT EXCEED HITCH LIFT CAPACITY.**

Remember, a careful operator is always the best insurance against an accident. Always give complete and undivided attention to the job at hand.

**CAUTION:** Only operate controls while seated in the operator's seat.



**CAUTION:** Always lower any rear or front mounted implement to the ground when leaving the tractor unattended.



**CAUTION:** Place the transmission in neutral, set the parking brake and stop the engine before standing between the tractor and attachment when hitching.



**CAUTION:** Hydraulic systems are highly pressurized. Escaping hydraulic oil, even an invisible pinhole leak, can penetrate body tissues causing serious injury. Use a piece of wood or cardboard when looking for leaks - never use the hands or other parts of the body.

Relieve hydraulic pressure before disconnecting circuits. When reassembling, make absolutely certain that all connections are tight.

If injured by hydraulic oil escaping under pressure, see a doctor immediately. Serious complications may arise if medical attention is not given at once.

**IMPORTANT:** Always install new decals whenever the old decals are destroyed, lost, painted over or illegible. When individual parts are replaced that have decals attached, be sure to install a new decal with the new part. Decals are available from your dealer.

## INTRODUCTION

This manual contains recommended operating procedures, safety messages, assembly and mounting instructions. Read this manual carefully before operating your hydraulic 3-Point hitch and sleeve adaptor.

The 3-Point hitch is designed in accordance with ASAE Specification, Category "O" and will accommodate all attachments manufactured to this standard.

The definitions "Right, Left, Front and Rear" as used throughout this manual relate to the tractor and hitch as the operator is seated facing forward in the normal operating position on the tractor.

**NOTE:** Ingersoll Equipment Co., Inc. reserves the right to make improvements in design or changes in specifications at any time without incurring any obligation to install them on units previously sold.

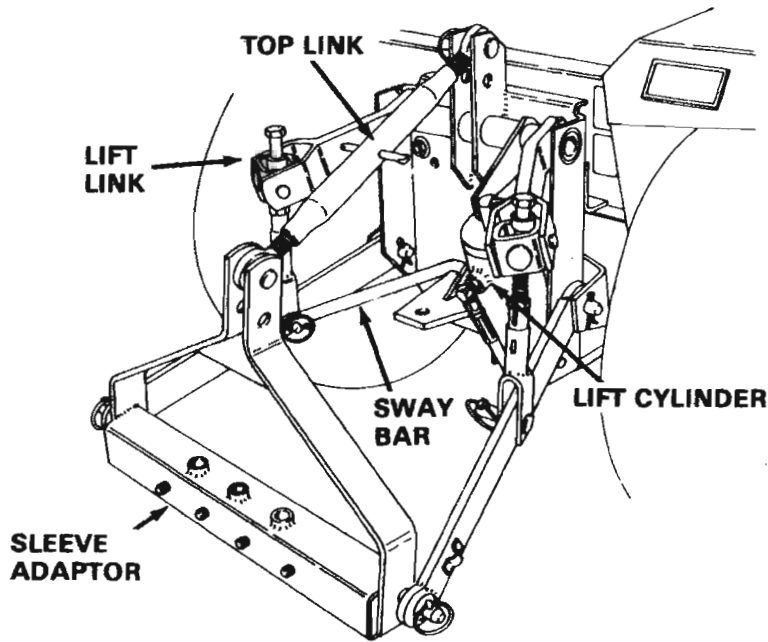

FIGURE 1

### HITCH APPLICATION CHART

HITCH MODEL	TRACTOR MODEL
HH34	3010, 3012, 3014, 3016, 3018 4014, 4016, 4018, 4020, ALL
HH60 or HH34	6018 ALL
F27	HH34, HH60, H26, J26 and LT26 ALL

NOTE: Previous model HH60 hitch is replaced by HH34.

## OPERATING CONTROLS AND ADJUSTMENTS

### 1. Hydraulic Lift

The 3-Point hitch is connected to the tractor hydraulic lift circuit and is equipped with a double-acting hydraulic cylinder.

**RAISE** - Pull the hydraulic lift lever rearward to raise the hitch.

**LOWER** - Push the hydraulic lift lever partway forward to lower the hitch. Down pressure is applied when the hitch is in its lowest position (cylinder fully retracted).

The hydraulic lift centering spring returns the valve to neutral after raising or lowering the hitch.

**FLOAT** - Push the hydraulic lift lever fully forward for the float position. The lever will be held in float by a detent and must be manually returned to neutral.

The float position allows the attachment to follow the ground and is recommended for tilling or plowing.

See your tractor operator's manual for correct use of the tractor controls.



**CAUTION: Only operate controls while seated in the operator's seat.**

### 2. Lift Links

The lift links are threaded and adjustable. Use them to level a mounted attachment or to compensate for the right wheels being in the furrow when plowing.

### 3. Top Link

The top link is threaded and is used to set the fore-aft pitch of the attachment. Two mounting holes for the top link are provided on the hitch frame to aid in setting fore-aft pitch adjustment.

### 4. Sway Bar

The sway bar must be kept anchored to the tow bracket to prevent interference with rear wheels.

## F-27 SLEEVE ADAPTOR

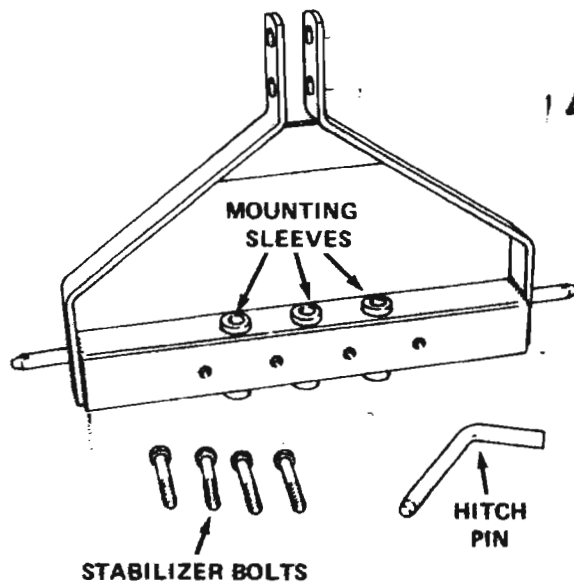

FIGURE 2



**CAUTION: Always lower any rear or front mounted implement to the ground when leaving the tractor unattended.**

The Model F-27 sleeve adaptor converts the 3-Point Hitch to accept sleeve type mounted implements.

1. Four implement stabilizing bolts (Figure 2) are furnished with the sleeve adaptor for use at the four threaded holes. Use these bolts to prevent excessive movement of the attachment. A plow should not be stabilized at this point.
2. There are three mounting sleeves (Figure 2) on the sleeve adaptor to permit centering or offsetting implements. When mounting a plow, be careful to select the mounting position which will allow the share to cut cleanly to the edge of the previous furrow and to the inside of the right rear wheel.

## TIRE CHAINS, WHEEL WEIGHTS AND FRONT END WEIGHTS

The use of tire chains and wheel weights is recommended with the hitch. The extra traction resulting gives the tractor operator increased maneuverability. Front end weights or front weight box is required for stability.

**NOTE:** Front end weight may be added to loader bucket if required.



**CAUTION:** Place the transmission in neutral, set the parking brake and stop the engine before standing between the tractor and attachment when hitching.



Remember, a careful operator is always the best insurance against an accident. Always give complete and undivided attention to the job at hand.

**CAUTION:** Be sure to apply sufficient front counterweight to tractor before operating with rear mounted attachment. Driving tractor with insufficient front counterweight could result in front end tipup and personal injury.

Apply at least 110 lbs. (50 kg) for 3000 series tractors and 140 lbs. (64 kg) for 4000 series tractors.

Heavy attachments and attachments that extend far behind tractor may require more counterweighting. Operate tractor with extreme care and at slow speed to determine if more than the minimum amount of counterweight listed above is required. Add counterweight as necessary to achieve front end stability.

**DO NOT EXCEED HITCH LIFT CAPACITY.**

## MAINTENANCE

1. Grease two fittings on hitch rockshaft daily.
2. Apply oil to pivot pins and attachment mounting pins daily.
3. Do not oil ball joints as this may cause abrasive foreign material to lodge between the ball and retainer.
4. Check for tightness. After first two hours of operation, tighten all bolts which secure hitch to the tractor.
5. A certain amount of oil will normally accumulate at the rod end cap of the lift cylinder during operation. This provides lubrication for the moving parts. There is no requirement for service or repair unless leakage is excessive.
6. Maintain tractor as described in Tractor Operator's Manual.

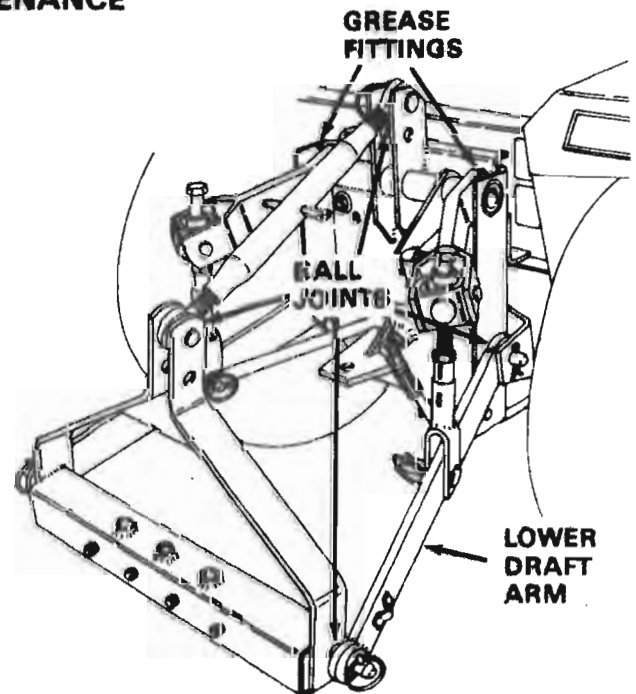

FIGURE 3

## INSTALLATION

1. Identify and inspect 3-Point hitch assembly for completeness before beginning installation. Keep hydraulic hose ends capped to prevent dirt entry.
2. Locate tractor on a clean, level surface such as a concrete garage floor.
3. Remove tow bracket from rear of tractor. Remove the pipe plug from the rear of the transaxle and install the flush plug.

**NOTE:** Leave bolts loose to insure proper alignment during installation. Tighten all bolts after installation is complete.

4. For 3000, 4000 tractors:
  - a. Remove two (2) rear seat support mounting bolts and washers.

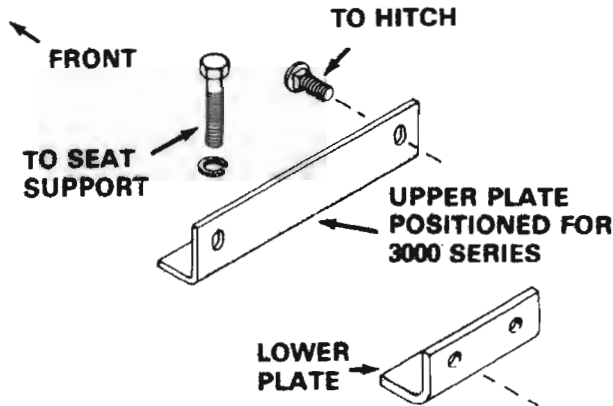

FIGURE 4

- b. Position the upper plate so it extends upward for 3000 series tractors (shown in Figure 7) and downward for 4000 series tractors (not shown). The upper plate should be fastened with the original bolt on the left side and a new 1/4 inch longer bolt (provided) on the right side.
- c. Position the lower plate so it extends under the transaxle casting as shown in Figure 5. Use the new 1-1/4 inch long bolts provided to secure the hitch and lower plate together.

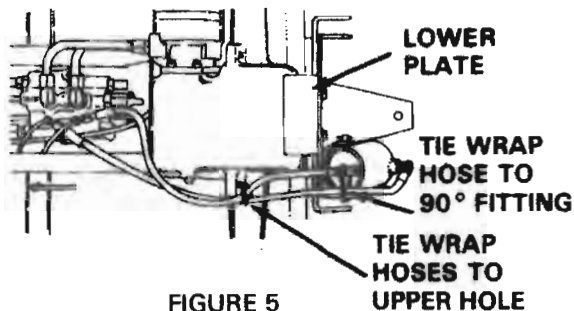

FIGURE 5

5. Install the hitch to the angle plates previously installed on 3000 or 4000 series tractors.

On 6000 series tractors, the hitch mounts directly to the rear of the transaxle housing.

6. Install the lower draft arms to the hitch plate using clevis pins and cotter pins. When correctly installed, the storage clip for the click pins on the draft arms should be to the rear and outboard.

**NOTE:** Loosen swivel nuts on cylinder fittings.

7. a. Install the short hose in the elbow fitting in piston end of 3-Point hitch cylinder. Tighten fitting.
- b. Install the long hose in the rod end of 3-Point hitch cylinder. Make sure this cylinder fitting is fully threaded into cylinder.
- c. Install the cylinder rod end up, elbow toward rear of tractor using the short pin (2) on the rod end and the long pin (3) on the piston end.

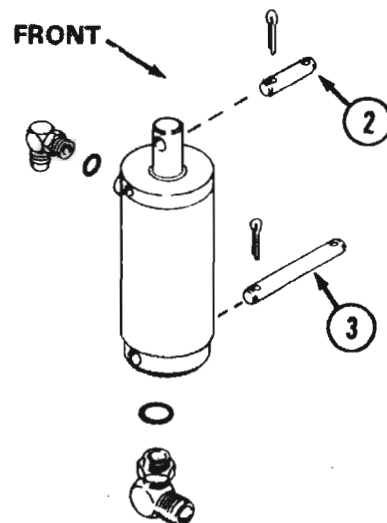

FIGURE 6

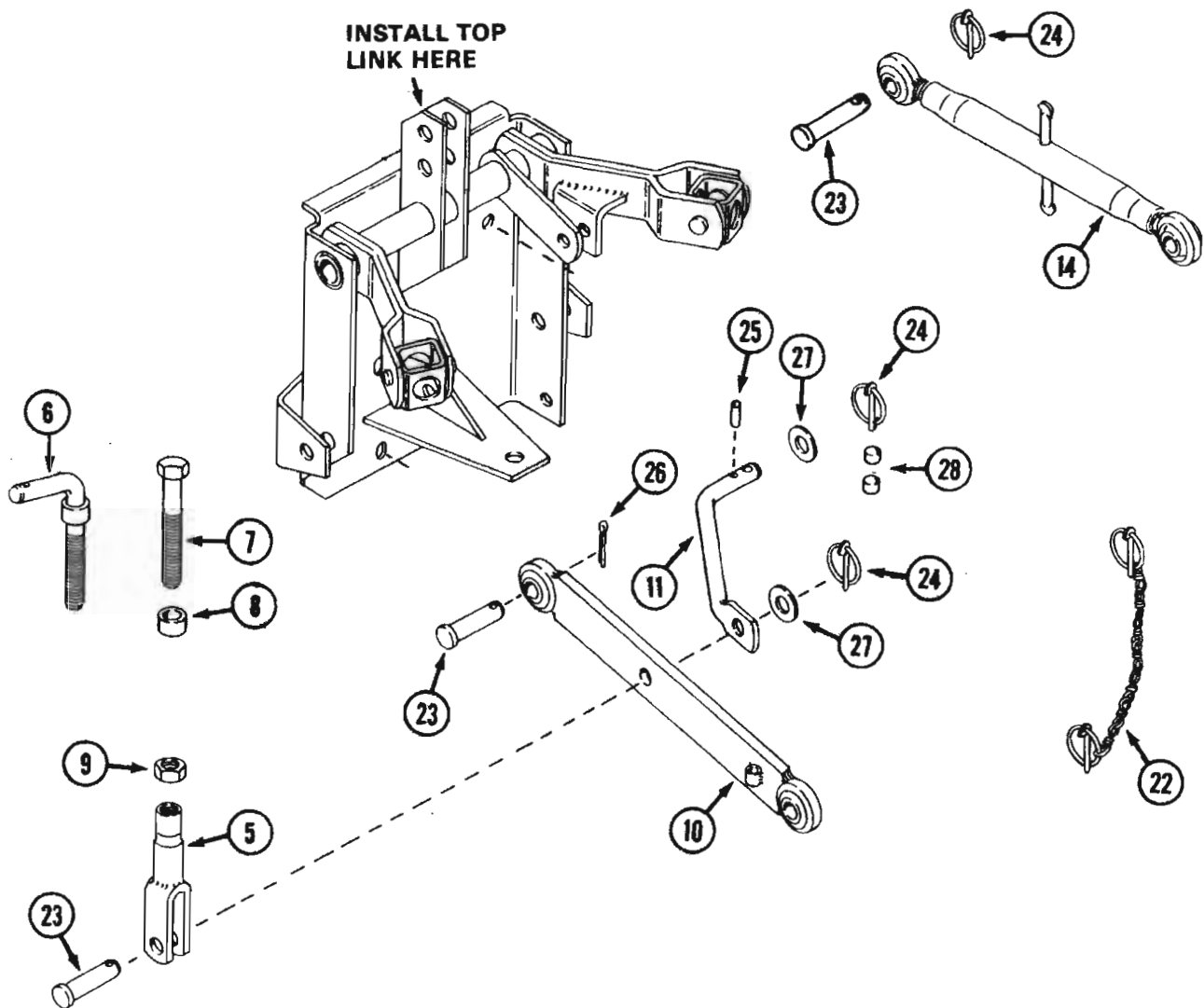

FIGURE 7

See Figure 7

8. Install the bolt (7) spacer (8) through the lift bracket on the lift arm of the rockshaft. Thread jam nut (9) and clevis (5) onto the threaded handle.
9. On early models install the threaded handle (6) through the lift bracket on the right side of the rockshaft. Thread clevis (5) onto the threaded handle.
10. Attach the clevis (5) to the lower draft arms (10) with the clevis pins (23).
11. Place a washer (27) over the drawbar end of the stabilizer (11) and secure the stabilizer between the left clevis and drawbar. Secure with click pins (24). Use the two spacers (28) to hold the click pin up at the drawbar.
12. On early models, the click pin chain assembly (22) should be used on the right side to secure the clevis pin and handle. This will prevent the handle from rotating and losing its adjustment.
13. Adjust the bolt (7) and handle (6) until the ends of the lower draft arms are four inches from the floor.
14. Install the top link (14) to the top hole in the hitch plate.
15. Place the travel and hydraulic lift levers in the neutral position.
16. Remove the belly pan, if equipped, from the tractor and place a clean pan under tractor travel and lift valve.





**CAUTION:** Hydraulic systems are highly pressurized. Escaping hydraulic oil, even an invisible pinhole leak, can penetrate body tissues causing serious injury. Use a piece of wood or cardboard when looking for leaks - never use the hands or other parts of the body.

Relieve hydraulic pressure before disconnecting circuits. When reassembling, make absolutely certain that all connections are tight.

If injured by hydraulic oil escaping under pressure, see a doctor immediately. Serious complications may arise if medical attention is not given at once.

17. On 3000, 4000 series tractors, disconnect the hydraulic lift lines from the travel and lift valve. On 6000 series tractors, remove the caps from the 90° fittings on the lift ports.
18. Loosely connect the hydraulic lift lines to the tee fittings on 3000, 4000 tractors.

For 3000, 4000 tractors before PIN 14169364 turn the tee fittings onto the lift port straight fittings of the valve. With the fittings facing rearward as shown in Figure 8 tighten the swivels against the lift port straight fittings. Tighten tubes.

For 3000, 4000 tractors PIN 14169364 and after, install tee fittings and lines as shown in Figure 9.

19. Route the hose from the piston end of the cylinder under transmission and install to rear fitting in travel and lift valve.

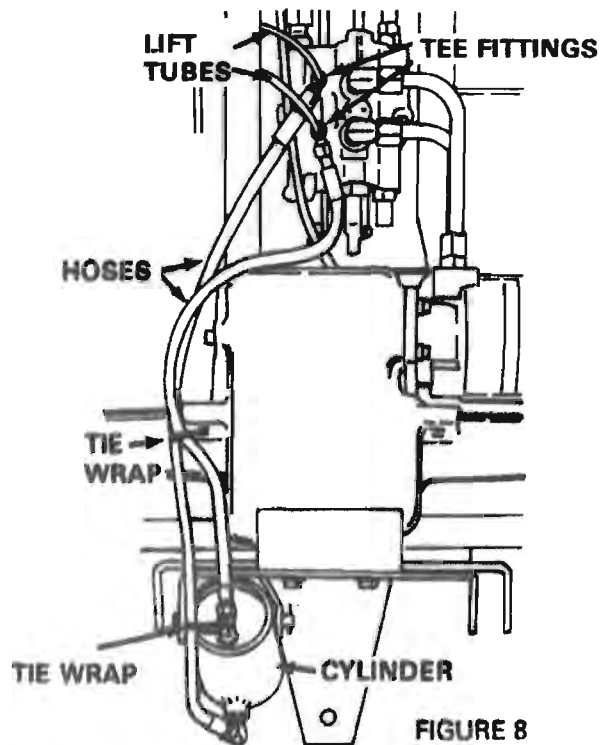

FIGURE 8

20. Route hose from the rod end of the cylinder down under the transmission and install to front fitting in travel and lift valve.

Use plastic ties to fasten the hoses to the tractor frame.

21. Check and tighten all connections and swivel nuts as required.
22. Start the tractor and operate the cylinder to full open and closed positions several times to expel all air from the system. Shut off the tractor and check for oil leaks at all connections. Check the oil level in the reservoir and add if necessary to bring to proper level as described in tractor operator's manual.
23. Tire pressure should be checked and adjusted, if necessary, in accordance with the tractor operator's manual.

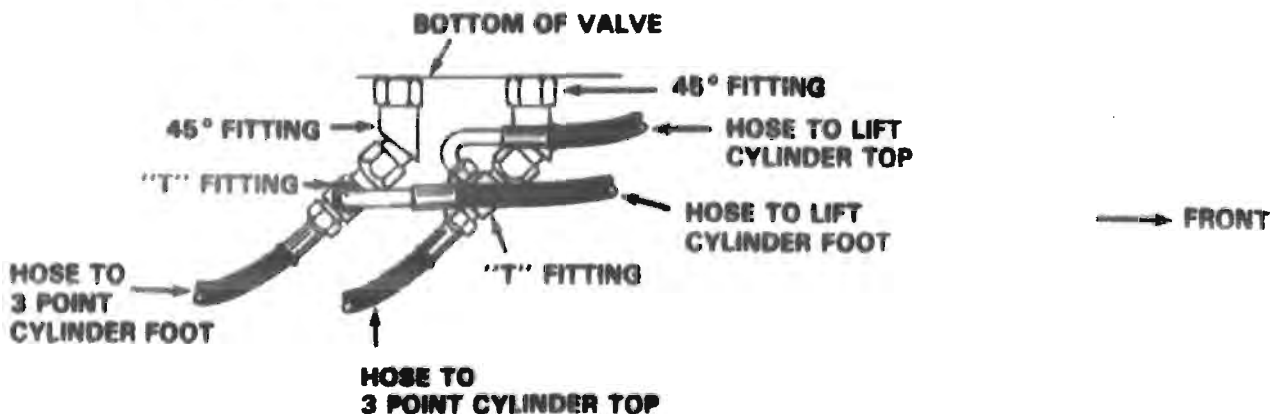

FIGURE 9