



CASE DRAIN KIT INSTALLATION INSTRUCTIONS

This instruction manual contains case drain kit installation instructions for the following model tractors and associated case drain kits:

KIT NO.		PAGE NO.																		
C37449	3000/4000 Series tractor identified below with fender mounted Hyd. PTO valve	2																		
	<table><thead><tr><th>MODEL NO.</th><th>PRODUCT IDENTIFICATION NO.</th></tr></thead><tbody><tr><td>3012</td><td>14136264 & UP</td></tr><tr><td>3014</td><td>14137123 & UP</td></tr><tr><td>3016</td><td>14147605 & UP</td></tr><tr><td>3018</td><td>14138934 & UP</td></tr><tr><td>3020</td><td>14133226 & UP</td></tr><tr><td>4016</td><td>14139867 & UP</td></tr><tr><td>4018</td><td>14141095 & UP</td></tr><tr><td>4020</td><td>14142136 & UP</td></tr></tbody></table>	MODEL NO.	PRODUCT IDENTIFICATION NO.	3012	14136264 & UP	3014	14137123 & UP	3016	14147605 & UP	3018	14138934 & UP	3020	14133226 & UP	4016	14139867 & UP	4018	14141095 & UP	4020	14142136 & UP	
MODEL NO.	PRODUCT IDENTIFICATION NO.																			
3012	14136264 & UP																			
3014	14137123 & UP																			
3016	14147605 & UP																			
3018	14138934 & UP																			
3020	14133226 & UP																			
4016	14139867 & UP																			
4018	14141095 & UP																			
4020	14142136 & UP																			
C37450	3000/4000 Series Tractors prior to PINS identified above with fender mounted Hyd. PTO	4																		
C37451	200/400 Series Tractors	6																		
C37452	6018 Loader Tractors	8																		

Refer to appropriate pages for specific installation instructions.

CASE DRAIN KIT C37449

MODELS 3000/4000 SERIES TRACTORS

This kit provides a quick coupler connection location at the tractor for hydraulic attachments which require a case drain connection. Components in this package are for the following tractors with fender mounted PTO valve.

MODEL NO.	PRODUCT IDENTIFICATION NO.
3012	14136264 & UP
3014	14137123 & UP
3016	14147605 & UP
3018	14138934 & UP
3020	14133226 & UP
4016	14139867 & UP
4018	14141095 & UP
4020	14142136 & UP

1. Route the drain hose as shown in Figure 2 from travel control valve to PTO valve with flared-fitting end of hose at travel valve. Route hose over travel motor and tie wrap to PTO hoses or tubes to avoid contact with transaxle shift lever.
2. Apply thread sealant to rear end of hose, install dust cap and male quick coupler to hose.
3. Remove lower bolt securing PTO valve to mounting bracket.
4. Secure case drain hose to PTO valve bracket using 1/4"-20 x 1-3/4" bolt, hose clamp, flat-washer, original lockwasher and nut.
5. The travel control valve contains a case drain port located on the R.H. side of the valve as shown in Figure 1. If an elbow or tee fitting is already installed in this port, remove cap from fitting and connect case drain hose to fitting.

If a fitting was not installed in the travel valve, perform steps below:

- a. Drain the hydraulic system by removing plug from case drain port on R.H. side of travel valve.
- b. Install 90° fitting provided in kit into port on travel valve and tighten so that elbow faces rear of tractor.
- c. Connect case drain hose to 90° fitting and tighten.
- d. After all connections are tight, refill hydraulic system.

IMPORTANT: A matching female coupler is provided with this kit to be used on the case drain hose from the hydraulic attachment. To insure oil flow thru connected couplers, always be sure brands of couplers match. Restricted case flow from attachment hydraulic motor can result in damage to motor or seals.

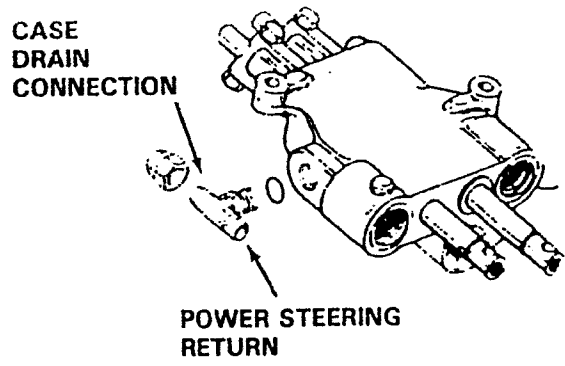

FIGURE 1 - Power Steering Model Shown

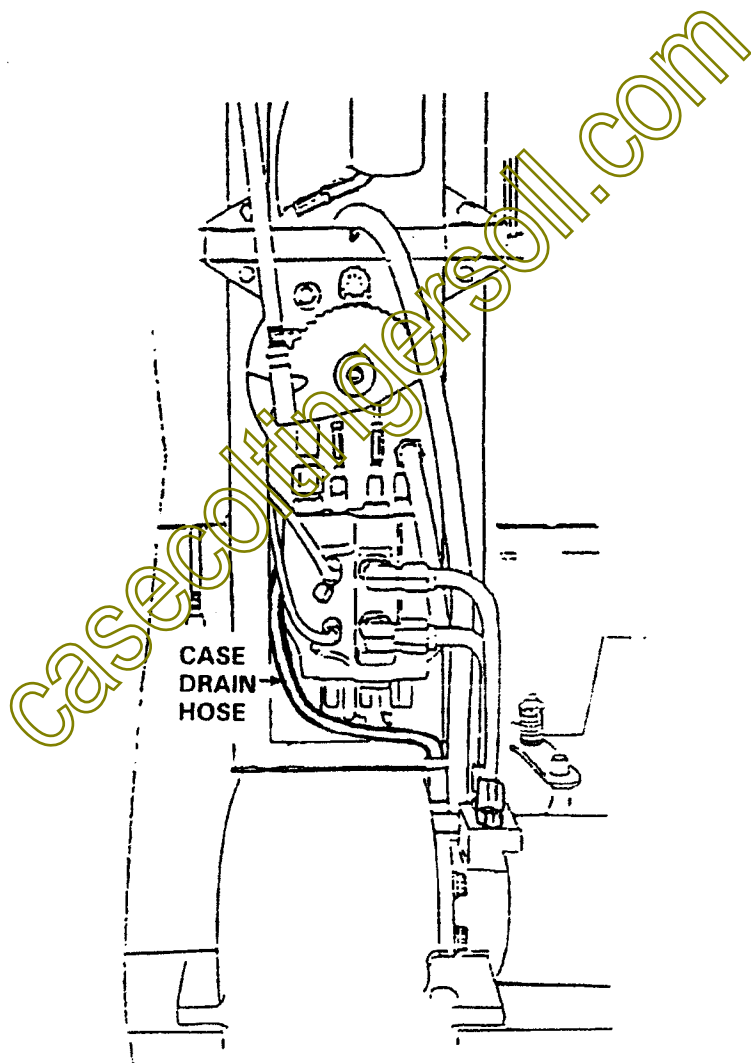

FIGURE 2

CASE DRAIN KIT C37450

MODELS 3000/4000 SERIES TRACTORS

This kit provides a quick coupler connection location at the tractor for hydraulic attachments which require a case drain connection. Components in this package are for the following tractors:

MODEL NO.	PRIOR TO PIN NO.
3012	14136264
3014	14137123
3016	14147605
3018	14138934
3020	14133226
4016	14139867
4018	14141095
4020	14142136

1. Drain the hydraulic system.
2. Remove the rear and right side tower access panels.
3. Remove the original "return oil" tube between the tractor travel control valve and the oil cooler. Remove hose from oil cooler.

Closely observe the location of this tube before removal since the new tube and hose must be installed in the same manner.

4. Install the new "return oil" tube and hose between the tractor travel control valve and the oil cooler. Use original hose clamps and tighten.
5. Route the drain hose as shown in Figure 3 and 4.
 - a. Route flare end of hose up into the control tower and follow along the PTO hoses to the PTO valve.
 - b. Place hose over the travel motor and tie-wrap to PTO hoses or tubes to avoid contact with transaxle shift lever.
6. Connect this hose to the nipple on the return oil tube as shown in Figure 3 using a 45° fitting.
7. Apply thread sealant to rear end of hose, install dust cap and male quick coupler to hose.
8. Remove lower bolt securing PTO valve to mounting bracket.
9. Secure case drain hose to PTO valve bracket using 1/4"-20 x 1-3/4" bolt, hose clamp, flat-washer, original lockwasher and nut.
10. After all connections are tight, refill hydraulic system. Reinstall access panels.

IMPORTANT: A matching female coupler is provided with this kit to be used on the case drain hose from the hydraulic attachment. To ensure oil flow thru connected couplers, always be sure brands of couplers match. Restricted case flow from attachment hydraulic motor can result in damage to motor or seals.

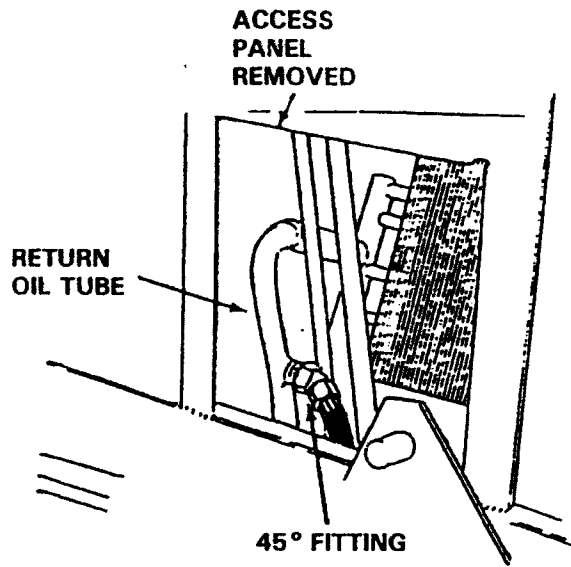

FIGURE 3

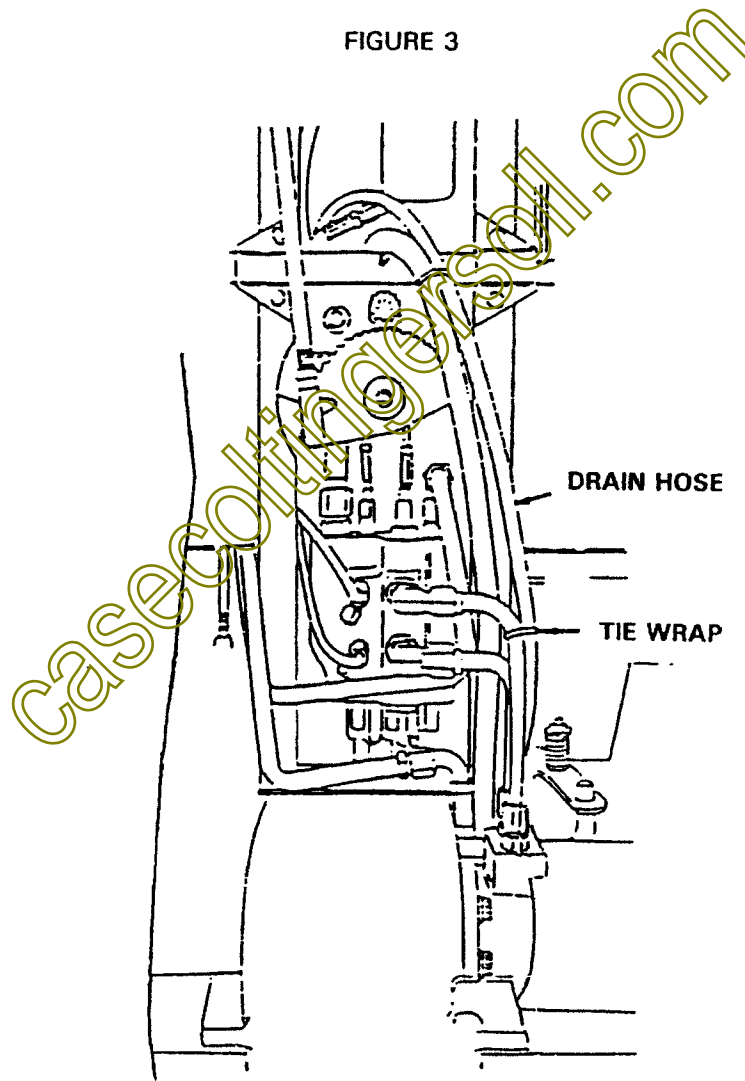

FIGURE 4 - Bottom View

CASE DRAIN KIT C37451

MODELS 200/400 SERIES TRACTORS

This kit provides a quick coupler connection location at the tractor for hydraulic attachments which require a case drain connection.

1. Drain hydraulic oil.
2. Remove short length of hose between the heat exchanger and travel valve to heat exchanger tube. Discard hose clamps.
3. Cut two 4" long hoses from length of hose provided in kit.
4. Install tee fitting, both new 4" long hoses and (4) hose clamps as shown in Figure 5.

NOTE: For 220, 222, 224, and 444 tractors: position tee fitting so male connection is pointing up and toward the engine as shown. For 226, 446, and 448 tractors: position tee fitting so male connection is pointing down and toward the engine.

Position clamps to prevent interference when the hood is closed.

** Tractors prior to the listed PIN's require a P/N C26182 valve-to-heat exchanger tube (Use P/N C26181 if flow control is mounted on tractor).

220	Prior to PIN 9780384	444	Prior to PIN 9784992
222	9782110	446	9787599
224	9783579	448	9789840

4. Install 90° fitting on tee fitting and point it rearward as shown in figure 5.
5. Route drain hose as shown in Figures 5 and 6. Flared fitting on hose toward tee fitting.
 - a. Route hose above steering sector gear bracket and between the right hand frame rail and both the PTO rod and implement lift cylinder hoses.
 - b. Tie-wrap hose to tube (travel valve-to-heat exchanger) close to the PTO rod to avoid hose contact with rod.
 - c. Place hose over travel motor and tie-wrap to PTO hoses or tubes to avoid contact with transaxle shift lever.
 - d. Apply thread sealant to rear end of hose, install dust cap and male quick coupler to hose.
 - e. Attach flared fitting end of hose to 90° fitting as shown in figure 5.
6. Remove lower bolt securing PTO valve to mounting bracket.
7. Secure case drain hose to PTO valve bracket using 1/4"-20 x 1-3/4" bolt, hose clamp, flat-washer, original lockwasher and nut.

NOTE: If PTO valve is mounted with 3/8" x 3/4" bolts, remove lower rear bolt. Install hose clamp provided with kit, re-install 3/8" bolt and lockwasher.

8. After all connections are tight, refill hydraulic system.

IMPORTANT: A matching female coupler is provided with this kit to be used on the case drain hose from the hydraulic attachment. To ensure oil flow thru connected couplers, always be sure brands of couplers match. Restricted case flow from attachment hydraulic motor can result in damage to motor or seals.

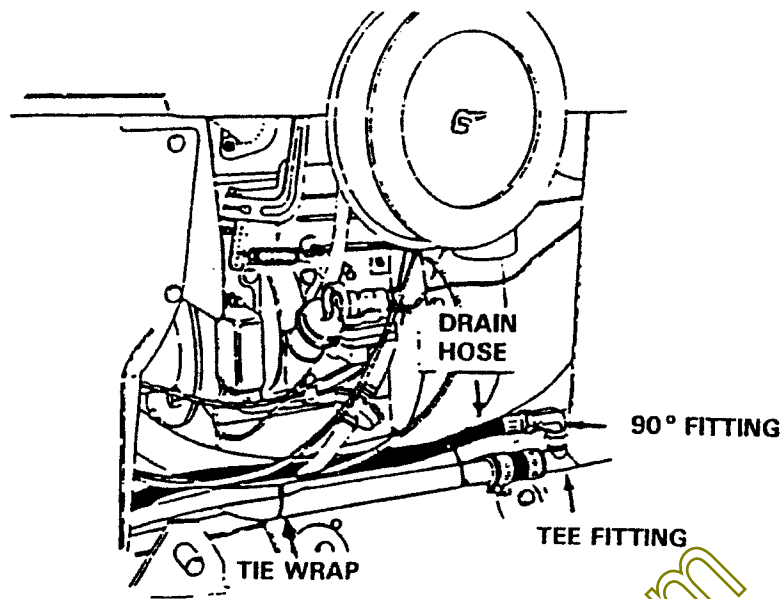

FIGURE 5 Model 220 Shown

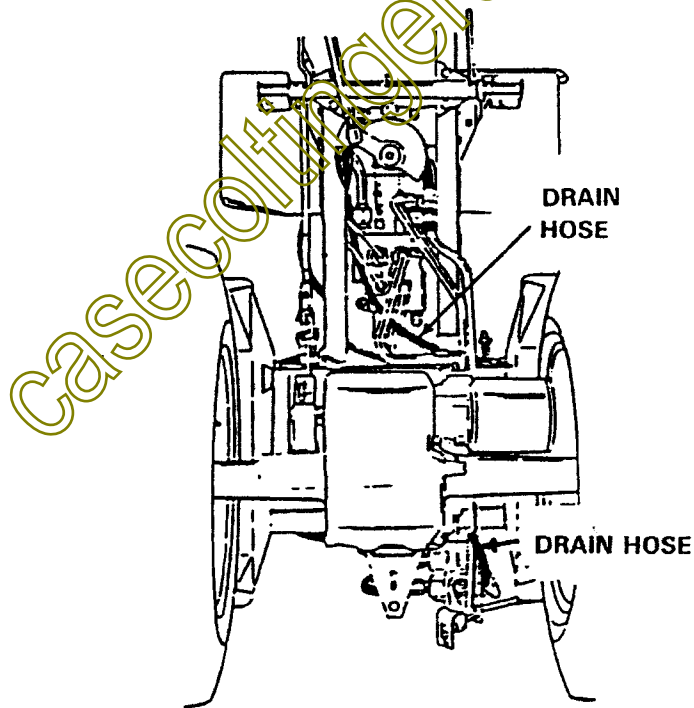

FIGURE 6 Bottom View

CASE DRAIN KIT C37452

MODEL 6018 TRACTORS

This kit provides a quick coupler connection location at the tractor for hydraulic attachments which require a case drain connection.

1. Drain hydraulic oil.
2. Loosen clamps and remove hose between hydraulic filter and oil cooler. (Figure 7)
3. Measure 4.0'' (102mm) from rear end of hose and mark this position. Cut hose at mark and insert tee fitting at this location between both ends of hose. Position new clamps onto hoses at tee but do not tighten at this time. (Figure 7)
4. Reinstall hydraulic hose with tee, using original clamps at oil filter and oil cooler. Leave clamps loose.
5. Route drain hose from tee fitting to PTO valve located on R.H. fender. Flare end of hose toward tee fitting.
 - a. Carefully route hose from L.H. side of frame past travel control linkage located between frame rails. (Figure 8)
 - b. Route hose along PTO valve supply tube so it passes over R.H. axle.
 - c. Use tie wraps to secure hose away from sharp edges and moving linkages.
6. Thread 90° fitting on flared end of drain hose. Thread 90° fitting onto tee fitting. Position tee fitting in hoses so that drain hose and fittings clear engine and other components. Tighten all clamps and fittings.
7. Apply thread sealant to rear end of hose and install dust cap and male quick coupler to hose.
8. Position case drain hose against top hydraulic line connected to PTO valve and secure with tie wrap.
9. After all connections are tight, refill hydraulic system.

IMPORTANT: A matching female coupler is provided with this kit to be used on the case drain hose from the hydraulic attachment. To ensure oil flow thru connected couplers, always be sure brands of couplers match. Restricted case flow from attachment hydraulic motor can result in damage to motor or seals.

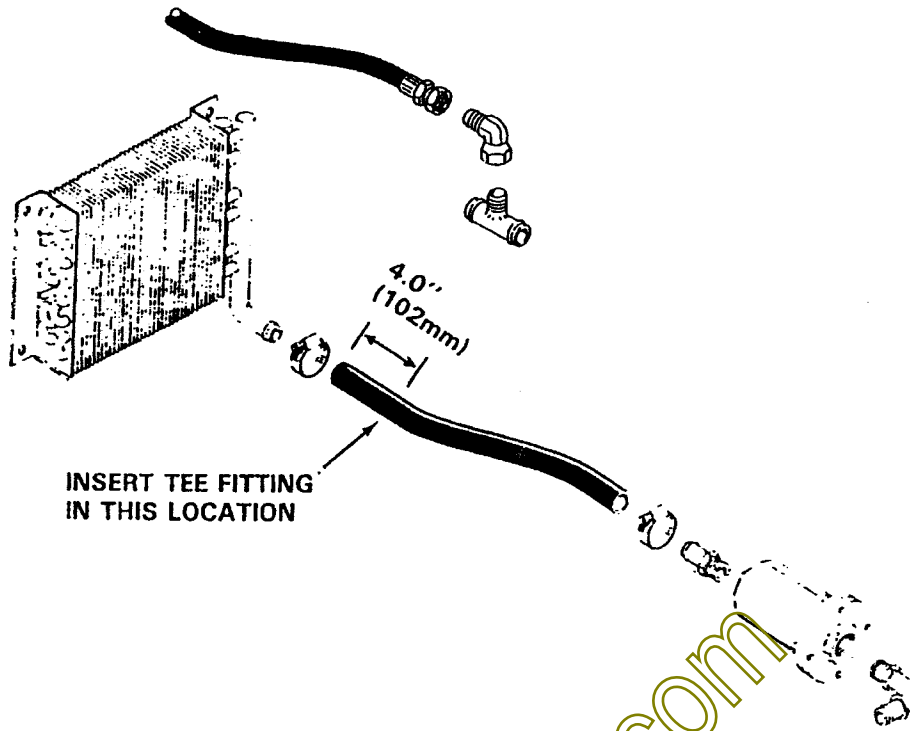

FIGURE 7 - Tee Installation Location

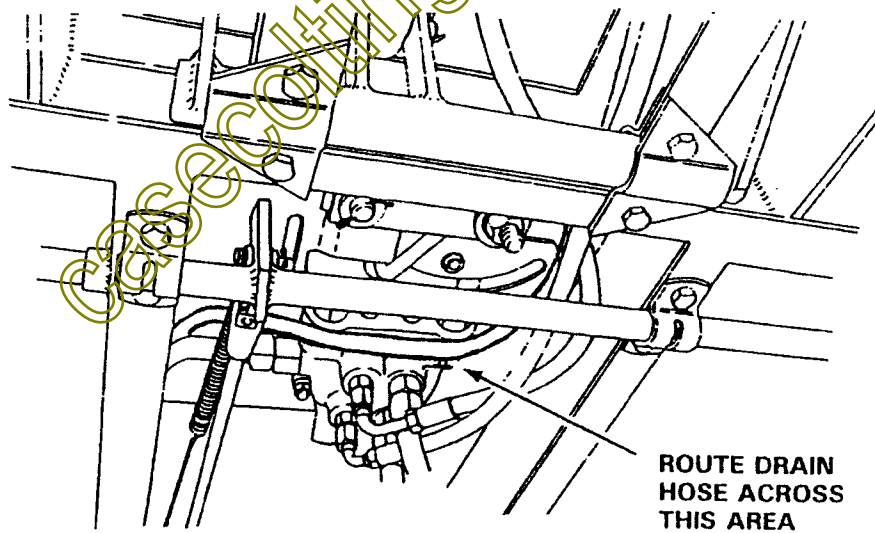

FIGURE 8