

Ingersoll

**DUMP CART
G60, F60
Operator's Manual 9-51741**

casecoltingersoll.com



Ingersoll . . . the new name to say for Case garden tractors.

Ingersoll Equipment Co., Inc. Winneconne, Wisconsin 54986-9576



This Safety Alert Symbol Indicates Important Safety Messages In This Manual When You See This Symbol Carefully Read The Message That Follows and Be Alert To The Possibility Of Personal Injury Or Death

IF THIS MACHINE IS USED BY AN EMPLOYEE OR IS LOANED OR RENTED, MAKE ABSOLUTELY CERTAIN THAT THE OPERATOR(S), PRIOR TO OPERATING:

- 1. IS INSTRUCTED IN SAFE AND PROPER USE.**
- 2. REVIEWS AND UNDERSTANDS THE MANUAL(S) PERTAINING TO THE MACHINE.**

751253



WARNING

BEFORE STARTING ENGINE

**STUDY OPERATOR'S MANUAL SAFETY MESSAGES
READ ALL SAFETY SIGNS ON MACHINE
CLEAR THE AREA OF OTHER PERSONS**

**LEARN & PRACTICE SAFE USE OF
CONTROLS BEFORE OPERATING**

IT IS YOUR RESPONSIBILITY TO UNDERSTAND AND FOLLOW MANUFACTURER'S INSTRUCTIONS ON MACHINE OPERATION, SERVICE, AND TO OBSERVE PERTINENT LAWS AND REGULATIONS. OPERATOR AND SERVICE MANUALS MAY BE OBTAINED FROM YOUR EQUIPMENT DEALER.

PULLING TRAILERS AND CARTS

- WARNING:** Your ability to:
- Stop the tractor
 - Steer the tractor
 - Maintain complete control of the tractor
 - Maintain a safe, uniform speed when descending an incline

will change when pulling a trailer or cart with a load.

If you pull a load that is too heavy for your tractor, you will probably lose control of your tractor and have an accident.

Make sure the load you are pulling is not too heavy for your tractor.

To minimize the possibility of accidents when pulling loads with your tractor, obey a combination of rules, practices and use good common sense.

These Rules and Practices include:

- Reading, understanding, and obeying all written safety messages appearing on decals on the machine and in operator's manual.
- Learning from your operator's manual and carefully from **EXPERIENCE** how to operate your tractor correctly when pulling a trailer or cart. Know your tractor's limitations.
- Learning to expect changes in operating conditions resulting from pulling trailers and carts with different loads.
- Learn what size loads you can safely transport with your tractor, knowing the way your tractor is equipped when driving on specific terrain.

The following factors concerning the load you are pulling affect operating conditions:

- The weight of the load.
- The rolling resistance of the pulled trailer or cart (usually related to tire size and air pressure).
- The angle at which the tongue of the trailer or cart meets the tractor draw bar.
- The weight of the tongue of the trailer or cart on the tractor draw bar.
- The weight of your tractor.
- The way your tractor is equipped (mounted attachments, wheel weights, tire chains, etc.).

- The speed you are traveling.
- The slope of the terrain and whether the load is being carried downhill or uphill.
- The tractive conditions of the terrain (grass, loose gravel, snow or ice, etc.).
- Changing conditions, changing slope, changing traction conditions, shifting load in trailer or cart.

As a general rule, you should attempt to pull loads less than the weight of your tractor. The factors listed above will require you to even further reduce the load that you can pull safely.

Learn how much weight you can pull by practicing on firm level ground. Reduce the load and speed when traveling on slopes or on poor tractive conditions.

The load you pull must not be heavy enough to cause the tractor wheels to skid when starting, stopping or turning a corner.

The operator is the sole judge as to the amount of load that can be safely pulled in a trailer or cart. If in doubt, that the load can be safely pulled, reduce the load or find another means to move it.

GEAR DRIVE TRACTORS

Do not disengage the transmission drive when moving with a loaded trailer or cart unless stopping. Select a gear low enough to maintain complete control of the towed trailer or cart at all times. Select this gear before beginning to go down a slope.

HYDRAULIC DRIVE TRACTORS

Place the 2-speed transaxle in low range whenever pulling a loaded trailer or cart.

Make sure that the retard position of your travel control is properly engaged before going down a slope.

The optional holding valve (available from your dealer) is recommended if you pull loaded trailers or carts.

Your tractor is equipped with a differential brake. If tractive conditions are poor and/or the load you are pulling is too great and the brakes are applied, one rear wheel will skid in the forward direction, the other rear wheel will skid in the reverse direction. If this occurs, stop the tractor immediately and reduce the load and/or increase your tractor's tractive ability by adding rear wheel weights and/or tire chains.

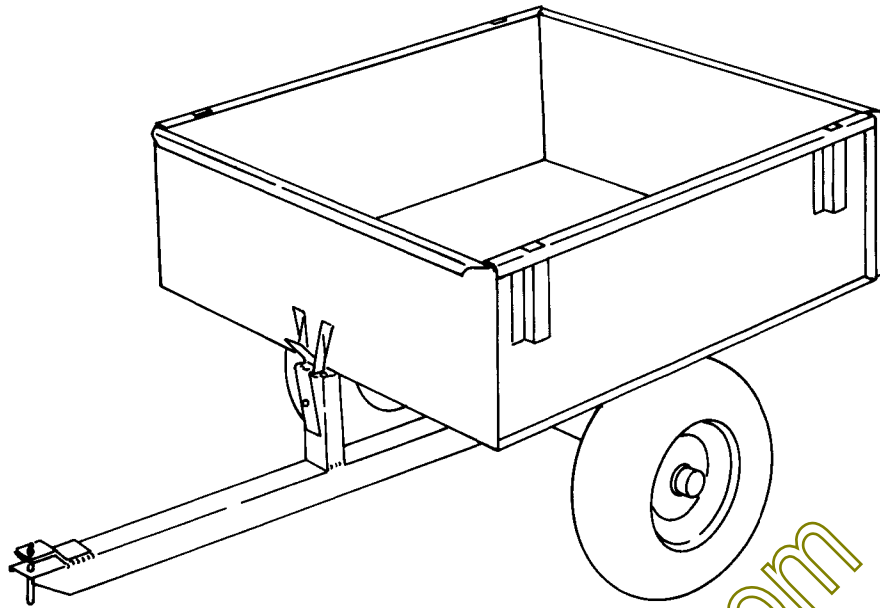

FIGURE 1 Dump Cart -- Assembled

INTRODUCTION

The Dump Cart offers several design features which include:

1. Eight cubic foot (.23 m³) box capacity.
2. Axle support extends across full width of the box providing full 1000 pound (454 kg) test load rating.
3. The inside surfaces of the box are completely free of bolt heads or other protrusions which permits unobstructed use of shovels and scrapers for easy cleanout.
4. The box dumps at a 40° angle allowing fast, clean and positive unloading.
5. Side stake pockets are provided to allow the installation of Model E65 side rack kit, available from your dealer.
6. Angled channel tail gate slide for easy removal and tight closure.
7. A tail gate designed so that the smooth side is always toward the inside of the box for easy removal when loaded.
8. A spring loaded latch for positive locking action after completion of dump.
9. Folded top edges that form a rub rail and reinforce the box sides.
10. Some F-60 Dump Carts have a two-piece tongue.

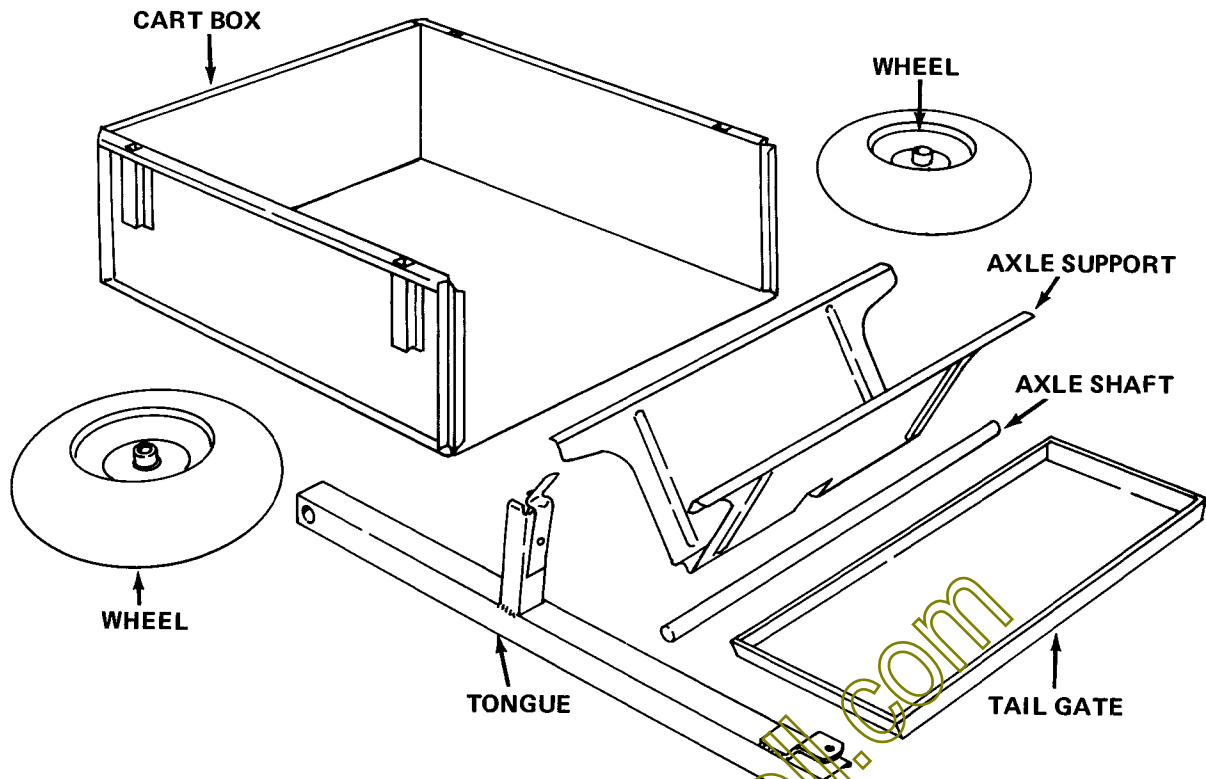

FIGURE 2 Dump Cart - Disassembled

ASSEMBLY

1. Put the cart box upside down.

Position the axle support over the cart box and slip one edge of the axle support into the slot on the cart box.

2. See Figure 3. The axle support is symmetrical and can be installed with either side facing forward.

Squeeze the axle support together slightly, push down and slip the other edge into the other slot.

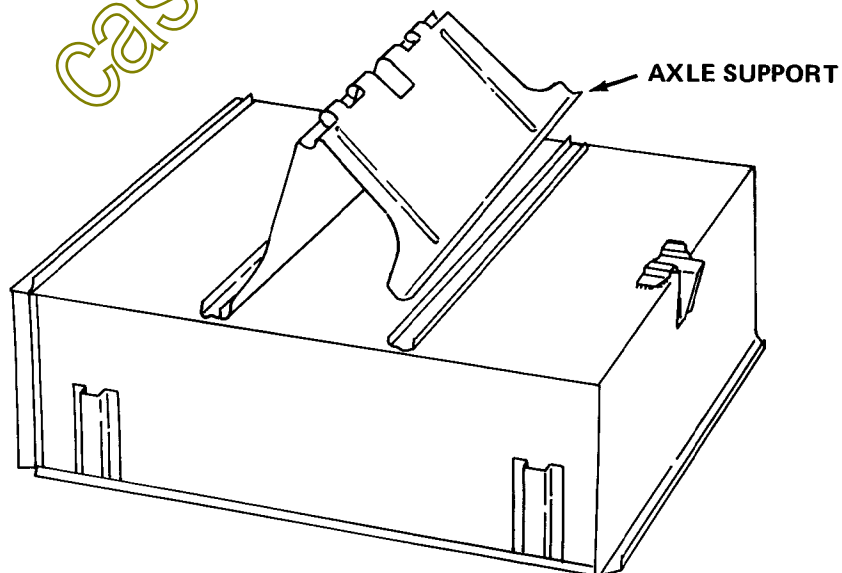

FIGURE 3

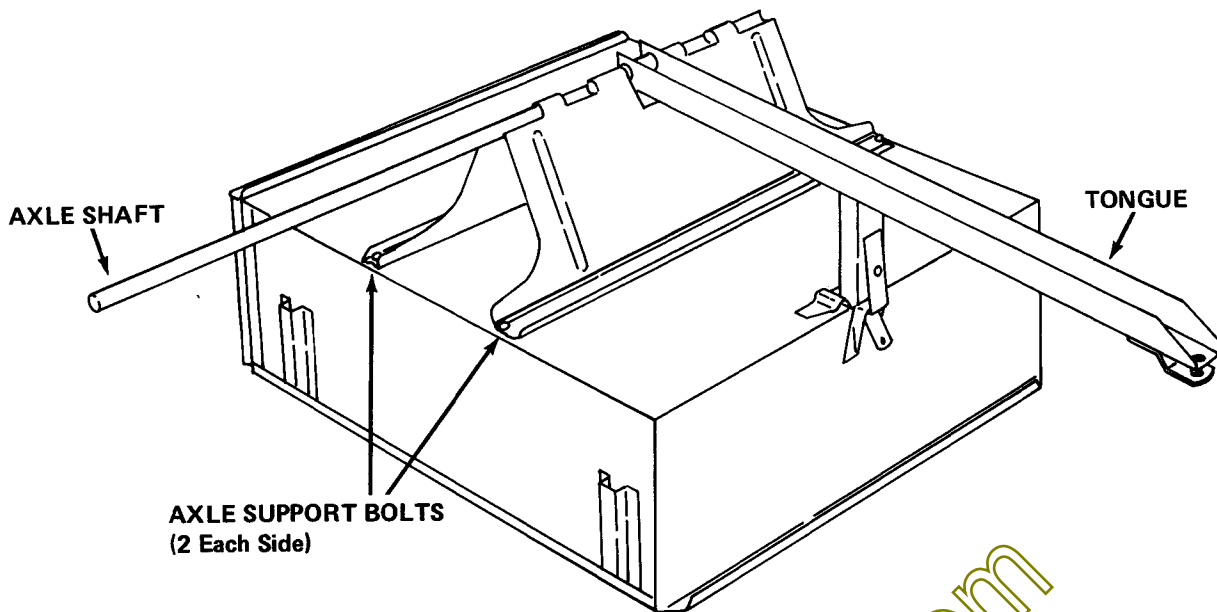

FIGURE 4

3. See Figure 4. Install and tighten the four bolts to hold the axle support in position.
4. Put the tongue in the center slot of the axle support.
5. Apply a light coating of grease or oil to the axle shaft.
6. Slide the axle shaft through the axle support and tongue.

IMPORTANT: Put a block of wood against the shaft if it is necessary to use a hammer.

7. Install one flat washer, the wheel with the valve stem to the outside, one flat washer and cotter pin. Repeat for other wheel.
8. Put the cart upright and slide the tail gate into position.

OPERATION AND ADJUSTMENT

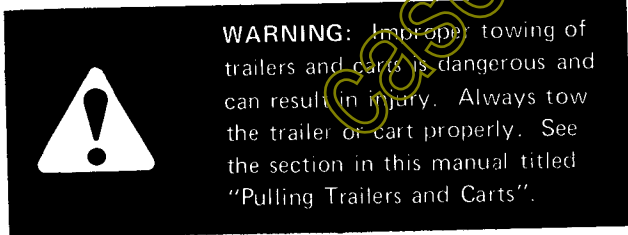

1. Maintain tire pressure between 16 and 22 p.s.i. (110 and 150 kPa).
2. Keep the wheel hubs well packed with automotive type chassis grease.

3. After using the cart for the first few hours, check and retighten the four axle support bolts and tongue bolts (if two-piece tongue).
4. A hole is provided in the trip latch for attaching a rope if desired. This will allow you to dump the cart from the tractor seat.
5. Before storing the cart, clean off dirt and touch up any scratched or bare metal surfaces to prevent rusting. Touch up paint is available from your dealer. Also be sure the wheel hubs are filled with grease to prevent moisture from entering.

NOTE: The Ingersoll Equipment Co., Inc. reserves the right to make improvements in design or changes in specifications at any time without incurring any obligation to install them on units previously sold.

casecoltingersoll.com