

Ingersoll

COMPACT TRACTORS

4018, 4021, 4023

4218, 4221, 4223

Operator's Manual 8-61220

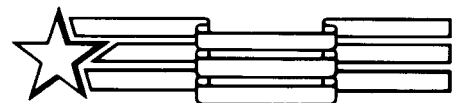

QUALITY IN THE AMERICAN TRADITION

Ingersoll Tractor Co. Portland, Maine 04103

casecoltingersoll.com



This Safety Alert Symbol Indicates Important Safety Messages In This Manual. When You See This Symbol, Carefully Read The Message That Follows And Be Alert To The Possibility Of Personal Injury Or Death.

IF THIS MACHINE IS USED BY AN EMPLOYEE OR IS LOANED OR RENTED, MAKE ABSOLUTELY CERTAIN THAT THE OPERATOR(S), PRIOR TO OPERATING:

- 1. IS INSTRUCTED IN SAFE AND PROPER USE.**
- 2. REVIEWS AND UNDERSTANDS THE MANUAL(S) PERTAINING TO THE MACHINE.**

751253



WARNING

BEFORE STARTING ENGINE

**STUDY OPERATOR'S MANUAL SAFETY MESSAGES
READ ALL SAFETY SIGNS ON MACHINE
CLEAR THE AREA OF OTHER PERSONS**

LEARN & PRACTICE SAFE USE OF CONTROLS BEFORE OPERATING

IT IS YOUR RESPONSIBILITY TO UNDERSTAND AND FOLLOW MANUFACTURER'S INSTRUCTIONS ON MACHINE OPERATION, SERVICE, AND TO OBSERVE PERTINENT LAWS AND REGULATIONS. OPERATOR AND SERVICE MANUALS MAY BE OBTAINED FROM YOUR EQUIPMENT DEALER.

⚠ WARNING:

The engine exhaust from this product contains chemicals known to the State of California to cause cancer, birth defects or other reproductive harm.

TABLE OF CONTENTS

SAFETY MESSAGES	4-9
TO THE OWNER.....	10
PRODUCT IDENTIFICATION (PIN) OR SERIAL NUMBERS (S/N).....	11
OPERATING INSTRUCTIONS	12-20
Operating Controls and Instruments	12-15
Prestarting Check List	16
Break-in Procedure.....	16
Starting Procedure.....	17
Stopping Procedure.....	18
Operating Procedure	19-20
TROUBLESHOOTING GUIDE	21
PREVENTIVE MAINTENANCE	22-36
Maintenance Chart	23
Capacities.....	23
Specifications	24
Over All Measurements.....	25
Wiring Diagram.....	26-27
Storage Battery.....	28
Jumper Cables and Booster Battery	28
Headlights.....	29
Fuse.....	29
Attachment Drive Clutch Break-in Procedure	29
Brake	30
Fuel.....	31
Hydraulic Oil	32
Hydraulic Oil Cooler.....	33
Hydraulic Oil Filter	33
Seat	34
Transaxle.....	34
Chassis Lubrication	35
Steering Adjustment	36
Toe-in Adjustment	36
MANUAL ORDERING PROCEDURE	37

SAFETY MESSAGES

The first twenty-five safety messages which follow are provided by the American National Standards Institute *(ANSI). Safety rules to supplement those provided by ANSI also appear on the following pages.

Study these rules carefully before starting and operating your tractor.



Separate Operator's Manuals are provided with the attachments purchased with your tractor. Refer to the appropriate attachment operator's manual for specific operating instructions and safety messages that apply to the attachment.



CAUTION: Know the controls and how to stop quickly. **READ THE OWNER'S MANUAL** and instructions furnished with attachments.



CAUTION: Do not allow children to operate the vehicle. Do not allow adults to operate it without proper instruction.



CAUTION: Do not carry passengers. Do not mow when children and others are around.



CAUTION: Clear the work area of objects (wires, rocks etc.), which might be picked up and thrown.



CAUTION: Disengage all attachment clutches and shift into neutral before attempting to start the engine (motor).



CAUTION: Disengage power to attachment(s) and stop the engine (motor) before leaving the operator's position.



CAUTION: Disengage power to attachment(s) and stop the engine (motor) before making any repairs or adjustments.



CAUTION: Disengage power to attachment(s) when transporting or not in use.



CAUTION: Take all possible precautions when leaving the vehicle unattended, such as disengaging the power take-off, lowering the attachment(s), shifting into neutral, setting the parking brake, stopping the engine, and removing the key.



CAUTION: Do not stop or start suddenly when going uphill or downhill. Mow down the face of steep slopes; never across or up the face. (This ANSI rule modified)



CAUTION: Reduce speed and exercise extreme caution on slopes and in sharp turns to prevent tipping or loss of control. Be especially cautious when changing direction on slopes.



CAUTION: Stay alert for holes rocks and roots in the terrain and other hidden hazards. Keep away from drop-offs.



CAUTION: Use care when pulling loads or using heavy equipment.

a. Use only approved drawbar hitch points.

b. Limit loads to those you can safely control.

c. Do not turn sharply. Use care when backing.

d. Use counterweights or wheel weights when suggested in the owner's manual.



CAUTION: Watch out for traffic when crossing or near roadways.



CAUTION: When using any attachments, never direct discharge of material toward bystanders nor allow anyone near the vehicle while in operation.



CAUTION: Handle gasoline with care—it is highly flammable.

- a. Use approved gasoline container.
- b. Never remove the cap of the fuel tank or add gasoline to a running or hot engine, or fill the fuel tank indoors. Wipe up spilled gasoline.
- c. Open doors if the engine is run in the garage—exhaust fumes are dangerous. Do not run the engine (motor) indoors.



CAUTION: Keep the vehicle and attachments in good operating condition, and keep safety devices in place and in working condition.



CAUTION: Keep all nuts, bolts and screws tight to be sure the equipment is in safe working condition.



CAUTION: Never store the equipment with gasoline in the tank inside a building where fumes may reach an open flame or spark. Allow the engine to cool before storing in any enclosure.



CAUTION: To reduce fire hazard, keep the engine free of grass, leaves, or excessive grease.



CAUTION: The vehicle and attachments should be stopped and inspected for damage after striking a foreign object, and the damage should be repaired before restarting and operating the equipment.



CAUTION: Do not change the engine governor settings or over speed the engine.



CAUTION: When using the vehicle with mower, proceed as follows:

- (1) Mow only in daylight or in good artificial light.
- (2) Never make a cutting height adjustment while the engine (motor) is running if the operator must dismount to do so.
- (3) Shut the engine (motor) off when removing the grass catcher or unclogged chute.
- (4) Check the blade mounting bolts for proper tightness at frequent intervals.



CAUTION: Under normal usage, the grass catcher bag material is subject to deterioration and wear. Check bag frequently for deterioration and wear and replace worn bags. Check that replacement bags comply with the original manufacturer's recommendations or specifications.



CAUTION: Set parking brake, shut off engine, remove key and wait until all engine and attachment motion has stopped before dismounting from the operator's seat.



CAUTION: Do not wear loose clothing, which may catch in moving parts.



CAUTION: Do not smoke when working near fuel.



CAUTION: Drive at a speed slow enough to insure safety and complete control at all times.



WARNING: Highway travel should be avoided. If necessary, use SMV safety emblem and lights for adequate warning to the operators of other vehicles. Check local government regulations.



CAUTION: Read operator's manual.

Know location and function of all controls.

Keep all shields and safety switches functional.

Before starting engine: disengage attachment drive and place travel control in neutral.

Remove objects from the terrain that could be thrown by the attachment.

Keep people and pets a safe distance away.

Never carry passengers.

Always look behind tractor before backing.

On any incline that the tractor can be safely operated use low range/gear.

Front end tip over can occur when operating on loading ramps or hills, back up ramps or hills.

Drive forward going down ramps or hills.

To park tractor: place travel control in neutral, set parking brake, disengage attachment drive, shut engine off and remove key.

Park tractor before servicing or making adjustments to tractor or attachments.

Failure to observe these precautions could result in serious injury or death.



CAUTION: Place the transmission in neutral, set the parking brake and stop the engine before standing between the tractor and attachment when hitching.



Become thoroughly familiar with all tractor and attachment controls before operating.



WARNING: Improper operation of your tractor on hillsides and slopes can be dangerous. Avoid improper operation! Read and follow the instructions given in the section titled "Hillside Operation" in this manual before operating your tractor.



CAUTION: If necessary to move tractor on a trailer, always back up onto the trailer and drive off the trailer



CAUTION: Hydraulic systems are highly pressurized. Escaping hydraulic oil, even an invisible pinhole leak, can penetrate body tissues causing serious injury. Use a piece of wood or cardboard when looking for leaks— never use the hands or other parts of the body.

Relieve hydraulic pressure before disconnecting circuits. When reassembling, make absolutely certain that all connections are tight

If injured by hydraulic oil escaping under pressure, see a doctor immediately. Serious complications may arise if medical attention is not given at once.



CAUTION: Too much air pressure in the tires can cause tire or rim failure. Never put more air pressure in a tire than specified in the operator's manual or on the sidewall of the tire. If the tire or rim explodes because of too much pressure, injury can result.



CAUTION: When removing a battery, always disconnect the (-) negative ground cable first. When installing the battery, always connect the (-) negative ground cable last.



CAUTION: Storage areas for batteries must be well ventilated to prevent accumulation of hydrogen gas from newly recharged batteries.



DANGER: Batteries produce explosive charges. Keep sparks, flame and cigarettes away. Ventilate when charging or using in enclosed space. Always shield eyes when working near batteries.



CAUTION: When working around storage batteries, remember that all of the exposed metal parts are “live”. Never lay a metal object across the terminals as a spark or short circuit may result. Sparks, lighted matches and exposed flames must be kept away from the battery due to the presence of explosive gas in the battery. The liquid in the batteries is acid. Use care not to spill it on hands or clothing.



POISON: Batteries contain sulfuric acid, which can cause severe burns. Avoid contact with skin, eyes or clothing. Antidote: **EXTERNAL**, flush with water; **INTERNAL**, drink large quantities of water or milk. Follow with milk of magnesia, beaten egg or vegetable oil. Call physician immediately; **EYES**, flush with water for 15 minutes and get prompt medical attention. Keep out of reach of children.



WARNING: To jumpstart this machine, connect positive jumper cable to battery terminal on starter solenoid and connect negative jumper cable to good engine ground. Start engine only when seated in operator’s seat. Stop engine before leaving machine. Disconnect jumper cables. Any other method would result in uncontrolled machine movement.



CAUTION: Never wear rings or metal watchbands when working with the tractor electrical system or battery as you may ground a live circuit.



CAUTION: Operate tractor from proper seat position only. Any other method could result in a serious injury.



CAUTION: Before attempting to service the attachment drive clutch, be sure to remove tractor key and spark plug wire(s).



Remember, a careful operator is always the best insurance against an accident. Give complete and undivided attention to the job at hand.



Never operate machine while under the influence of drugs or alcohol.



CAUTION: Disengage power to mower before backing up. Do not mow in reverse unless absolutely necessary and then only after observation of the entire area behind the mower.



CAUTION: Do not drive in reverse unless completely necessary while your attachment is operating.



CAUTION: When adjusting steering wheel free play, make certain that some free play remains between the sector gear and pinion gear. A tight fit, with no clearance between the two gears, may cause binding and tooth failure.

IMPORTANT: Always install new decals whenever the old decals are destroyed, lost, painted over or illegible. When individual parts are replaced that have decals attached, be sure to install a new decal with the new part. Replacement decals are available from your dealer.

HILLSIDE (SLOPE) OPERATION



WARNING: Improper operation of your tractor on hillsides and slopes can be dangerous. Avoid improper operation! Read and follow the instructions given in the section titled “Hillside Operation” in this manual before operating your tractor.

Avoid operating tractor on hillsides and slopes. To minimize the possibility of accidents while operating on hills and/rough terrain, obey a combination of rules, practices and good common sense.

These include:

1. Reading, understanding, and obeying all written safety messages appearing on decals on the machine and in operator’s manuals.
2. Learning from your operator’s manual and carefully from EXPERIENCE how to operate your tractor correctly. Know your tractor’s limitations.
3. Knowing the terrain on which you are operating your tractor. There are terrain conditions on which your tractor cannot be operated!
4. Learning to expect changes in operating conditions. Adding or removing attachments or weight to your tractor will make your tractor perform differently. Rain, snow, loose gravel, wet grass, etc., change the tractive conditions of the terrain requiring changes in your operating technique or not to operate on that terrain.

The following paragraphs will cover these practices one at a time. Read and study them. The examples provided are not all inclusive but will give you a firm understanding of the requirements for avoiding accidents while operating your tractor.

THE OPERATOR IS THE SOLE JUDGE AS TO THE DEGREE OF SLOPE ON WHICH THIS TRACTOR CAN BE SAFELY OPERATED. IF IN DOUBT THAT THIS TRACTOR CAN BE SAFELY OPERATED ON A PARTICULAR SLOPE, DO NOT OPERATE ON THAT SLOPE! COMMON SENSE MUST PREVAIL.

Read, Understand, Obey:

Safety messages are found on the tractor and in the operator’s manuals. These must be understood by the tractor operator to be of value. Be sure that these messages are studied before starting and/or operating the tractor by an operator not familiar with this particular tractor.

Learn to Operate:

Learn your tractor’s controls from decals on the tractor and from instructions in the operator’s manual. Practice how to properly manipulate these controls. Practice must be done in a flat area, clear of obstacles and bystanders. Learn your tractor’s operating characteristics and limitations. These include:

- a. amount of engine power available
- b. engine governor response
- c. tractive ability
- d. steering characteristics
- e. braking characteristics
- f. movement of travel lever
- g. forward and reverse ground speeds
- h. speed of attachment lift
- i. and others

Attempting any operation, which approaches or exceeds the tractor’s limitation is risking an accident.

Know the Terrain:

Know the terrain on which you are working. Find hidden obstacles by walking through and inspecting the area prior to operating your tractor on it. Mark obstacles, such as, rocks, ruts or holes with a 6 ft. long pole and red flag and stay well clear of these obstacles when operating.

Operate your tractor at a ground speed slow enough to insure complete control at all times.

Place the transmission in low gear and regulate the throttle control lever slowly and smoothly to maintain this safe speed. Do not stop on a hill or slope to change gears.

Always drive in a forward direction when proceeding downhill. Never drive up a hill. If necessary, back up a hill to the desired position. Always back up loading ramps and tilt bed trailers. If necessary to turn while on a hill, always turn downward.

Your judgment, based on operating experience is the final word in deciding if you should negotiate any given hill or slope. If you are in doubt about safety, **STAY OFF THE SLOPE.**

Under no circumstances should an inexperienced operator attempt to use your tractor on slopes or hillsides.

You may encounter some terrain on which your tractor cannot be operated even if a different piece of equipment has operated there in the past.

Learn to Compensate for Changes in Operating Conditions:

Adding or removing attachments or ballast (such as wheel weights or fluid) change the weight and weight distribution of your tractor and, therefore, changes your tractor's operating characteristics.

Be alert to these changes. Practice operating the tractor after each change has been made.

Adding an attachment (weight) to the rear of the tractor reduces the weight on the front axle. Adding an attachment (weight) to the front of the tractor reduces weight on the rear of the tractor. You must add counterweight to the front if rear mounted attachment is installed. You must add counterweight to the rear if a front mounted attachment is installed.

Tractive conditions will vary with weather and terrain and equipment.

Areas wet with dew or rain will be more slippery than when dry. Areas covered with loose gravel are more slippery than firm dry ground. Greater stopping distances are required in these slippery areas.

Spinning rear wheels tend to move the tractor sideways. The addition of tire chains will provide more traction to the rear wheels in the forward-reverse direction but less stability in the sideways direction. Chains will cause more abrupt starting and stopping.

The final word in safe tractor operation rests on your judgment.

If in doubt of your safety, STAY OFF THE SLOPE.

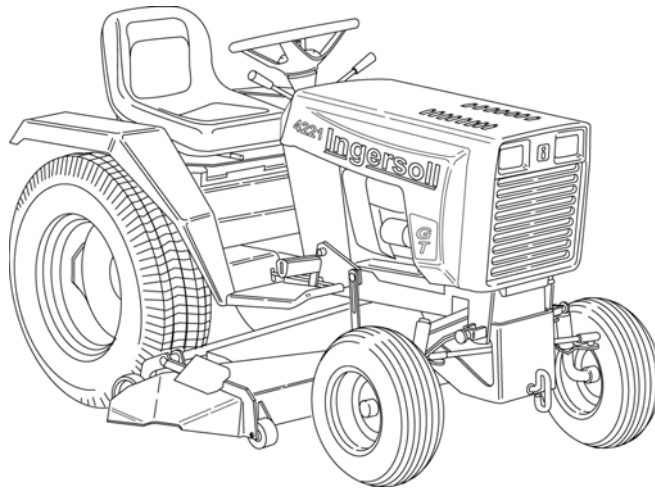

FIGURE 1

TO THE OWNER

The Maintenance you give your new tractor is important. Use this manual as your guide. Follow these instructions and tips to make sure your tractor operates efficiently for many years.

We are a factory authorized dealer. We have replacement parts which are the same as the original equipment.

If you need additional aid or information, contact us.

Your Authorized Dealer

NOTE: Ingersoll Tractor Co., reserves the right to make improvements in design or changes in specifications at any time without incurring any obligation to install them on units previously sold.

IMPORTANT: This manual covers many different model tractors. The illustrations used in this manual may not be of your tractor.

NOTICE

A spark arrester or spark arrester muffler must be used on some machines. Check the laws in your area.

Some states have regulations for the use of this machine in agriculture, forestry and construction. These laws control the maintenance of spark arrester equipment. These laws also control the installation of spark arrester equipment on the exhaust system of naturally aspirated engines (engines without a turbocharger).

RADIO INTERFERENCE REGULATIONS OF CANADA

Tractors taken into Canada after September 1, 1976 must have resistor spark plugs.

Resistor spark plugs and resistor wires for the spark plug must be used for replacement.

RIGHT HAND AND LEFT HAND IDENTIFICATION

The words "Right, Left, Front and Rear" as used in this manual indicate directions when you are in the operator's seat in the normal operating position.

PRODUCT IDENTIFICATION NUMBER (P.I.N.) OR SERIAL NUMBER

When you need parts or information, or when you write to your authorized dealer, always give the:

1. Tractor Model Number
2. Tractor Product Identification Number (P.I.N.)
3. Engine Model Number
4. Engine Serial Number
5. Engine Specification Number

For reference, write the numbers below

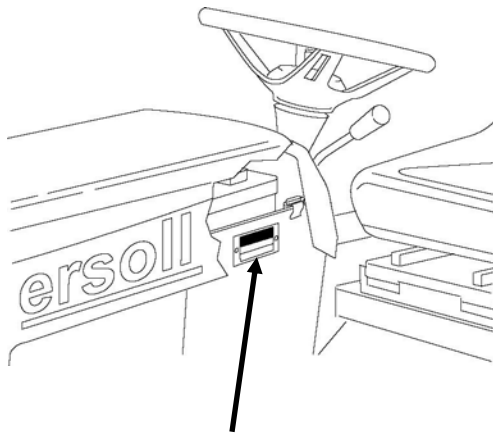

**TRACTOR MODEL AND
PRODUCT IDENTIFICATION
NUMBER**

FIGURE 2

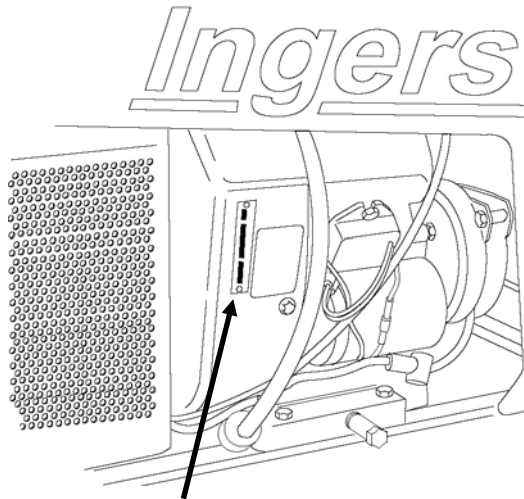

**ENGINE MODEL, SERIAL AND
SPECIFICATION NUMBERS**

BRIGGS & STRATTON ENGINE
FIGURE 3

OPERATING INSTRUCTIONS

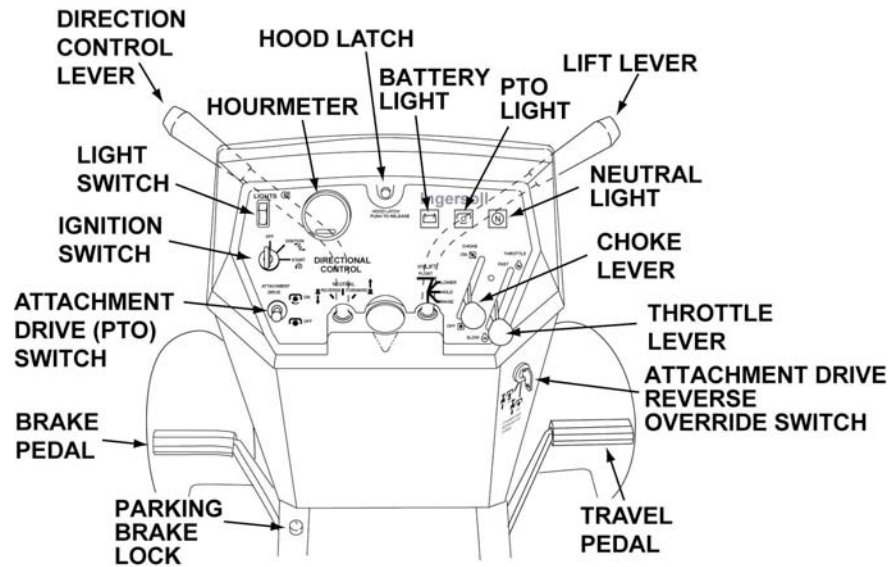

FIGURE 4

OPERATING CONTROLS AND INSTRUMENTS



CAUTION: Operate tractor from proper seat position only. Any other method could result in a serious injury.



Become thoroughly familiar with all tractor and attachment controls before operating.



CAUTION: Know the controls and how to stop quickly. **READ THE OWNER'S MANUAL** and instructions furnished with attachments.



Never operate machine while under the influence of drugs or alcohol.

1. IGNITION KEY AND STARTER SWITCH

TO START: Turn the key to the right and hold in the "START" position.

TO RUN: Release the key to the "RUN" position when the engine starts.

TO STOP: Turn the key to the left to the "OFF" position.

2. CHOKE

TO CLOSE THE CHOKE: Push the choke lever forward. Close the choke to start a cold engine.

TO OPEN THE CHOKE: Pull the choke lever rearward. Open the choke slowly after the engine starts.

The choke must be open during normal operation or when you start a warm engine.

3. THROTTLE

ENGINE LOW IDLE: Pull the throttle lever rearward. Put the throttle in the "SLOW" position when starting and when stopping the engine. This permits a warming and cooling period.

TO INCREASE ENGINE SPEED: Push the throttle lever forward until the needed engine speed is reached.

Decrease the engine speed during operation for maximum fuel efficiency. Do not cause engine lugging. Lugging will cause too much heat and damage to the engine.



CAUTION: Do not change the engine governor settings or over speed the engine.

4. HEADLIGHTS

TO ILLUMINATE: Press the switch to illuminate the headlights.

TO TURN OFF: Press the switch to turn off the headlights

5. BATTERY VOLTAGE INDICATOR LIGHT

The battery voltage indicator light will illuminate when the battery voltage is low and will go out when the battery voltage is acceptable.

It is normal for the light to illuminate when the tractor is first started after a period of non-use and to glow when the tractor engine is operated at low idle speed.

Stop the engine and have the problem corrected if the indicator light does not go out after running the engine at normal operating speed after a few minutes of operation.

It is normal for the Battery Voltage Indicator Light to remain out if the engine is stopped when the battery is fully charged and the ignition key is turned to the "run" position.

6. HOUR METER

The electric hourmeter records hours of operation whenever the key is in the "RUN" position.

Utilize the hourmeter to meet the required maintenance schedule.

7. BRAKE PEDAL

TO ACTUATE THE BRAKE: Push the brake pedal fully down.

This action will return the travel control lever to the "NEUTRAL" position on 4000 series tractors. The tractor will come to a quick stop.

NOTE: Do not use the above method if possible.

The tractor can be stopped smoothly by slowly returning the travel control lever to the "NEUTRAL" position on 4000 series tractors or slowly raising the TRAVEL PEDAL on 4200 series tractors.

Actuate the brake fully if you can not stop the tractor with the travel control lever (4000 series) or travel pedal (4200 series).

See the Operating Procedure Section of this manual for a more complete description of stopping travel.

8. PARKING BRAKE LOCK

TO ENGAGE: Push the brake pedal fully down. Push down on the parking brake lock.

TO DISENGAGE: Push the brake pedal a small amount and release.

A spring will disengage the parking brake lock.

9. HYDRAULIC ATTACHMENT LIFT LEVER

TO LIFT: Run the engine

Pull the lever rearward.

Release the lever when the needed height is reached.

TO LOWER: Run the engine.

Push the lever forward a small amount.

Release the lever when the needed height is reached.

When you release this lever, a spring will automatically return the lever to the "NEUTRAL" position.

THE "FLOAT" POSITION: Push the lever fully forward.

A detent holds the lever in the "FLOAT" position. The lever must be manually returned to the "NEUTRAL" position from the "FLOAT" position.

The "FLOAT" position allows the attachment lift arms to move with the attachment. This position is not recommended for mowing operations as a poor cut can result.

See the instructions included with each attachment for correct attachment lift lever use.

10. ATTACHMENT DRIVE (PTO) SWITCH

TO ENGAGE: Pull switch toggle out and push upward. See Attachment Drive Clutch Break-in procedure in maintenance section in this manual before operating your attachment.

The center dash panel indicator light will illuminate when the attachment drive switch is on.

TO DISENGAGE: Push switch down.

The center dash panel indicator light will go out when the attachment drive switch is off.

NOTE: The attachment drive switch must be off before you can start the engine.

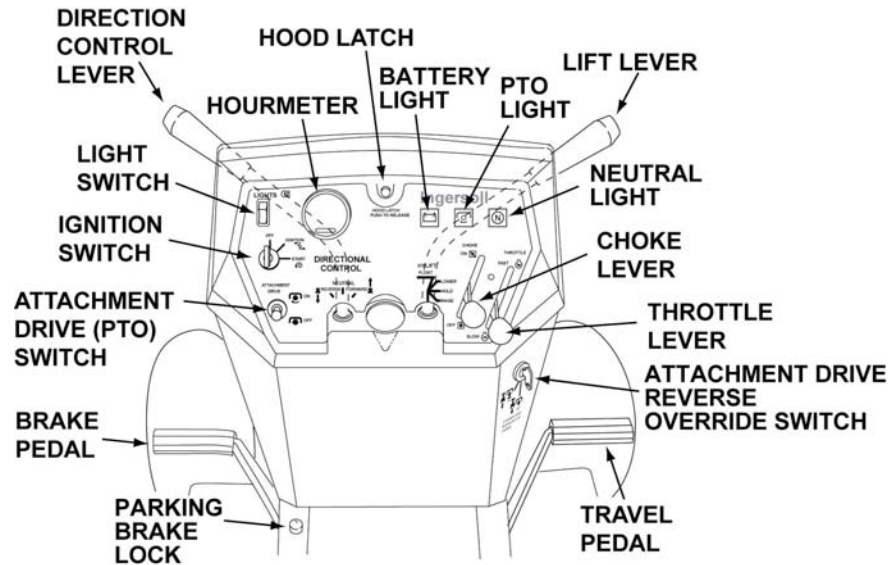

FIGURE 5

11. ATTACHMENT DRIVE REVERSE OVERRIDE SWITCH



CAUTION: Do not drive in reverse unless completely necessary while your attachment is operating.

Your tractor is equipped with a safety device that shuts off clutch operated attachments, such as the mower and snowblower, when the tractor is driven in reverse.

TO OVERRIDE THIS DEVICE: Turn the key to the left "ON" position.

TO ACTIVATE THIS DEVICE: Turn the key to the right "OFF" position.

12. DUAL RANGE TRANSAXLE

TO SELECT LOW RANGE: Put travel control lever in the "NEUTRAL" position.

Stop tractor.

Push range shift lever down and to the left. Release lever up into "LOW RANGE" notch.

TO SELECT NEUTRAL: Put travel control lever in "NEUTRAL" POSITION.

Stop tractor.

Push range shift lever down and move lever to align with the "NEUTRAL" notch and release.

TO SELECT HIGH RANGE: Put travel control lever in the "NEUTRAL" position.

Stop tractor.

Push range shift lever down and to the right. Release lever up into the "HIGH RANGE" notch.

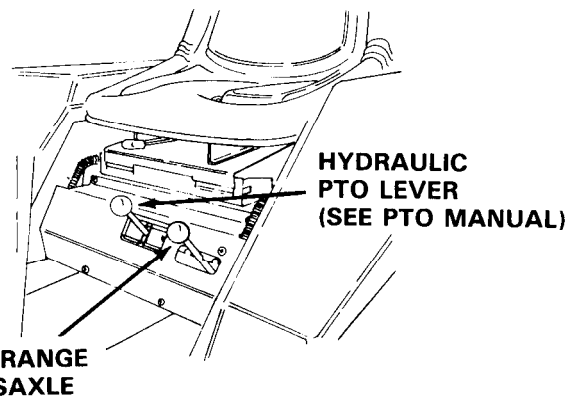

FIGURE 6

13. DIRECTION CONTROL LEVER

TRAVEL CONTROL LEVER (4000 SERIES)

TO STOP TRAVEL: Put the travel control lever in the "NEUTRAL" position.

TO START FORWARD TRAVEL: Depress the travel control lever slightly. Slowly and in small amounts move the travel control lever forward.

Speed and power will increase as the lever is moved toward the full forward position.

TO START REVERSE TRAVEL: Depress the travel control lever slightly. Slowly and in small amounts move the travel control lever rearward.

Speed and power will increase as the lever is moved toward the full reverse position.

DO NOT USE FULL SPEED IN REVERSE.

Depress the travel control lever whenever you change the lever position to have smoother operation and control.

The travel control lever automatically returns to the "NEUTRAL" position when the brake is actuated. You must hold the travel lever in the needed position to maintain travel while the brake is actuated.

A neutral start switch is actuated by the travel control lever. The lever must be in the "NEUTRAL" position before you can start the engine.

The right hand dash panel indicator light will illuminate when the travel control lever is in the "Neutral" position. The indicator light will go out if the travel control lever is moved from the "Neutral" position into either forward or reverse.

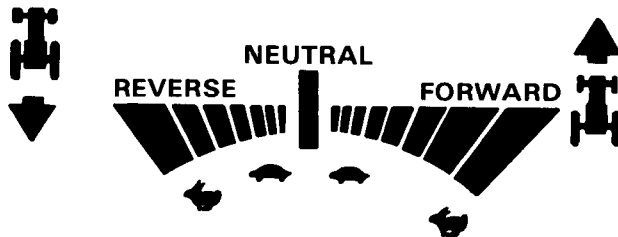

FIGURE 7 TRAVEL CONTROL LEVER

DIRECTION CONTROL LEVER (4200 SERIES)

TO STOP TRAVEL: Slowly release the travel pedal to the fully raised position. Put the direction control lever in the "NEUTRAL" position.

TO START FORWARD TRAVEL: Put the direction control lever into the "FORWARD" position. Slowly press the travel pedal down with your right foot.

Speed and power will increase as the travel pedal is pressed down.

IMPORTANT: The travel pedal must be fully raised and the tractor must come to a complete stop before you move the direction control lever between "FORWARD" and "REVERSE"

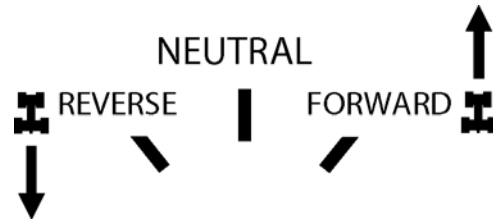

FIGURE 8 DIRECTION CONTROL LEVER

TO START REVERSE TRAVEL: Put the direction control into the "REVERSE" position. Slowly press the travel pedal down with your right foot.

Speed and power will increase as the travel pedal is pressed down.

DO NOT USE FULL SPEED IN REVERSE.

A neutral start switch is actuated by the direction control lever. The lever must be in the "NEUTRAL" position before you can start the engine.

The right hand dash panel indicator light will illuminate when the travel control lever is in the "NEUTRAL" position. The indicator light will go out if the travel control lever is moved from the "NEUTRAL" position into either forward or reverse.

PRESTARTING CHECK LIST

CAUTION: Read operator's manual.

Know location and function of all controls.

Keep all shields and safety switches functional.



Before starting engine: disengage attachment drive and place travel control in neutral.

Remove objects from the terrain that could be thrown by the attachment.

Keep people and pets a safe distance away.

Never carry passengers.

Always look behind tractor before backing.

On any incline that the tractor can be safely operated use low range/gear.

Front end tip over can occur when operating on loading ramps or hills, back up ramps or hills.

Drive forward going down ramps or hills.

To park tractor: place travel control in neutral, set parking brake, disengage attachment drive, shut engine off and remove key.

Park tractor before servicing or making adjustments to tractor or attachments.

Failure to observe these precautions could result in serious injury or death.



CAUTION: Do not wear loose clothing, which may catch in moving parts.



CAUTION: Disengage power to attachment(s) and stop the engine (motor) before making any repairs or adjustments.

CAUTION: Handle gasoline with care—it is highly flammable.



- a. Use approved gasoline container.
- b. Never remove the cap of the fuel tank or add gasoline to a running or hot engine, or fill the fuel tank indoors. Wipe up spilled gasoline.
- c. Open doors if the engine is run in the garage—exhaust fumes are dangerous. Do not run the engine (motor) indoors.



CAUTION: Do not smoke when working near fuel.

1. Use only clean fuel, oil, container and funnel.
2. Apply oil or grease to all the specified points shown in the Lubrication Chart.
3. Check the oil level in the engine and add oil as required.
4. Check the engine air cleaner and air intake screen for dirt or obstructions. Clean as required.
5. Fill the fuel tank with clean fuel. Clean the area around the fuel cap before you remove the cap. The requirements are listed in the Fuel Specifications Section of this manual.
6. Check the ventilation hole in fuel tank cap and clean as required.
7. Check all operating controls and instruments for correct function before using the tractor

BREAK-IN PROCEDURE

Controlled break-in is the ideal fitting of all internal moving metal parts. Using the proper oil and applying a conscientious maintenance program during this period helps assure satisfactory service from your engine.

Maintain the proper cooling and lubrication during break-in. Run the engine at half load for the first

three hours with intermittent periods of full load to control engine break-in.

Check the oil level at least every five operating hours. Add oil to keep it at the proper level, but never overfill as overfilling may cause the oil to foam and enter the breather system, resulting in high oil consumption and oil accumulation in air cleaner housing.

STARTING PROCEDURE (Operating the Tractor)



CAUTION: Operate tractor from proper seat position only. Any other method could result in a serious injury.



CAUTION: Do not wear loose clothing, which may catch in moving parts.

NOTE: Your tractor is equipped with an ignition interlock switch under the seat.

The tractor engine will stop if you get off the seat when the attachment drive clutch is in the "ON" position, or the travel control lever is in "FORWARD" or "REVERSE" position.

DO NOT operate your tractor and have this interlock repaired if it does not function correctly.

1. Put the travel control lever in the "NEUTRAL" position.



CAUTION: Disengage all attachment clutches and shift into neutral before attempting to start the engine (motor).

2. Put the attachment drive switch in the "Off" position.
3. Push the choke lever forward to close the choke.

The choke setting will change according to the air temperature, engine temperature, and grade of fuel.



CAUTION: Do not allow children to operate the vehicle. Do not allow adults to operate it without proper instruction.



CAUTION: Do not carry passengers. Do not mow when children and others are around.

4. Push the throttle lever forward approximately 1/3 of the way between the "SLOW" and "FAST" positions.
5. Turn the ignition key to the right and hold in the "START" position. Release the key to the "RUN" position when the engine starts running.

NOTE: Release the key immediately when the engine starts. If you hold the key in the "START" position after the engine is running damage can occur. Release the key after 30 seconds if the engine does not start running. Wait 3 minutes before you try again.

6. Pull the choke lever rearward slowly after the engine starts running.

7. Permit the engine to warm before applying a load.

NOTE: The hydraulic system must be warm before you use the tractor when air temperatures are less than 32°F (0°C). Use the following procedure:

- a. Set the throttle 1/3 of the way between the "SLOW" and "FAST" position.
- b. Select the "NEUTRAL" position of the dual range transaxle.
- c. Move the (travel) direction control lever to the full "FORWARD" position. Press the foot travel pedal fully down on 4200 series tractors.
- d. Run for several minutes before operating the tractor. A noise can occur when the hydraulic system is cold.



Separate Operator's Manuals are provided with the attachments purchased with your tractor. Refer to the appropriate attachment operator's manual for specific operating instructions and safety messages that apply to the attachment.



Remember, a careful operator is always the best insurance against an accident. Give complete and undivided attention to the job at hand.

IMPORTANT: DO NOT TRY TO START THE TRACTOR BY PUSHING OR TOWING. SERIOUS DAMAGE WILL RESULT TO THE DRIVE SYSTEM.

STOPPING PROCEDURE (Operating the Tractor)

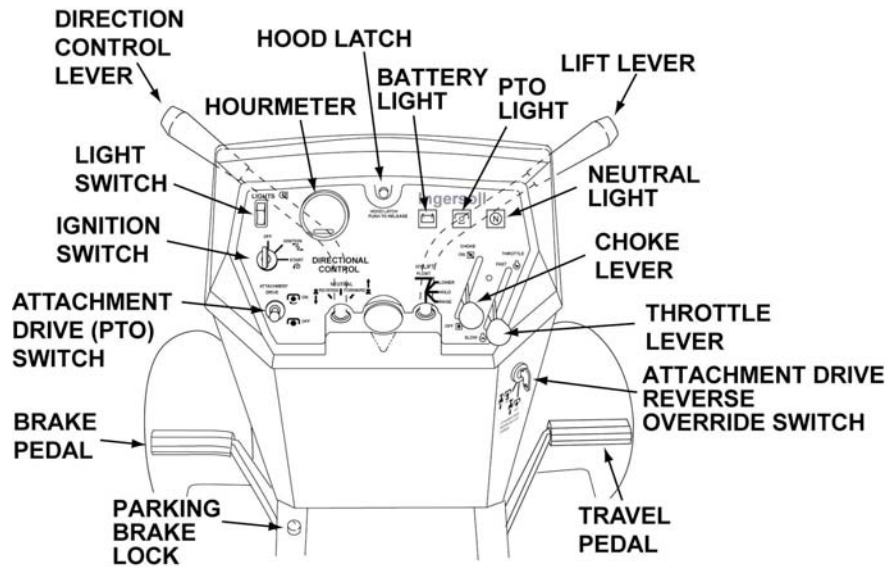

FIGURE 9



CAUTION: Know the controls and how to stop quickly. READ THE OWNER'S MANUAL and instructions furnished with attachments.

1. (4000 series) Slowly move the travel control lever to the "NEUTRAL" position.

(4200 series) Slowly release the travel pedal to the fully raised position. Put the direction control lever in the "NEUTRAL" position.

2. Completely stop the tractor. Actuate the brake pedal if necessary.
3. Engage the parking brake lock.
4. Pull the throttle lever rearward to the "SLOW" position.



CAUTION: Set parking brake, shut off engine, remove key and wait until all engine and attachment motion has stopped before dismounting from the operator's seat.

5. Permit the engine to cool. Run the engine at idle for several minutes if the work load was severe.

6. Turn the key to the left to the "OFF" position.

NOTE: Muffler after bang can be prevented by closing the choke at the same time the key switch is turned to the "OFF" position. This action prevents the entry of air into the muffler as the engine comes to a stop and therefore prevents combustion within the muffler.

7. Remove the ignition key.



CAUTION: Take all possible precautions when leaving the vehicle unattended, such as disengaging the power take-off, lowering the attachment(s), shifting into neutral, setting the parking brake, stopping the engine, and removing the key.



CAUTION: Disengage power to attachment(s) when transporting or not in use.

OPERATING PROCEDURE (Operating the Tractor)

Operate the tractor for the first time on a flat area clear of obstructions and persons. Learn the operating characteristics of your tractor before trying the first job.

1. Select the correct gear range for the job.
2. "LOW" range is for all working operations and hillside use. Always use "LOW" range on hillsides or inclines.

CAUTION: Use care when pulling loads or using heavy equipment.



- a. Use only approved drawbar hitch points.
- b. Limit loads to those you can safely control.
- c. Do not turn sharply. Use care when backing.
- d. Use counterweights or wheel weights when suggested in the owner's manual.

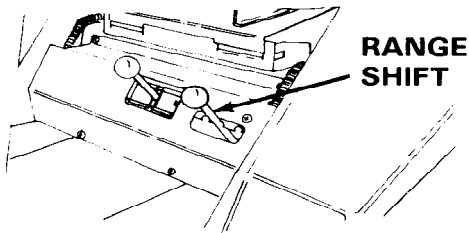

FIGURE 10

3. "HIGH" range is for transport only, "HIGH" range must not be used for hillside operation.
4. If the range shift does not move easily, rotate the gears.

To rotate the gears:

- a. Move the (travel) direction control lever a small amount into the "FORWARD" position. Press the foot travel pedal slightly (4200 series).
- b. Return the travel control lever to the "NEUTRAL" position.

IMPORTANT: Completely stop the tractor motion before changing the range. The range shift lever must be completely seated in the "LOW" or "HIGH" range notch. Gear damage can occur if the lever is not in the correct position.

5. Push the throttle lever forward until you get the needed engine speed.

Decrease engine speed during operation for maximum fuel efficiency. Do not cause engine lugging. Lugging will cause more than normal heat and damage to the engine.

6. TO USE FORWARD TRAVEL:

- a. Depress the (travel) direction control lever slightly and move it from the "NEUTRAL" position toward the "FORWARD" position. Press the foot travel pedal down for desired speed (4200 series).
- b. When you reach the correct speed, release the travel lever (4000 series).
- c. Release the foot travel pedal to stop (4200 series). Return the travel control lever to the "NEUTRAL" position to stop (4000 series).
- d. Actuate the brake pedal if the tractor does not stop.

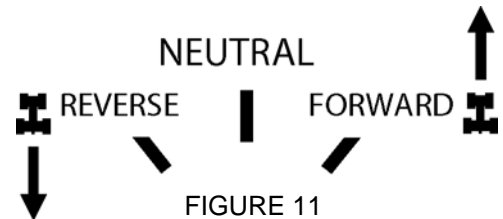

FIGURE 11

7. TO USE REVERSE TRAVEL:

- a. Depress the (travel) direction control lever slightly and move it from the "NEUTRAL" position toward the "REVERSE" position. Press the foot travel pedal for desired speed (4200 series). Do not travel at full speed in reverse.
- b. Release the travel foot pedal to stop (4200 series). Return the travel control lever to the "NEUTRAL" position to stop (4000 series).
- c. Actuate the brake pedal if the tractor does not stop.

Always be careful and look behind when you drive in reverse.

Do not travel in reverse down a hill or ramp. Use reverse travel to move up a hill or ramp. Always use forward travel when you come down a hill or ramp.



CAUTION: Do not stop or start suddenly when going uphill or downhill. Mow down the face of steep slopes; never across or up the face. (This ANSI rule modified)



WARNING: Improper operation of your tractor on hillsides and slopes can be dangerous. Avoid improper operation! Read and follow the instructions given in the section titled “Hillside Operation” in this manual before operating your tractor.

8. TO ACTUATE BRAKES .Hillside Operation (4000 series only)

Hold the travel control lever in the needed position, then push on the brake pedal.

When you actuate the brake, the travel control lever will return to the “NEUTRAL” position unless you hold the lever in the needed position.

The travel control lever can be moved (but the lever must be held) while the brake is actuated.

IMPORTANT: Keep the brakes in good repair and correctly adjusted at all times. See the preventive maintenance section of this manual or see your dealer for brake repair.

9. (4000 series) Do not move the travel control lever from “REVERSE” to “FORWARD” while the tractor is moving. This can cause the front of the tractor to raise off the ground. Stop reverse travel completely before you start forward travel. This is especially important while on a hill or slope. (4200 series: You cannot move the direction control lever unless the foot travel control pedal is fully released)

10. The rear wheels can slip or spin and an engine overload can occur while you go up a small slope. Turn the front wheels toward the bottom of the hill before the loss of all traction or power.

Do not permit the tractor to move rearward down any slope or hillside.

a. A return to forward travel will cause too much torque at the rear wheels. The front wheels can rise off the ground and cause severe injury to the operator.

b. Turning the front wheels can cause too much thrust to the side. The tractor can roll over and cause severe injury to the operator.

Always use reverse travel to move up a hill or slope. Always use forward travel to move down a hill or slope.

11. Decrease the travel speed before you turn the tractor.



CAUTION: Reduce speed and exercise extreme caution on slopes and in sharp turns to prevent tipping or loss of control. Be especially cautious when changing direction on slopes.

12. Engage the attachment drive before you put a load on the attachment.

IMPORTANT: To prevent clutch damage, do not engage the attachment drive clutch with engine throttle in “FAST” position.

Actuate the lawnmower over an area of thin grass or an area that has been cut.



CAUTION: Disengage power to mower before backing up. Do not mow in reverse unless absolutely necessary and then only after observation of the entire area behind the mower.

Actuate the tiller while in the transport position. Then lower the tiller into the soil to the needed depth.

Actuate the snowcaster before you make contact with the snow.

13. Read your attachment manual for complete attachment operation information.



CAUTION: Do not drive in reverse unless completely necessary while your attachment is operating.



CAUTION:When using any attachments, never direct discharge of material toward bystanders nor allow anyone near the vehicle while in operation.

TROUBLESHOOTING GUIDE

CAUSES

SOLUTIONS

ENGINE WILL NOT START

1. Attachment Drive PTO in "ON" position.
2. Travel lever in "FORWARD" or "REVERSE" position.
3. No fuel in tank.
4. Vent in fuel tank cap restricted or wrong cap on tank.
5. Faulty spark plug(s)
6. Other causes.

1. Put electric clutch in "OFF" and hydraulic PTO (if equipped) in "NEUTRAL" position.
2. Put travel lever in "NEUTRAL" position.
3. Fill tank with fresh, clean fuel.
4. Clean vent, use properly vented cap.
5. Replace spark plug(s).
6. See your dealer.

ENGINE LACKS POWER

1. Choke partially closed.
2. Dirty Air Cleaner
3. Use of old, stale fuel.
4. Faulty spark plug(s).
5. Engine overheating.
6. Vent in fuel tank cap restricted or wrong cap on tank.
7. Other causes.

1. Open choke.
2. Clean or replace air cleaner.
3. Use clean, fresh fuel, replace fuel filter.
4. Replace spark plug(s).
5. Clean air baffles and cooling fins.
6. Clean vent, use properly vented cap.
7. See your dealer.

ENGINE WILL NOT RUN

1. Engine stops when you get off seat.
2. Engine stops when you put travel lever in "FORWARD" or "REVERSE" or you engage electric clutch or hydraulic PTO (if equipped).
3. Also see "ENGINE LACKS POWER" in this guide.
4. Other causes.

1. a. Sit in seat during normal operation.
b. Put electric clutch in "OFF" and hydraulic PTO (if equipped) in "NEUTRAL" position.
c. Put travel lever in "NEUTRAL" position.
2. a. Sit in seat during normal operation.
b. Faulty seat switch.
c. Faulty seat switch connector or connector is loose.
3. Check causes.
4. See your dealer.

PREVENTIVE MAINTENANCE

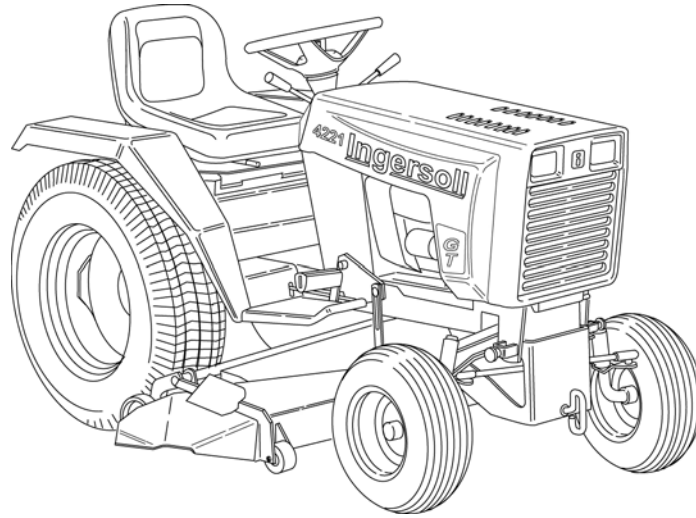

FIGURE 12

As the owner of an Ingersoll tractor, you have a machine that is made to high quality standards.

Preventive maintenance is important to you.

Preventive maintenance is the most efficient way to keep your tractor in top operating condition.

The first part of this manual covers instructions needed for daily operation. The following instructions will help you in maintenance and adjustment of your tractor.

Also see your engine manual for maintenance and adjustment of your engine.

TRACTOR MAINTENANCE CHART
(ALSO SEE ENGINE MANUAL FOR ENGINE MAINTENANCE)

MAINTENANCE PROCEDURE	PAGE	FREQUENCY
Check hydraulic oil level	32	Daily
Check and clean obstructions from oil cooler	33	Daily
Grease front spindles, axle pivot pin, front wheel bearings, steering gear	35	25 Hours
Oil travel lever, implement lift lever	N/A	50 Hours
Oil brake linkage	30	50 Hours
Check two speed transaxle oil	34	100 Hours
Change two speed transaxle oil	34	500 Hours
Change hydraulic system oil	32	500 Hours
Change hydraulic oil filter	33	500 Hours

CAPACITIES

HYDRAULIC SYSTEM

REFILL 6 qts. (5.6 l)

TOTAL SYSTEM 6.5 qts. (6 l)

TRANSAXLE..... 1 pint (.5 l)

FUEL TANK 3 gallons (11.4 l)

ENGINE CRANKCASE

BRIGGS & STRATTON

WITHOUT FILTER 1.5 qts. (1.4 l)

WITH FILTER 1.75 qts. (1.65 l)

OVERALL MEASUREMENTS

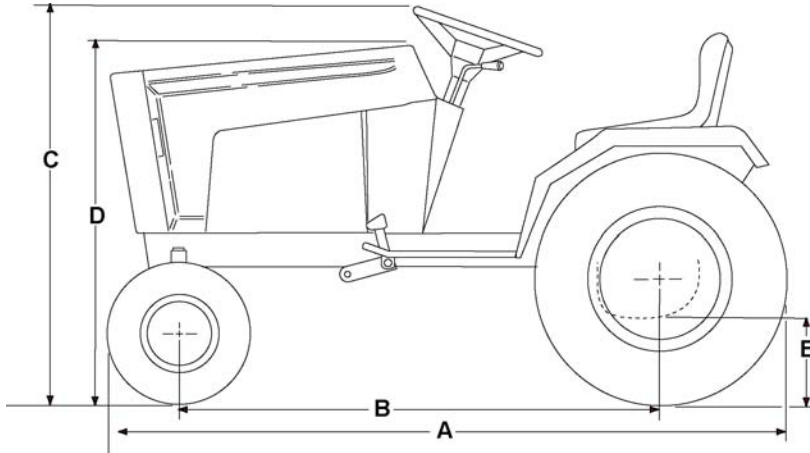

FIGURE 13

**4018, 4021, 4023
4218, 4221, 4223**

A	Overall Length	72" (1830 mm)
B	Wheel Base	48" (1220 mm)
C	Overall Height	43.5" (1110 mm)
D	Hood Height - Rear	39" (990 mm)
E	Minimum Ground Clearance at Gear Case	11" (280 mm)
	Rear Wheel Tread	31.5" (800 mm)
	Front Wheel Tread	33.5" (850 mm)
	Overall Width	41" (1050 mm)
	Tractor Weight	765 lbs (347 kg)
	*Turning Radius	37" (940 mm)

* Measure to outside edge of rear wheel

4200 SERIES WIRING DIAGRAM With Rear Chassis PTO Wire Harness

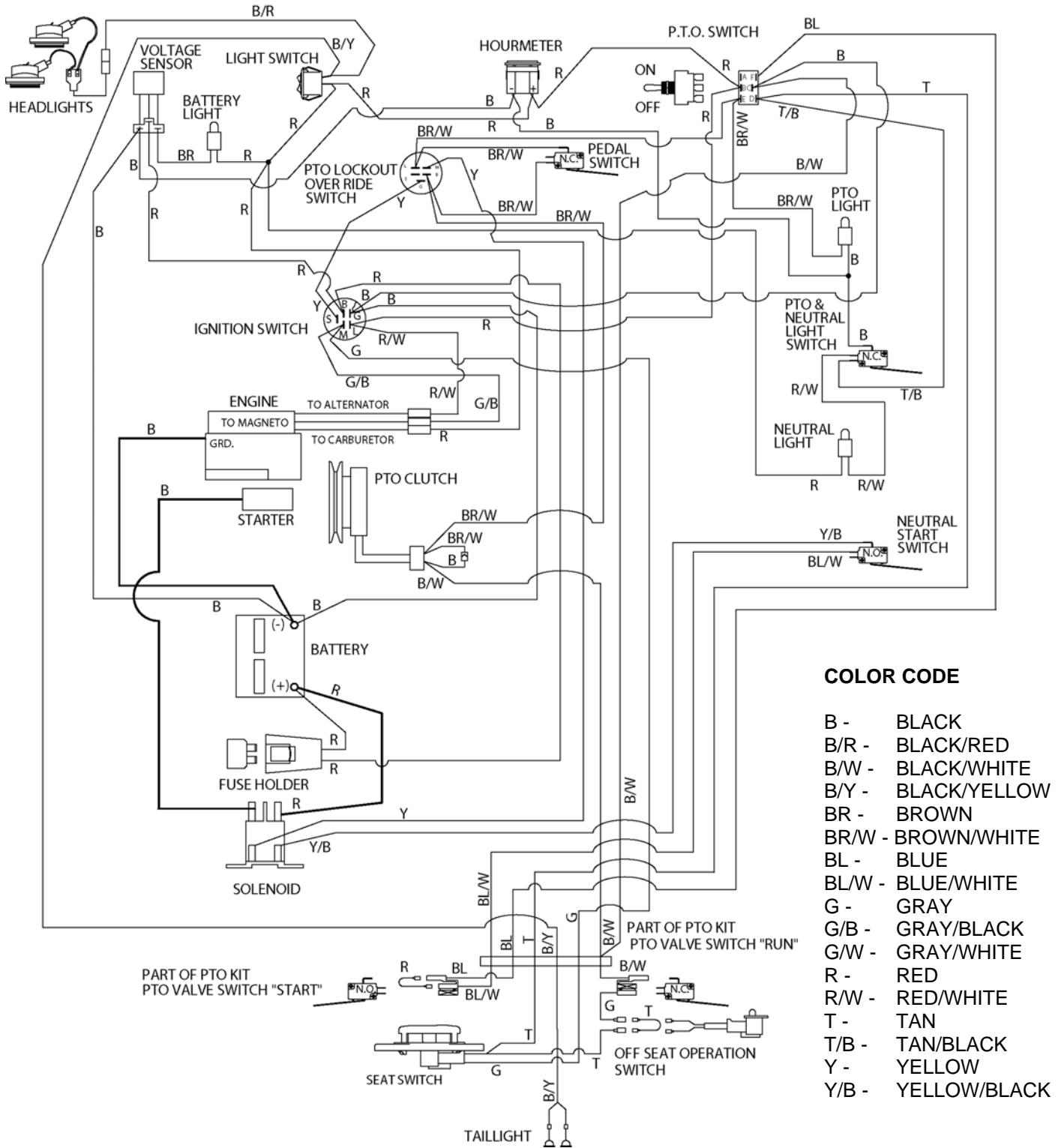

FIGURE 14

4000 SERIES WIRING DIAGRAM

With Rear Chassis PTO Wire Harness

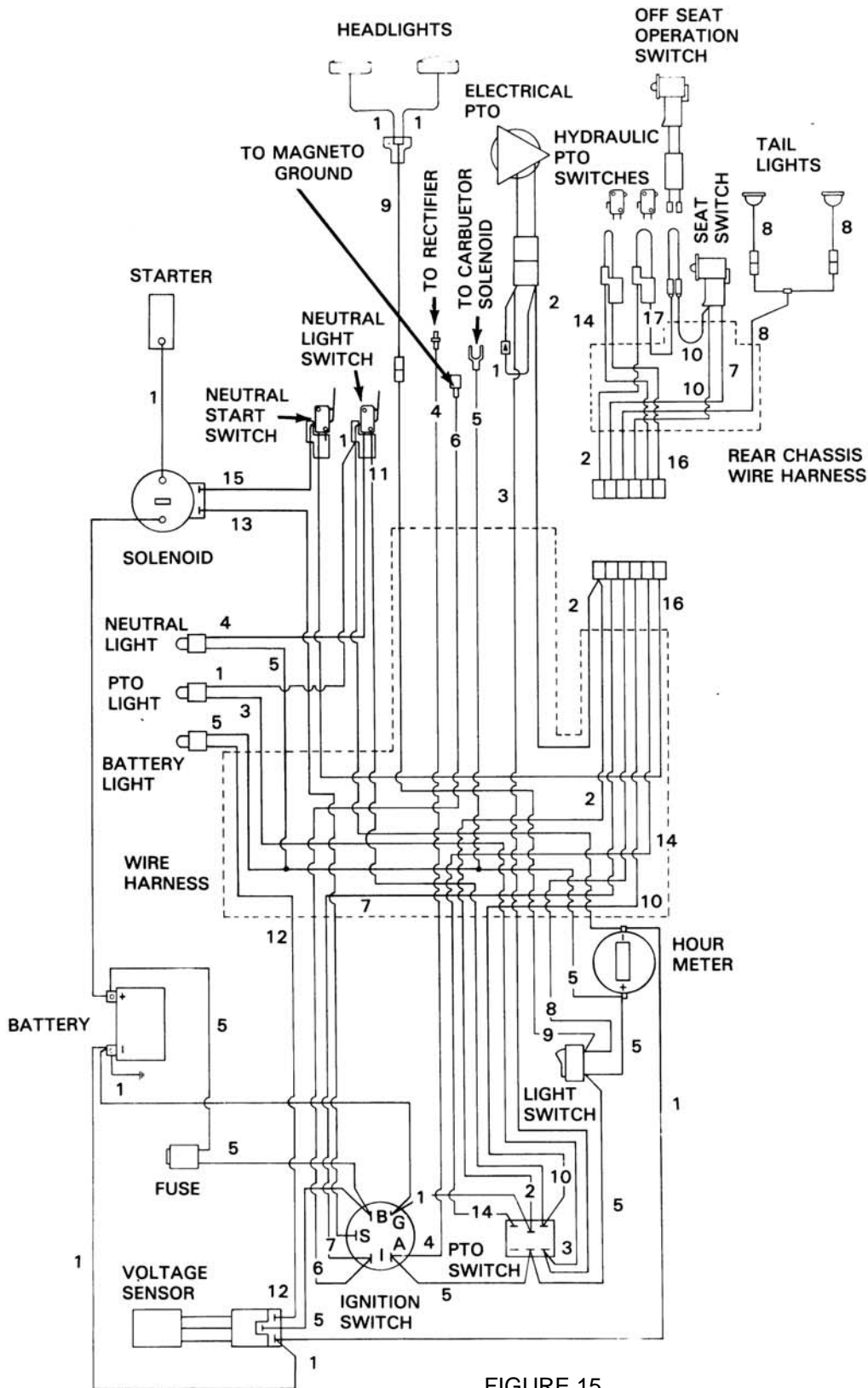

FIGURE 15

COLOR CODE

- 1. Black
- 2. Black w/white
- 3. Brown w/white
- 4. Red w/white
- 5. Red
- 6. Gray w/black
- 7. Gray
- 8. Black w/yellow
- 9. Black w/red
- 10. Tan
- 11. Tan w/black
- 12. Brown
- 13. Yellow
- 14. Blue
- 15. Yellow w/black
- 16. Blue w/white
- 17. Lite Green

BATTERY



CAUTION: When removing a battery, always disconnect the (-) negative ground cable first. When installing the battery, always connect the (-) negative ground cable last.



CAUTION: Never wear rings or metal watchbands when working with the tractor electrical system or battery as you may ground a live circuit.

Your tractor is equipped with a sealed battery requiring no maintenance.

CABLE TERMINALS AND BATTERY POSTS

Keep the battery terminals clean and tight.

1. Remove all corrosion with a wire brush.
2. Wash with a neutral solution.
3. Apply a thin layer of light grease to prevent corrosion.

IDLE BATTERY

When the tractor is not used regularly, the battery will slowly lose voltage. Charge the battery at regular intervals to keep the battery voltage above 10.5 volts. A battery with voltage below 9.5 volts can freeze and become damaged during winter weather.



DANGER: Batteries produce explosive charges. Keep sparks, flame and cigarettes away. Ventilate when charging or using in enclosed space. Always shield eyes when working near batteries.



CAUTION: When working around storage batteries, remember that all of the exposed metal parts are “live”. Never lay a metal object across the terminals as a spark or short circuit may result. Sparks, lighted matches and exposed flames must be kept away from the battery due to the presence of explosive gas in the battery. The liquid in the batteries is acid. Use care not to spill it on hands or clothing.

HOW TO USE JUMPER CABLES AND A BOOSTER BATTERY

Always wear protective goggles and clothing when you work near batteries. Prevent acid from coming in contact with your skin or clothing.

Connect the jumper cables as shown below. Follow the numbers for the correct sequence of installation.

To remove the jumper cables, reverse the sequence.

To prevent any possible sparks near the battery:

1. Make sure the last connection is as far as possible from the battery.
2. Do not let the ends of the cables make contact with each other.
3. If the booster battery is on another machine, make sure machines do not make contact.

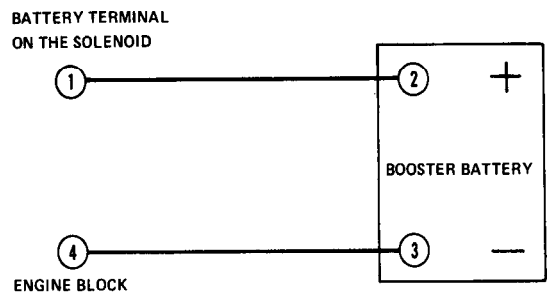

FIGURE 16



WARNING: To jumpstart this machine, connect positive jumper cable to battery terminal on starter solenoid and connect negative jumper cable to good engine ground. Start engine only when seated in operator's seat. Stop engine before leaving machine. Disconnect jumper cables. Any other method would result in uncontrolled machine movement.

HEADLIGHTS

To replace the headlight bulb:

1. Remove the two screws and retainers.
2. Remove the headlight receptacle.
3. Push in and turn counterclockwise to remove the bulb.
4. Push in and turn clockwise to install the new bulb.
5. Install the receptacle. Put one gasket between the lens and grille. Put the other gasket in the groove between the lens and the receptacle.
6. Install the retainers with the mounting screws.

NOTE: The new bulb will not illuminate until the receptacle has a ground connection.

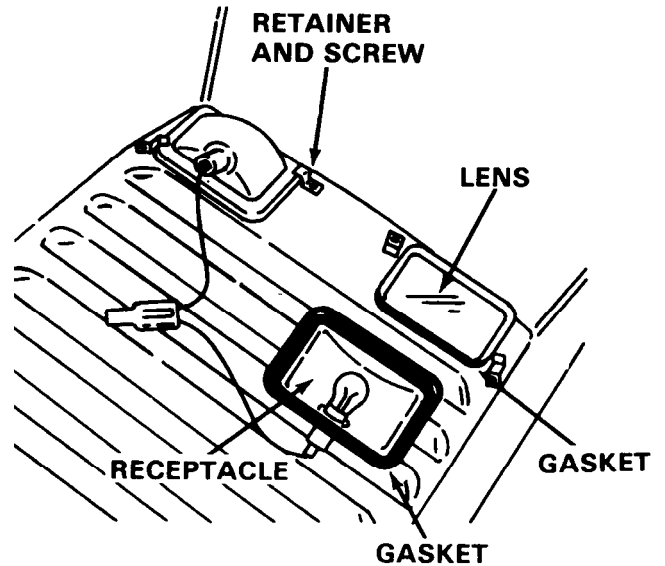

FIGURE 17

FUSE

The 30 amp fuse is located next to the hydraulic oil reservoir. This fuse protects all circuits except the starter motor.

Use the following procedure to replace a fuse:

- a. **TO REMOVE:** Hold the fuse holder while you pull up on the fuse.
- b. Inspect and clean the contacts of the fuse holder (if required).
- c. **TO INSTALL:** Push firmly into the fuse holder.

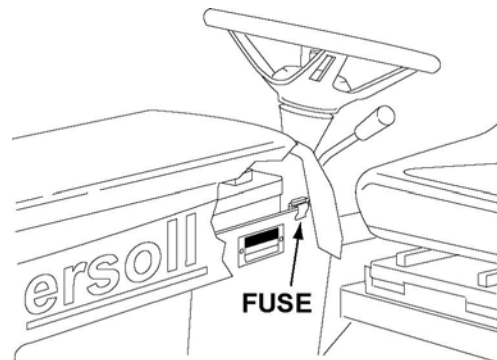

FIGURE 18

ATTACHMENT DRIVE CLUTCH BREAK-IN PROCEDURE

To insure normal clutch lining wear life, the lining must be burnished using the following procedure:

1. Install the mower or snow blower attachment.
2. Run engine at 1/2 throttle.
3. Engage and disengage clutch 5 times. 10 seconds on, 10 seconds off.
4. Increase engine speed to 3/4 throttle.
5. Engage and disengage clutch 5 more times. 10 seconds on, 10 seconds off.

BRAKE

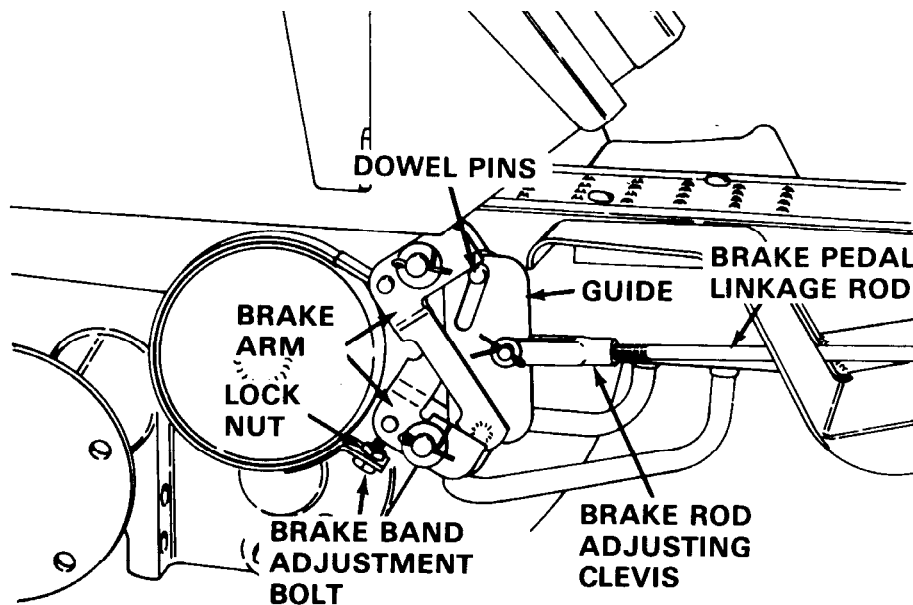

FIGURE 19

LUBRICATION

Apply several drops of oil to each pivot point on the brake linkage. Make sure no oil gets on the brake lining or the brake drum.

ADJUSTMENT

The brake is correctly adjusted when:

- a push of the pedal brings the tractor to a quick stop
- (4000 series only) the travel control lever returns automatically to the "NEUTRAL" position from both "FORWARD" and "REVERSE".

Adjust the brake if needed. Use the procedure below:

- Put the tractor on a hard, level surface, a concrete floor for example.
- Put the dual range lever in the "NEUTRAL" position.
- Release the brake.

- Remove the cotter pin, clevis pin and clevis from the guide.
- Loosen the lock nut.
- Push the guide rearward. Make contact between the dowel pins and arms.
- Tighten the adjusting bolt one half turn at a time. Push the tractor with medium force after each adjustment.
- When the tractor can not be pushed with medium force, loosen the adjusting bolt one turn. Make sure the brake drum moves freely.

NOTE: Do not permit the adjusting bolt to become too tight. This will cause distortion of the brake band.

- Tighten the lock nut.
- Hold the guide rearward.
- Turn the clevis. Align the hole in the clevis with the rear of the slot in the guide. Install the clevis, clevis pin and a new cotter pin.

FUEL

Always use clean, fresh gasoline and a funnel with a filter. Use regular no-lead gasoline with minimum octane ratings as follows:

Research Method	90
Motor Method	82
Average	87

In the United States the average octane rating is shown on gasoline pumps. In other countries, if the method is not given, it is the Research Method. No-lead fuel leaves less combustion chamber deposits. Leaded gasoline may be used only if no-lead gasoline is not available.



CAUTION: Handle gasoline with care—it is highly flammable.

a. Use approved gasoline container.

b. Never remove the cap of the fuel tank or add gasoline to a running or hot engine, or fill the fuel tank indoors. Wipe up spilled gasoline.

c. Open doors if the engine is run in the garage—exhaust fumes are dangerous. Do not run the engine



CAUTION: Never store the equipment with gasoline in the tank inside a building where fumes may reach an open flame or spark. Allow the engine to cool before storing in any enclosure.



CAUTION: Do not smoke when working near fuel.

Purchase gasoline in small quantities. Fresh gasoline reduces chance of gum deposits forming and clogging the fuel system and ensures a fuel blended for the season. Do not use gasoline left over from the previous season.

Do not add oil to the gasoline.

If a restriction of fuel occurs, replace the filter and clean the vent in the fill cap.

IMPORTANT: Damage to fuel system components will occur if gasoline containing alcohol is used. Use only regular leaded or no-lead gasoline, which does not contain alcohol. Avoid using gas line de-icer additives.

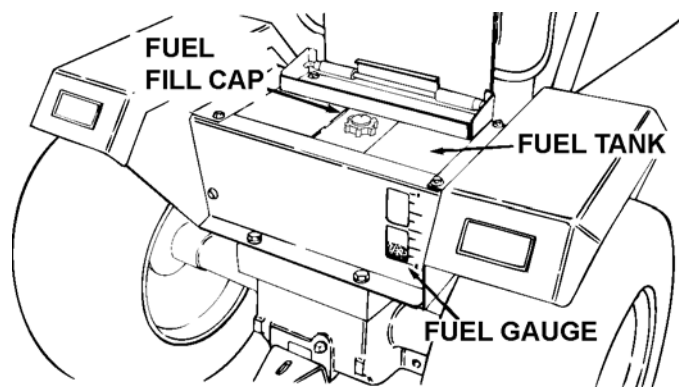
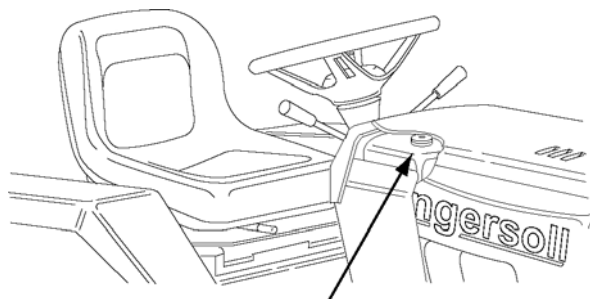

FIGURE 20

HYDRAULIC OIL



**HYDRAULIC OIL
FILL CAP**

FIGURE 21

Change the hydraulic oil after each 500 HOURS of use. Replace the hydraulic oil seasonally according to the chart below.

AIR TEMPERATURE	OIL VISCOSITY
Above 32°F (0°C)	SAE 20W40*
Below 32°F (0°C)	SAE5W20*

*Use API Service Classification SE or CC.

Ingersoll Custom Blend motor oil is recommended. This oil is a special blend for hydraulic applications.

The oil level must be kept 5" to 6" (120 mm to 150 mm) down from the top of the filler neck.

Use the following procedure to drain the hydraulic system:

1. Remove the spark plug(s) from the engine.
2. Ground the spark plug wire(s) to the engine block.
3. Place an oil drain pan with a capacity of two gallons under the travel control valve.
4. Remove the 1/4" hex socket plug.
5. Crank the engine to "pump" the oil out the drain hole.
6. Install the drain plug, spark plug(s) and wire(s).
7. Fill the reservoir to 5" to 6" (120 mm to 150 mm) from the top of the filler neck.
8. Run the engine and (a) drive forward and reverse a short distance and (b) raise and lower the hydraulic lift two times. Check the oil level again.

IMPORTANT: Make sure oil reservoir is filled to the proper level. Overfilling will cause oil leakage. Under filling will cause cavitation and intermittent drive.

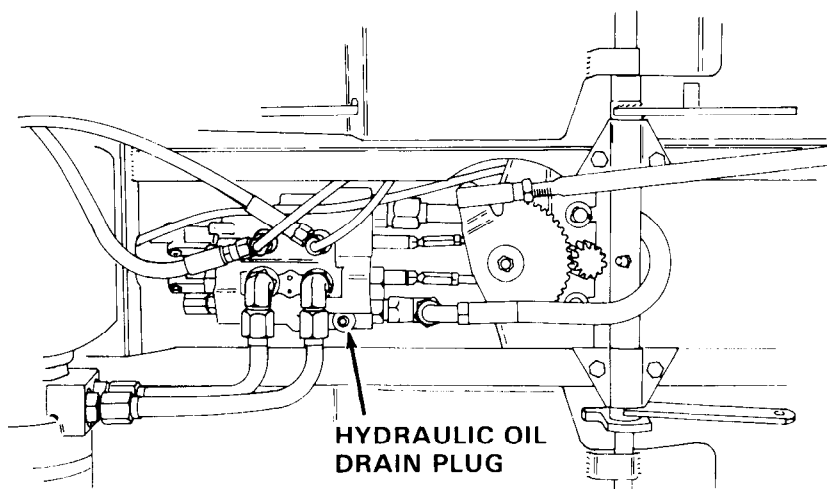

FIGURE 22

HYDRAULIC OIL COOLER

The hydraulic oil cooler must be kept clean and unobstructed at all times.

Check the hydraulic oil cooler DAILY before operating your tractor and frequently during use.

If debris builds up on the screen during tractor operation, STOP the tractor engine immediately and clean the debris off.

An obstructed hydraulic oil cooler can cause the tractor hydraulic system and engine to overheat and fail prematurely.

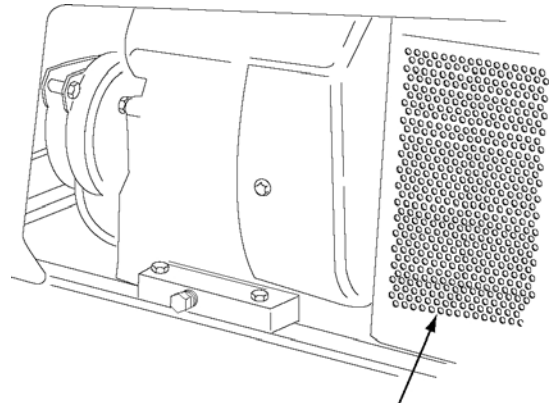

HYDRAULIC OIL COOLER

FIGURE 23

HYDRAULIC OIL FILTER

The hydraulic oil system is protected by an oil filter.

The hydraulic oil filter is located behind R.H. air screen on tower.

Replace oil filter after every 500 hours of use, when you change hydraulic oil. Replace more often if oil becomes contaminated.

To replace hydraulic oil filter:

1. Remove R.H. air screen on tower.
2. Use suitable size filter wrench to loosen filter.
3. Apply clean oil to gasket of new filter.
4. Install filter manually until tight.
5. Tighten filter one full turn with wrench.
6. Check filter for leaks after you fill the hydraulic system. (See Hydraulic Oil Section.)
7. Install R.H. air screen.

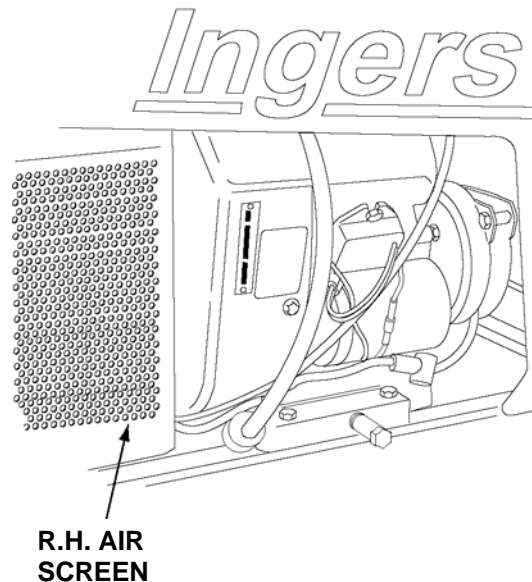

R.H. AIR SCREEN

FIGURE 24

SEAT

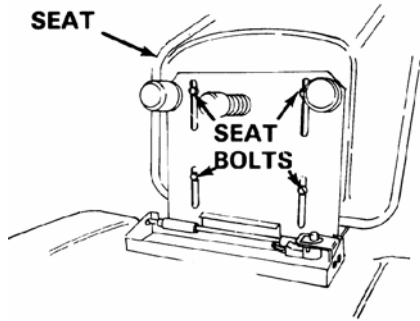

FIGURE 25

ADJUSTMENT

If your seat is not equipped with an adjustment lever follow this procedure:

1. Loosen the four bolts that hold the seat to the seat hinge.
2. Move the seat either forward or rearward to get the correct position on the seat hinge.

3. Tighten the bolts.

MAINTENANCE

1. Clean the seat regularly. Use a special vinyl cleaner. Do not use a solvent as this will damage the seat.
2. Severe heat or cold can damage the seat. Protection from these conditions is important. Put a cover on the seat for protection against weather conditions and water. It is best to put the tractor in a building when not in use.
3. During operation in severe weather conditions, you can easily damage the seat. Be careful not to damage the seat when you get on and off the tractor.
4. If the seat gets a small tear, apply a vinyl repair tape over the damaged area. Black vinyl repair tape can be purchased locally.

TRANSAXLE

Change the oil in the transmission after each 500 HOURS of operation.

The oil drain plug is located on the right hand side of the transaxle housing.

The oil level check plug is located on the right hand side of the transaxle housing just above the drain plug.

The oil fill plug is located on the rear of the transaxle housing.

AIR TEMPERATURE

OIL TYPE & VISCOSITY

All Temperatures

API Service Class SE or CC
SAE 20W40 or
SAE 80 EP Gear Lube

Capacity One Pint (.5 l).

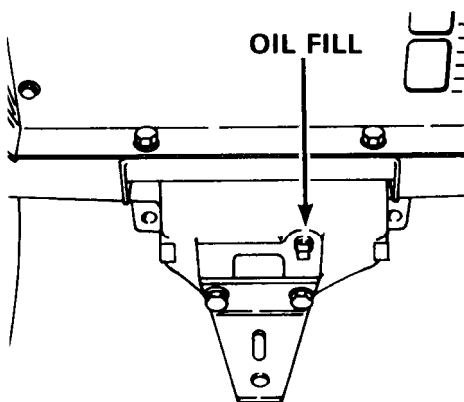

FIGURE 26

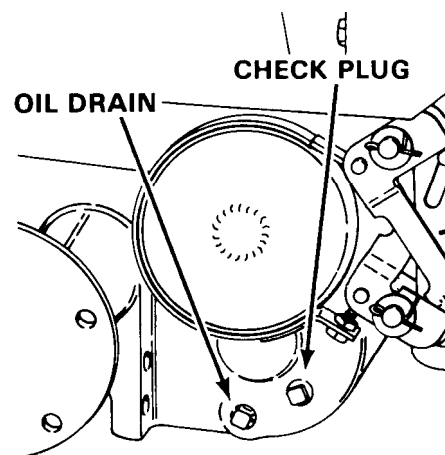

FIGURE 27

CHASSIS LUBRICATION

Apply grease after every 25 HOURS of operation to the:

- a. front wheel spindles

NOTE: Lift front of tractor to permit grease to flow from top and bottom of spindle.

- b. front wheel bearings

NOTE: Remove dust caps from front wheel hubs before greasing front wheel bearings. The trapped air behind the dust caps can prevent the full lubrication of the bearings.

- c. axle pivot pin

- d. steering gear - apply a small amount of grease to the gear teeth

- e. lift shaft

Use number 1 multi-purpose grease (Lithium Base) for all lubrication fittings. Use as many strokes as required, until you see grease pushing out of assembly.

Always wipe dirt from fitting before applying the grease gun.

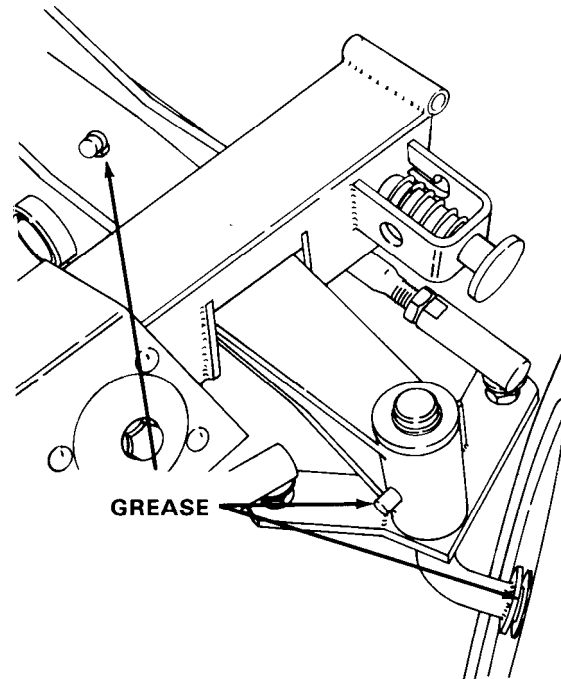

FIGURE 28
Front Wheel Spindle Bearings and Axle Pivot Pin

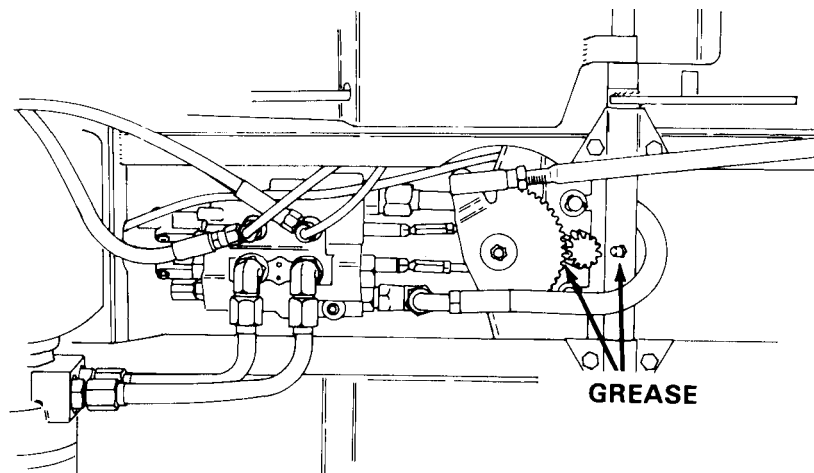

FIGURE 29 Steering Gear and Lift Shaft

STEERING ADJUSTMENT



CAUTION: When adjusting steering wheel free play, make certain that some free play remains between the sector gear and pinion gear. A tight fit, with no clearance between the two gears, may cause binding and tooth failure.

IMPORTANT: Check for loose or worn ball joints, drag link, or tie rod before adjusting the steering gear. Tighten or replace these components as required.

The tractor is assembled with shim washers between the steering gear and the support bracket. See the illustration. When the gear teeth wear, more free movement occurs. If too much free movement occurs adjust the steering gear.

1. Disconnect the drag link from the steering gear.
2. Remove the nut securing the steering gear.
3. Remove the steering gear.
4. Remove one or more shim washers from above the steering gear.
5. Put the steering gear in place on the pivot shaft.

6. Put the shim washers, washers and the nut on the steering gear bolt and tighten securely. The total number of the shim washers must always be the same.

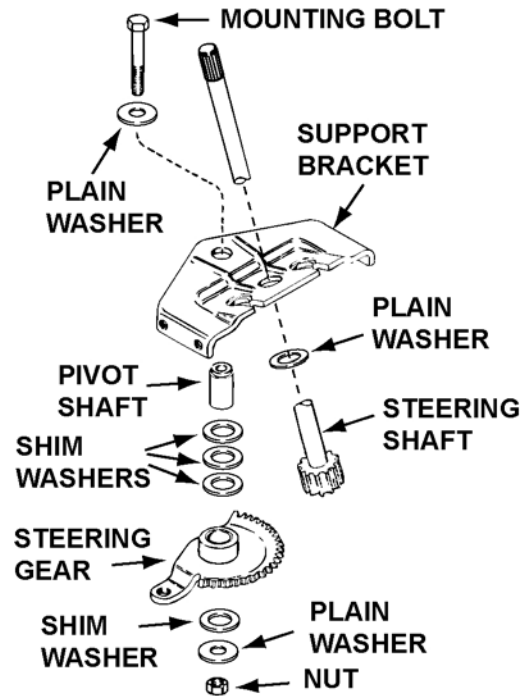

FIGURE 30

TOE-IN ADJUSTMENT

1. Put the tractor on a hard and level surface like a concrete floor.
2. Make sure the front tires have equal air pressure.
3. Find the centerline of the front tires. See the figure below.
4. If you can not find the centerline:

a. raise the front wheels off the ground

b. spin each wheel and put a mark at the centerline with chalk

5. Measure the distance between each centerline or chalk mark.

Measurement "A" must be 1/8 to 3/8" (3.2 mm to 9.5 mm) less than measurement "B".

Both measurements, front and rear, must be taken at spindle height above the floor.

6. Loosen both lock nuts on the tie rod.

NOTE: Do not remove the ball joints from the king pins. Turn the tie rod to change the toe-in.

7. Turn the ball joints off of the tie rod to decrease the toe-in.
8. Turn the ball joints onto the tie rod to increase the toe-in.

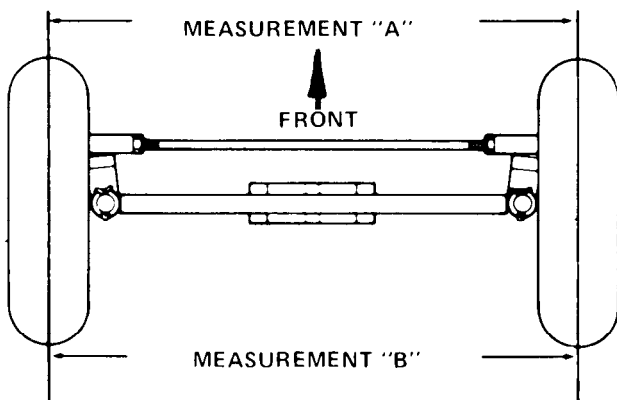

FIGURE 31

MANUAL ORDERING PROCEDURE

These manuals are available from the Ingersoll Tractor Co.

- a. Parts Manual (includes part numbers and exploded views of your equipment assemblies).
- b. Operator's Manual (includes specifications, operating procedures and maintenance procedures for your equipment).
- c. Service Manual (includes repair procedures for your tractor).

To make sure you receive the correct manuals, always have the following numbers available:

Tractor Model No. _____

Tractor Serial No. _____

Attachment Model No. _____

Attachment Serial No. _____

Each attachment usually has a separate parts manual and Operator's Manual. They are not included with the tractor.

To place an order:

1. Call your local dealer or
2. Contact: Ingersoll Tractor Company
70 Ingersoll Drive
Portland, Maine 04103

Attention: Manual Order

Phone: 1-800-760-1680

All orders will include charges for postage, handling and C.O.D. if applicable.

Prices are subject to change without notice. Contact us for current prices.

Please allow 2-3 weeks for delivery.

