

**Ingersoll**

**SWEeper**  
**SW38, S90, R90, P90, N90, M90**  
**Operator's Manual 9-51248**

[casecoltingersoll.com](http://casecoltingersoll.com)

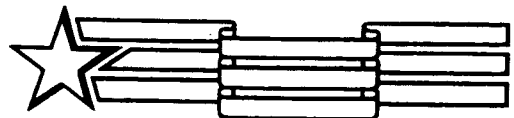

**QUALITY IN THE AMERICAN TRADITION**

**Ingersoll Equipment Co., Inc.**

**Winneconne, Wisconsin 54986-9576**



This Safety Alert Symbol Indicates Important Safety Messages In This Manual When You See This Symbol Carefully Read The Message That Follows and Be Alert To The Possibility Of Personal Injury Or Death

IF THIS MACHINE IS USED BY AN EMPLOYEE OR IS LOANED OR RENTED, MAKE ABSOLUTELY CERTAIN THAT THE OPERATOR(S), PRIOR TO OPERATING:

1. IS INSTRUCTED IN SAFE AND PROPER USE.
2. REVIEWS AND UNDERSTANDS THE MANUAL(S) PERTAINING TO THE MACHINE.

751253



# WARNING

## BEFORE STARTING ENGINE

STUDY OPERATOR'S MANUAL SAFETY MESSAGES  
READ ALL SAFETY SIGNS ON MACHINE  
CLEAR THE AREA OF OTHER PERSONS

## LEARN & PRACTICE SAFE USE OF CONTROLS BEFORE OPERATING

IT IS YOUR RESPONSIBILITY TO UNDERSTAND AND FOLLOW MANUFACTURER'S INSTRUCTIONS ON MACHINE OPERATION, SERVICE, AND TO OBSERVE PERTINENT LAWS AND REGULATIONS. OPERATOR AND SERVICE MANUALS MAY BE OBTAINED FROM YOUR EQUIPMENT DEALER.

## SAFETY MESSAGES



The safety rules contained in this manual are to be used together with the safety rules appearing in the tractor operator's manual. Be sure to review both manuals carefully before operating the tractor-sweeper combination.



**CAUTION:** Put tractor in neutral, stop engine and set parking brake before leaving tractor seat to:

1. Hook or unhook sweeper
2. Unplug sweeper brushes
3. Adjust sweeper height
4. Empty sweeper basket or for any other reason.



**CAUTION:** Before hanging sweeper for storage, make absolutely certain the wall and hooks or nails are of sufficient capacity to support the sweeper which weighs 125 pounds (56.5 kg).

### IMPORTANT:

Always install new decals whenever the old decals are destroyed, lost, painted over or illegible. When individual parts are replaced that have decals attached, be sure to install a new decal with the new part. Replacement decals are available from your dealer.



**CAUTION:** Your sweeper may throw debris as far as the tractor operator's position. To reduce the possibility of injury to the operator, the following rules must be observed:

1. Wear safety glasses (with side shields) at all times while sweeping.
2. Regulate ground speed so the path of debris terminates at the front inside edge of the hopper.
3. Adjust sweeper height to the transport position whenever crossing roads or driveways. Always cross these areas at very slow speeds.



**CAUTION:** DO NOT empty sweeper hopper, drive sweeper close to, or back up to, an open fire. Sweeper hopper contents and sweeper brushes are flammable and may ignite resulting in possible personal injury or property damage.

The Ingersoll Equipment Co., Inc. reserves the right to make improvements in design or changes in specifications at any time without incurring any obligation to install them on units previously sold.

## INTRODUCTION

The Lawn Sweeper is designed for use with most makes of compact tractors and riding mowers with a drawbar. Read this manual carefully before operating your sweeper. The

terms right, left, front and rear refer to the sweeper when seated on the tractor seat facing the normal direction of forward travel.

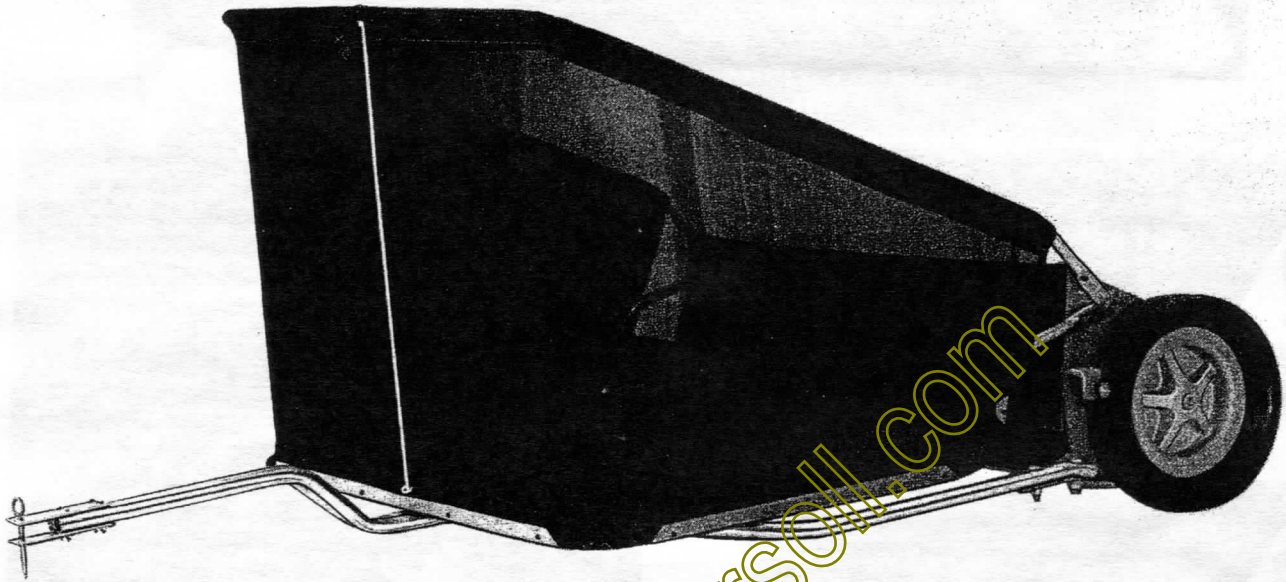

Figure 1 Lawn Sweeper

## OPERATION

### PREPARATION

The area to be swept should be cleared of all large twigs, sticks, and objects which might plug or be thrown by the sweeper. Small twigs may be swept if approached in a direction parallel with the brushes.

- CAUTION:** Your sweeper may throw debris as far as the tractor operator's position. To reduce the possibility of injury to the operator, the following rules must be observed:
1. Wear safety glasses (with side shields) at all times while sweeping.
  2. Regulate ground speed so the path of debris terminates at the front inside edge of the hopper.
  3. Adjust sweeper height to the transport position whenever crossing roads or driveways. Always cross these areas at very slow speeds.



The second hole from the top is the highest sweeping position; the bottom hole is the closest sweeping position with four intermediate sweeping positions. Make sure the height selector pin is fully engaged in the desired hole before operating.

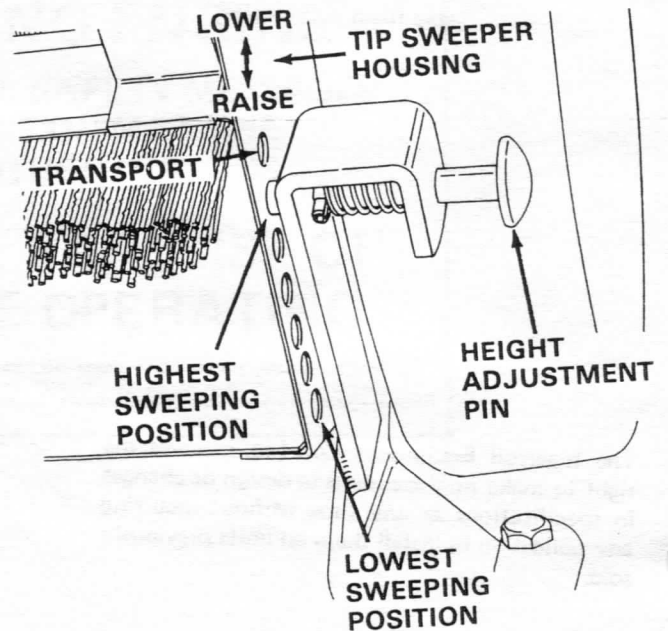

Figure 2 Height Adjustment Lever

### HEIGHT ADJUSTMENTS

The height adjustment selector has seven holes. The top hole is the transport position. The transport position should be used whenever crossing drives or roadways, when transporting long distances or crossing areas that sweeping is not desired.

## SWEEPING

For best sweeping performance, observe the following guidelines:

1. Terrain must be relatively even. Always mow just prior to sweeping. Leaves will actually pick up easier and cleaner if they are first partially mulched by a mower. Leaves that have imbedded in the turf are very difficult to pick up. Mowing lifts imbedded materials and makes them easier to pick up.
2. Before sweeping, pick up all tree branches, etc. too large to be picked up by the sweeper as they can lodge in the brush mechanism and cause wheel slippage. The metal skid pan (See Fig. 6) which is under the full width of the sweeper protects it from rocks and protruding objects.

It will also spread a large pile of debris on the first pass so clean up may be accomplished in successive passes without clogging the sweeper.

3. Adjust height so the first stage brushes are in "light" contact with the turf. A suggested technique is to first set the height low enough to encounter slight or occasional wheel slippage, then raise the adjusting lever one notch. When sweeping a pile of debris, adjust to maximum height, the skid pan will spread the pile and will allow the brushes to pick up more debris than if set at a lower position.

4. Since all of this sweeper's weight is on the drive wheels, providing very positive drive power to the brushes, optimum pick up and propelling of debris to front of the hopper does not require high ground speed. Slower ground speeds should be used when sweeping high density material, such as, twigs, nut shells, tree fruit, etc., than when sweeping light, dry grass and leaves. Regulate the tractor ground speed so that the brushes propel the material to the front of the hopper without going over the top. This will deliver a full hopper and fewer dump cycles will be required. Never exceed low range ground speeds under any condition. Normally when sweeping, one-third to three-quarter engine throttle setting is adequate. Lower engine speeds also reduce fuel consumption and produce quieter operation of the tractor.

5. Should wheel slippage occur suddenly while sweeping, check the brushes for a lodged twig and check the shroud point where the first and second stage brushes intersect for a lodged clump of grass or leaves. If a clump of leaves or grass is found in this area, it can be easily removed by manually turning the brushes in the reverse direction.

## EMPTYING HOPPER

The hopper is emptied by pivoting it over the back of the sweeper unit. Polypropylene brushes will melt or burn when exposed to intense heat or open flame. Be sure to keep a safe distance from piles of burning leaves or other sources of intense heat. Do not back-up to piles of burning leaves.



**CAUTION:** DO NOT empty sweeper hopper, drive sweeper close to, or back up to, an open fire. Sweeper hopper contents and sweeper brushes are flammable and may ignite resulting in possible personal injury or property damage.

PIVOT HOPPER  
AROUND THIS  
POINT TO EMPTY

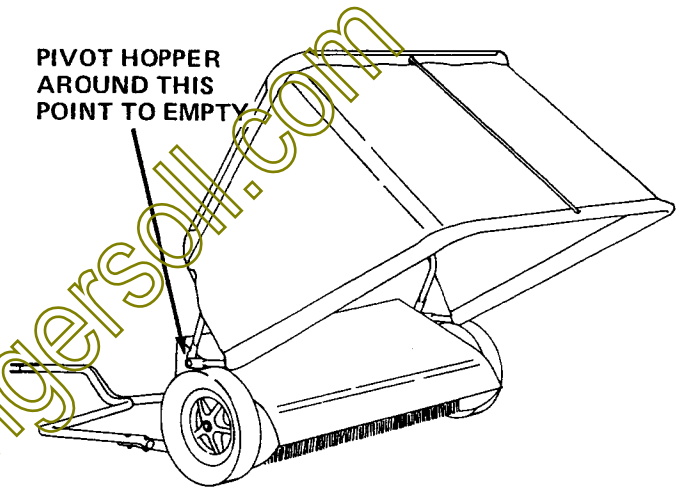

Figure 3 Emptying the Hopper

**IMPORTANT:** Avoid making short turns and use care when backing. The rear tractor tires may contact the sweeper tow-bar causing damage, when very short turns are made.

**CAUTION:** Put tractor in neutral, stop engine and set parking brake before leaving tractor seat to:

1. Hook or unhook sweeper
2. Unplug sweeper brushes
3. Adjust sweeper height
4. Empty sweeper basket or for any other reason.



## STORAGE

Before storing the sweeper, it should be thoroughly cleaned and any scratches or scuffed surfaces repainted. Store in a dry, weather protected location.

The sweeper may be hung on a garage wall or other suitable area for convenient storage.

Remove the hopper from the sweeper housing assembly and the rod from the hopper and fold the hopper flat. The sweeper should then be hung by its tow bar on suitable large nails or hooks. The flattened hopper should be secured to the sweeper after hanging.

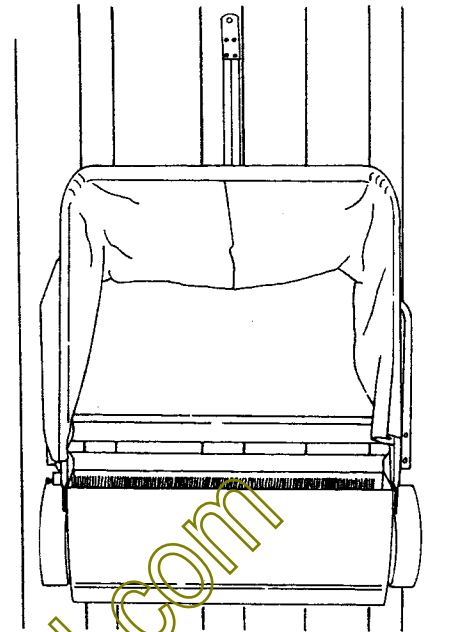

Figure 4 Sweeper Shown in its Recommended Storage Position

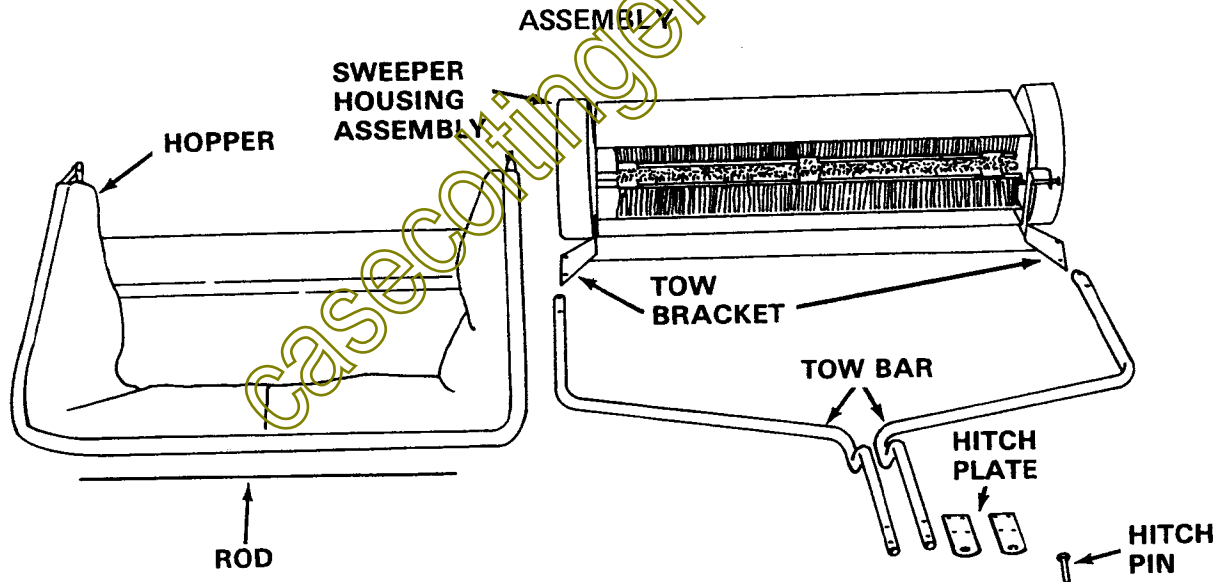
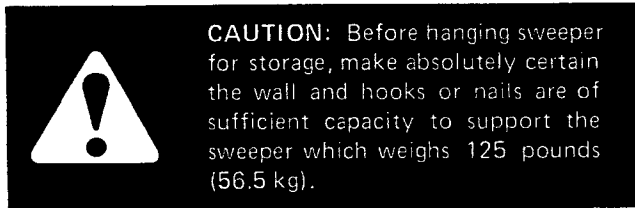

Figure 5 Sweeper - Disassembled (See Figure 1 for Illustration of Assembled Sweeper)

Your sweeper has been completely pre-assembled with the exception of the tow-bar and installation of the Hopper.

The tow-bar should be positioned on top of the tow brackets and the bolts installed from the top. The bolts should be secured with the lockwashers and nuts provided.

Tighten after complete assembly.

Assemble the tow bar by placing a hitch plate on the top and bottom of the forward end as shown positioned in

FIGURE 5. Insert four bolts from the top and secure with lock nuts.

Insert the rod through the eyelet in the hopper fabric and into the hole in the lower frame tube. Lift the upper frame tube, bow the prop rod and insert it through the eyelet in the hopper fabric and into the hole in the upper frame tube. The rod may remain slightly bowed when first installed.

The Hopper should then be inserted in the slotted hopper retainers (Figure 6) in the Sweeper Housing Assembly.

## MAINTENANCE

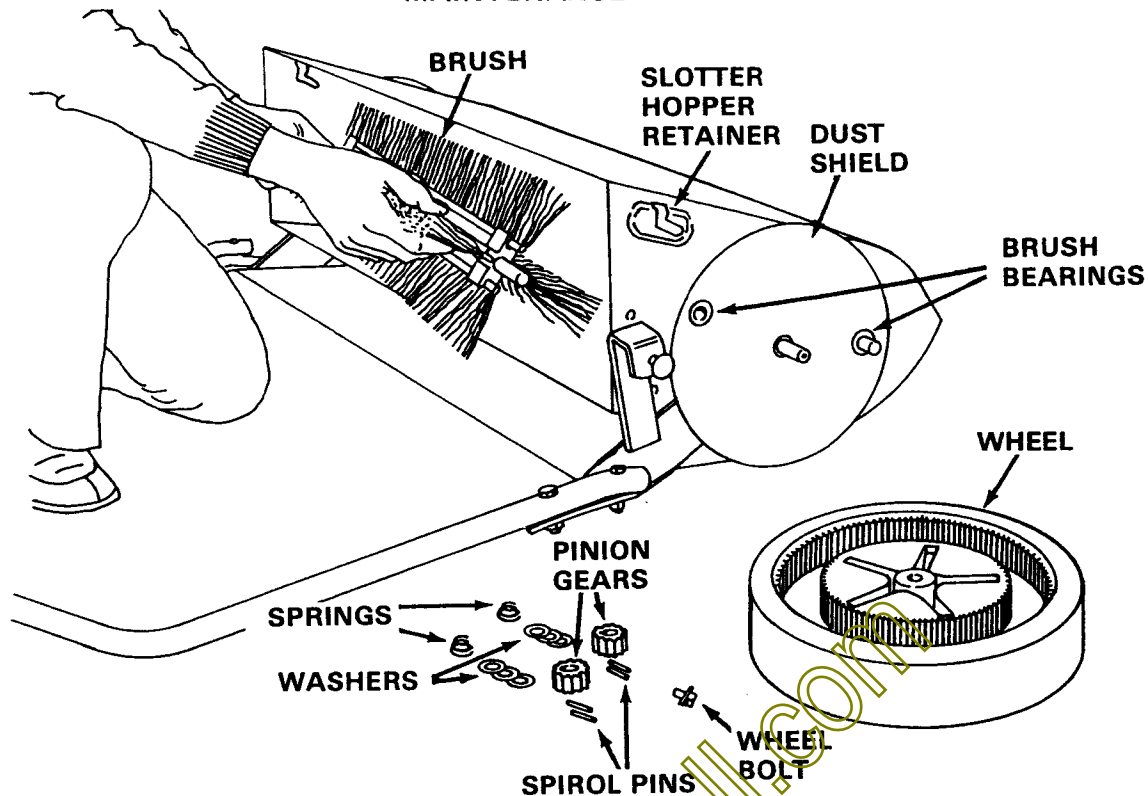

Figure 6 Removing Brush (Left Side Only Shown for Clarity)  
Drive Wheel and Gears Removed

## BRUSH REPLACEMENT

The pickup brush and propeller brush are identical. If noticeable wear is evident on the pickup brush, it may be interchanged with the propeller brush to increase sweeping efficiency. The sweeper should be taken to your dealer for brush replacement.

Brushes should be replaced according to the following procedure:

1. Remove wheel, spirol pins, pinion gears, springs and washers from both sides of sweeper.
2. a. For R90, P90 and N90 Sweeper with pressed in brush bearings.

To remove pickup brush:

1. Use a suitable punch to remove brush bushing from left side of sweeper housing.
2. Grasp brush and slide to left side until right end clears sweeper housing.
3. Tip brush to clear housing and pull brush out.

To remove propeller brush:

1. Use a suitable punch to remove brush bushing from right side of sweeper housing.

2. Grasp brush and slide to right side until left end clears sweeper housing.

3. Tip brush to clear housing and pull brush out.

- b. For M-90, S90 and SW38 Sweeper with bolt on brush bearings.

1. Grasp brush and slide to left side (for pickup brush) or to right side (for propeller brush) until brush end clears sweeper housing.

2. Tip brush to clear housing and pull brush out.

3. Replace brush by reversing the above procedure. Note that the brush is slightly offset on the shaft. Be sure to position the longer shaft end of the brush in the side opposite the height selector lever for propeller brush and toward height selector for pickup brush.

4. R90, P90 and N90 Sweeper Bearing Installation

- a. Install bearing over brush shaft with bearing flange to the outside.

- b. Use a suitable punch to drive the bearing into the sweeper housing.

5. The spirol pins, springs, washers and pinion gears must be installed as illustrated (Figure 7A and 7B) to function properly.

6. Refer to Step 3 - Lubrication.

## LUBRICATION

After each 10 hours of use:

1. The four sweeper brush bearings should be inspected and lubricated with a light coating of a dry lubricant such as chain and cable lubricant.
2. The wheels should be removed, the gears, pinions, and axles should be cleaned and lubricated with a light coating of a dry lubricant.
3. When replacing wheels, be sure to pilot the dust shield on the axle spacer and to align the brush drive gear teeth with the drive wheel teeth.

**IMPORTANT:** The wheel must slide freely onto shaft and gears. Forcing the wheel on with the wheel bolt will damage the drive mechanism.

casecoltingersoll.com



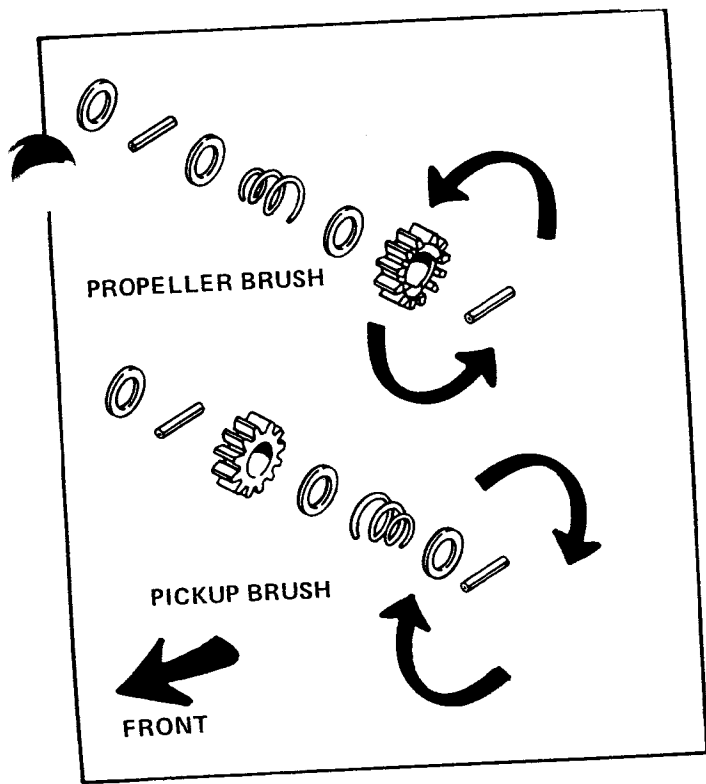

Figure 7A Correct Gear Installation  
Left Side (Height Selector Side)

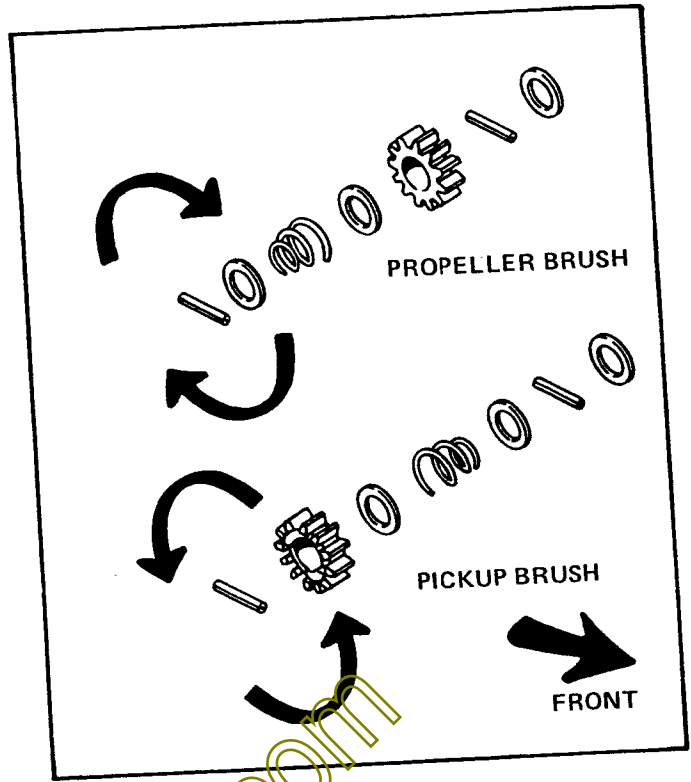

Figure 7B Correct Gear Installation  
Right Side

NOTE: Spiral pins must project equally from each side of shaft to avoid contact with drive wheel gears.

### SPECIFICATIONS

Sweeping Width .....	38" (950 mm)
Width Overall .....	45" (1150 mm)
Height Overall .....	35" (900 mm)
Length Overall .....	71" (1800 mm)
Wheel Diameter W/Tire .....	12-1/2" (315 mm)
Tire Width .....	3" (75 mm)
Hopper Capacity .....	11.9 Bu. (1.03 m <sup>3</sup> )
Weight .....	125 lbs. (56.5 kg)
Height Adj.....	Single lever - 7 positions

casecoltingersoll.com