



**DUMP CARTS**  
**E60, F60 AND E62**  
**E65 EXTENSIONS**  
**DC1000**  
**Parts Catalog 8-1870**

[HOME](#)

[TRACTORS](#)

[ATTACHMENTS](#)

[PAINT](#)

[GENERAL INFO](#)

### ALPHABETICAL INDEX

Model E60 Dump Cart .....	5
Model F60 Dump Cart.....	7
Model DC1000 Dump Cart.....	7
Model E62 Dump Cart .....	9
Model E65 Dump Cart Extensions.....	11
Model F66 Conestoga Cover .....	13

[casecoltingersoll.com](http://casecoltingersoll.com)

**INDEX**

There is an index at the front of this catalog. The front index is an alphabetical index of the major groups or assemblies.

**ILLUSTRATION**

Each illustration in this catalog shows a group of parts or components. These parts and components are aligned approximately as the parts and components on your machine. Each part and component in an illustration has a reference number. These reference numbers are in a list on the page opposite of the illustration. Next to the reference number is the part number, description and required quantity of the part shown in the illustration.

UAR - "Use as required" indicates that the part quantity is variable.

NSS - "Not sold separately" indicates that the part is only available as component of an assembly or the part must be purchased locally. If the part is an assembly component, the description will be indented under the assembly description in the parts list.

O/L - "Obtain locally"

- "Footnotes" are added to a part number when more information is needed for identification. They only relate to the part numbers indicated. All orders must include the following information:

1. Correct part number.

**PARTS ORDERS**

2. Complete description of part or component.
3. Total quantity of each part or component.
4. Product model number.
5. All necessary product identification numbers.
6. Method for sending the parts.
7. Complete and correct address.

**CATALOG REVISIONS**

As the product changes, new pages will be available for your catalog. A notice will be issued.

**IMPORTANT:** Put all revisions into the catalog as soon as possible.

**RIGHT HAND AND LEFT HAND IDENTIFICATION**

The words right hand (RH) and left hand (LH) as used in this catalog indicate the direction while you are in the operator's seat in the normal operating position.

**INDENTED DESCRIPTIONS**

An assembly can have many components. The components of an assembly are indicated by an indented description. The quantity for an indented part is the total needed for that complete assembly. See the example.

REF.	PART NO.	DESCRIPTION	REQ'D
	C 55159	CYLINDER ASSY - rear steering .....	1
28	C 56208	SOCKET ASSY - rear cylinder .....	1
29	C 55956	PLUG - adjusting, socket assy .....	1
30	C 55957	SEAT- socket, ball.....	2
31	C 56210	SPRING-socket .....	1
32	C 56209	SEAT - socket spring .....	1
33	G 45175	CLAMP ASSY - socket assy .....	1
	16- 836	BOLT-1/2"x2-1/4" N.F. hex.....	1
34	132- 104	PIN-cotter, 3/16"x3" .....	1
35	C 55889	STUD - ball, socket & cylinder .....	2
36	13- 410	BOLT-1/4"x5/8"N.C.,hex .....	4
37	92- 4	LOCK WASHER - 1/4"SAE .....	4

**INDEX**

**PAINT AND OIL**

**PAINT**

REF.	PART NO.	DESCRIPTION	REQ'D
1	C 28849	BLACK - semi - gloss, 12 oz spray (2 per carton) .....	1
2	C 28850	BLACK - semi - gloss, quart (2 per carton) .....	1
3	C 28850	BLACK - semi - gloss, heat resistant, 12 oz spray (2 per carton) .....	1
4	C 28484	POWER RED - gloss, 12 oz spray (2 per carton) .....	1
5	C 28485	POWER RED - gloss, quart (2 per carton) .....	1
6	C 30870	SILVER - gloss, 12 oz. spray (2 per carton) .....	1
7	C 31643	POWER RED - gloss, 1 oz touch up, (1 doz. per carton) .....	1

**OIL**

1	C 32776	OIL - SAE 30, SF, quart (12 per case) .....	1
2	C 32777	OIL - SAE 5W20, SF, quart (12 per case) .....	1
3	C 32778	OIL - SAE 20W40, SF, quart (12 per case) .....	1

casecoltingersoll.com

INDEX

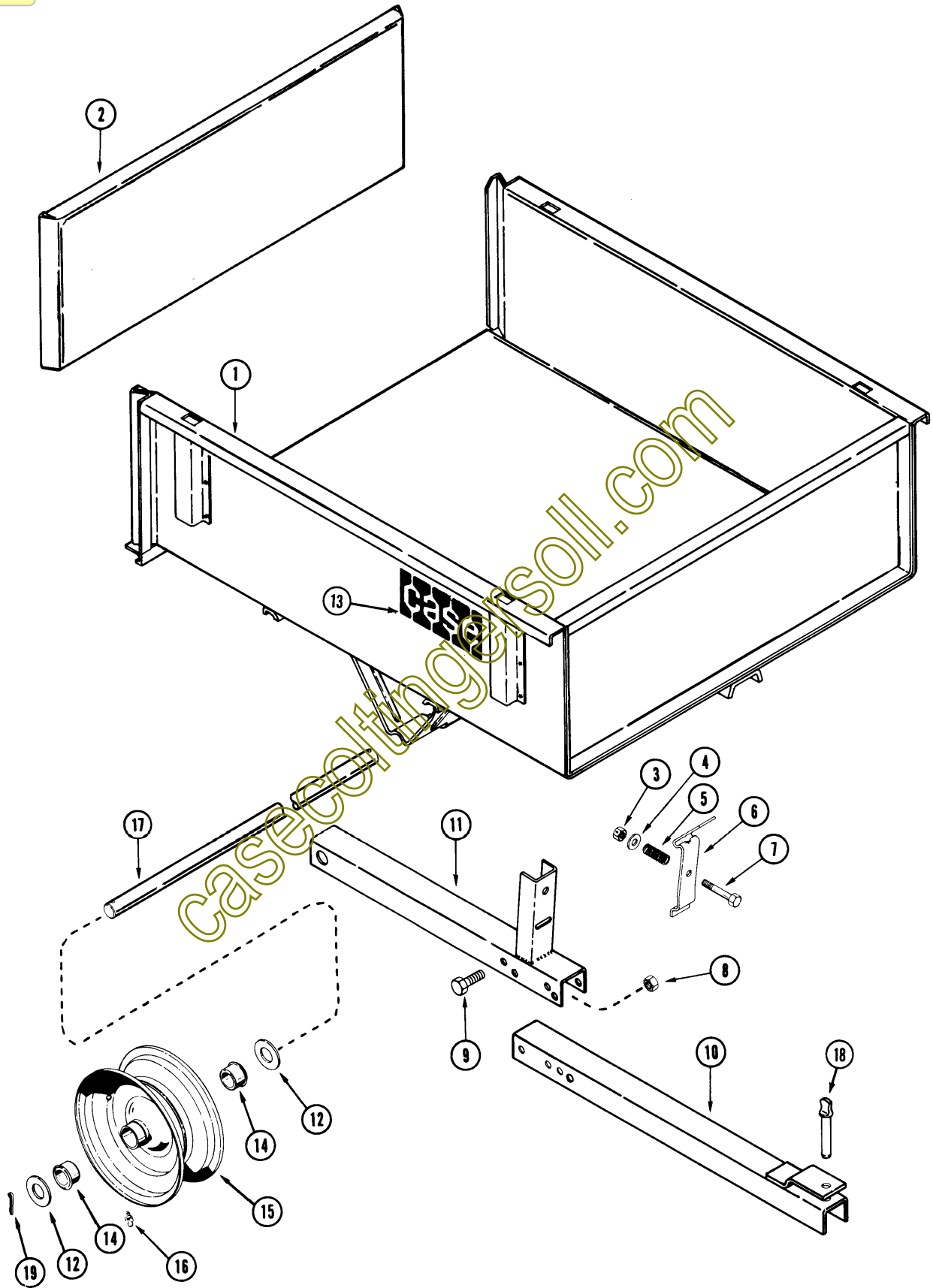

**INDEX**

**MODEL E60 DUMP CART**

REF.	PART NO.	DESCRIPTION	REQ'D
1	NSS	BODY .....	1
2	C13547	TAILGATE .....	1
3	131-176	NUT – lock 5/16" NC hex ZP.....	1
4	195-2027	WASHER - 11/32" ID ZP .....	1
5	C11942	SPRING - release .....	1
6	C13859	LEVER - release .....	1
7	113-111	BOLT - 5/16" x 2-1/2" NC hex ZP .....	1
8	131-1181	NUT-lock 3/8" NC hex ZP .....	4
9	113-206	BOLT - 3/8" x 3/4" NC hex ZP.....	4
10	C14072	TONGUE - front .....	1
11	C14073	TONGUE - rear .....	1
12	195-533	WASHER - plain 1" .....	4
13	321-1571	DECAL .....	2
14	C14221	BUSHING - flanged.....	2
15	C24964	RIM - wheel (3-3/4" rim width) (includes bearings) .....	2
15	C25222	RIM - wheel (2-1/2" rim width) (includes bearings) .....	2
16	219-1	FITTING - lube .....	2
17	C13920	SHAFT - axle 33-3/4" .....	1
18	C10888	PIN - hitch.....	1
19	132-306	PIN - cotter 3/16" x 1-3/4" ZP.....	2

casecoltingersoll.com

INDEX

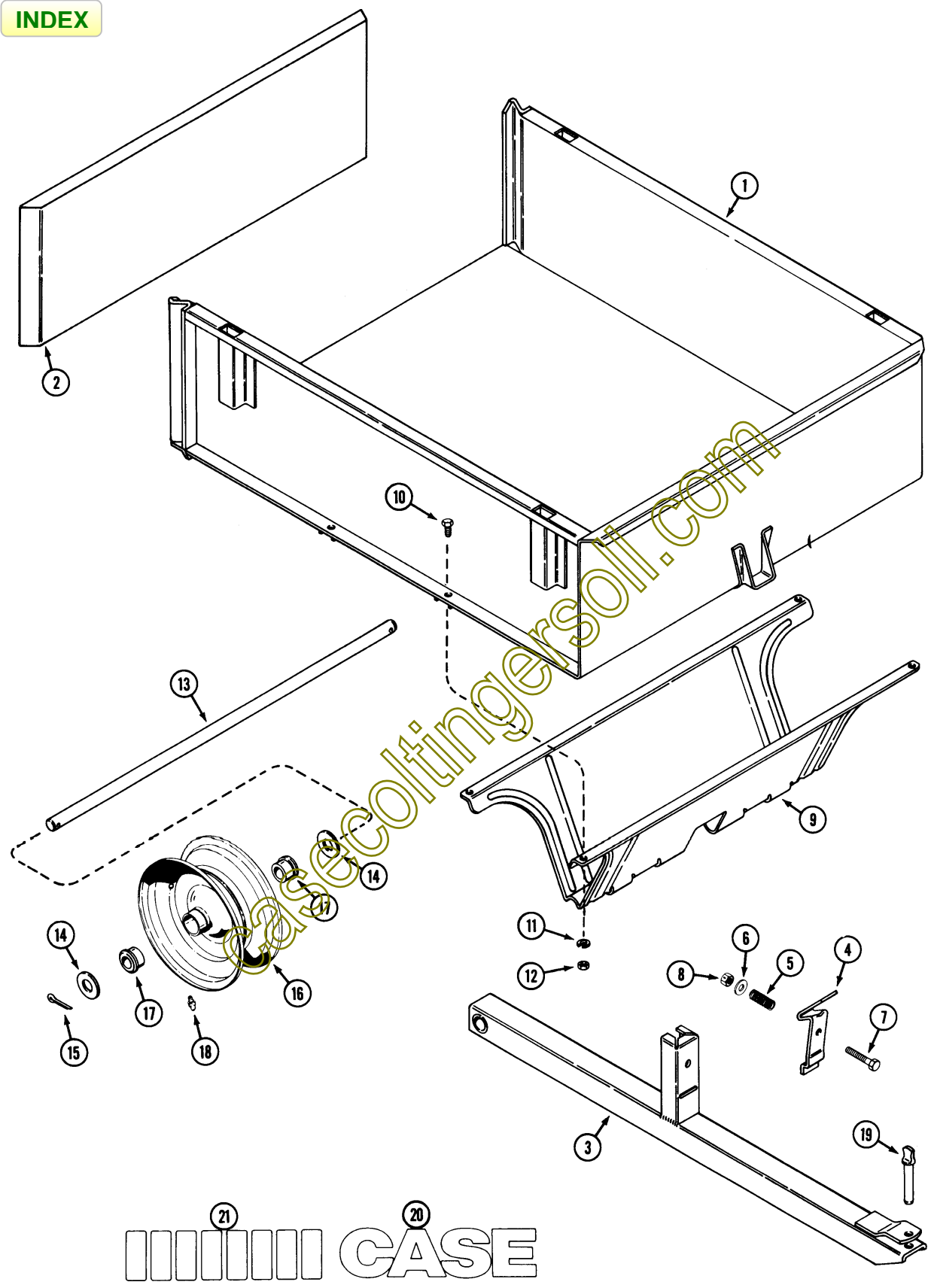

||||| **21** **20** CASE

**INDEX**

**MODEL F60 DUMP CART**

REF.	PART NO.	DESCRIPTION	REQ'D
1	C26464	BODY - cart.....	1
2	C13547	TAILGATE.....	1
3	C26473	TONGUE - hitch.....	1
4	C13859	LEVER - latch.....	1
5	C11942	SPRING - latch.....	1
6	195-2175	WASHER - 11/32".....	1
7	113-111	BOLT - 5/16" - 18 x 2-1/2.....	1
8	131-176	NUT - 5/16" - 18 lock.....	1
9	C26477	SUPPORT - axle.....	1
10	113-102	BOLT - 5/16" - 18 x 3/4".....	4
11	192-20	LOCK WASHER - 5/16".....	4
12	129-102	NUT - 5/16" - 18.....	4
13	C13920	SHAFT - axle.....	1
14	195-553	WASHER - 1.06".....	4
15	132-306	PIN - cotter 3/16" x 1-3/4.....	2
16	C24964	RIM - wheel.....	2
17	C14221	BEARING - flanged.....	4
18	219-1	FITTING - lubrication.....	2
19	C10888	PIN - hitch.....	1
20	321-6379	DECAL - "Case".....	2
21	321-6380	DECAL - tread.....	16

casecoltingersoll.com

INDEX

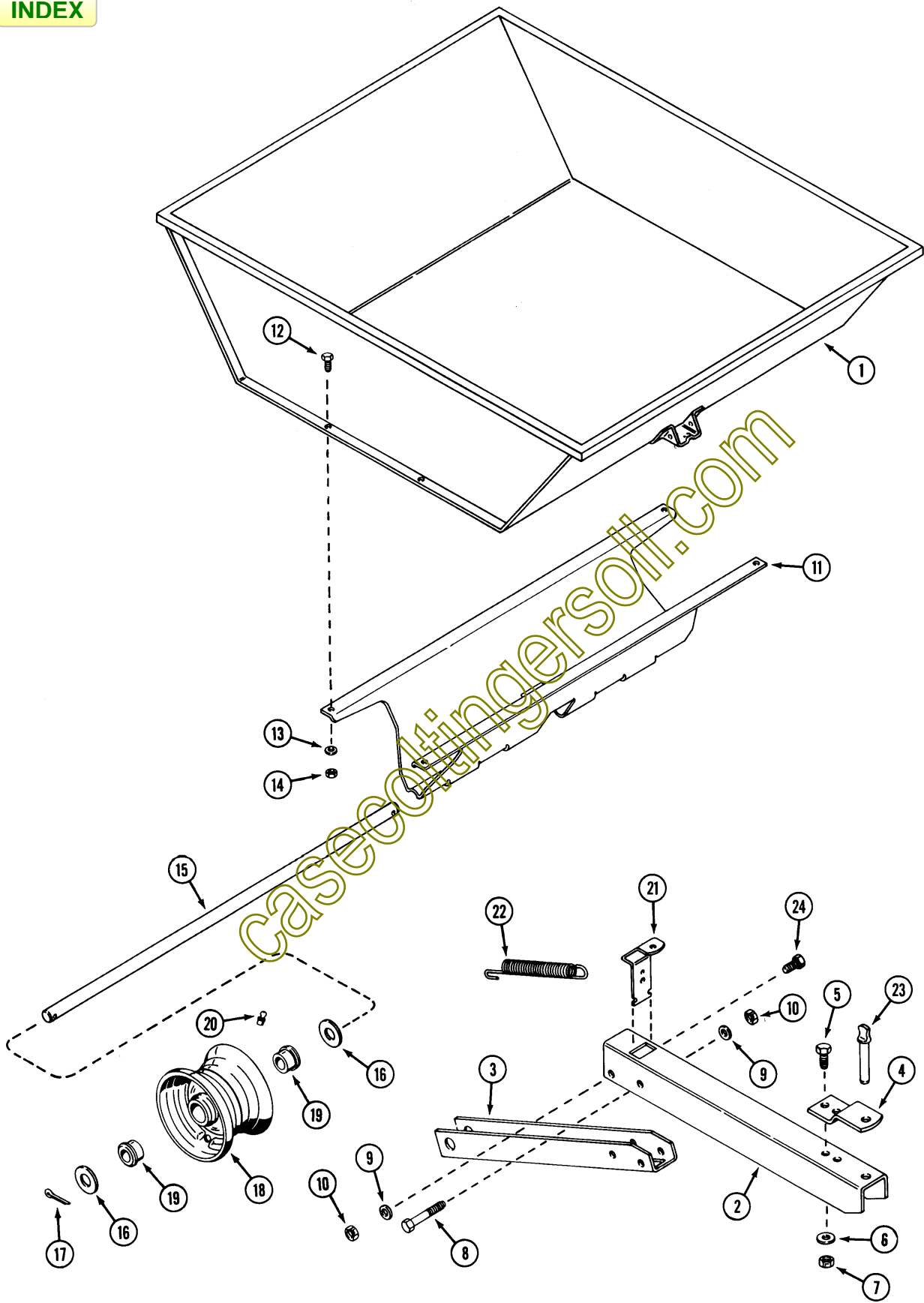



**INDEX**

**MODEL E62 DUMP CART**

REF.	PART NO.	DESCRIPTION	REQ'D
1	C26231	BODY - cart.....	1
2	C26236	TONGUE - front, hitch.....	1
3	C26238	TONGUE - rear, axle.....	1
4	C26237	PLATE - hitch.....	1
5	113-102	BOLT - 5/16" - 18 x 3/4" hex.....	2
6	195-521	WASHER - 5/16".....	2
7	131-176	NUT - 5/16" - 18 lock, hex.....	2
8	113-248	BOLT - 3/8" - 16 x 2-3/4" hex.....	1
9	195-525	WASHER - 3/8".....	3
10	131-1181	NUT - 3/8" - 16 lock, hex.....	3
11	C26239	SUPPORT - axle.....	1
12	113-1	BOLT - 1/4" - 20 x 1/2 hex.....	4
13	195-518	WASHER - 1/4".....	4
14	131-1180	NUT - 1/4" - 20 lock, hex.....	4
15	C26240	SHAFT - axle.....	1
16	195-545	WASHER - 3/4".....	4
17	132-311	PIN - cotter, 5/32" x 1-1/4".....	2
18	C24502	RIM - wheel.....	2
19	C24503	BEARING - flanged.....	4
20	219-10	FITTING - lubrication 1/4".....	2
21	C26241	LEVER - latch.....	1
22	C19553	SPRING - latch.....	1
23	C10888	PIN - hitch.....	1
24	113-206	BOLT - 3/8"-16 x 3/4".....	2
	321-6379	DECAL - "Case".....	2
	321-6380	DECAL - tread.....	8

casecoltingersoil.com

INDEX

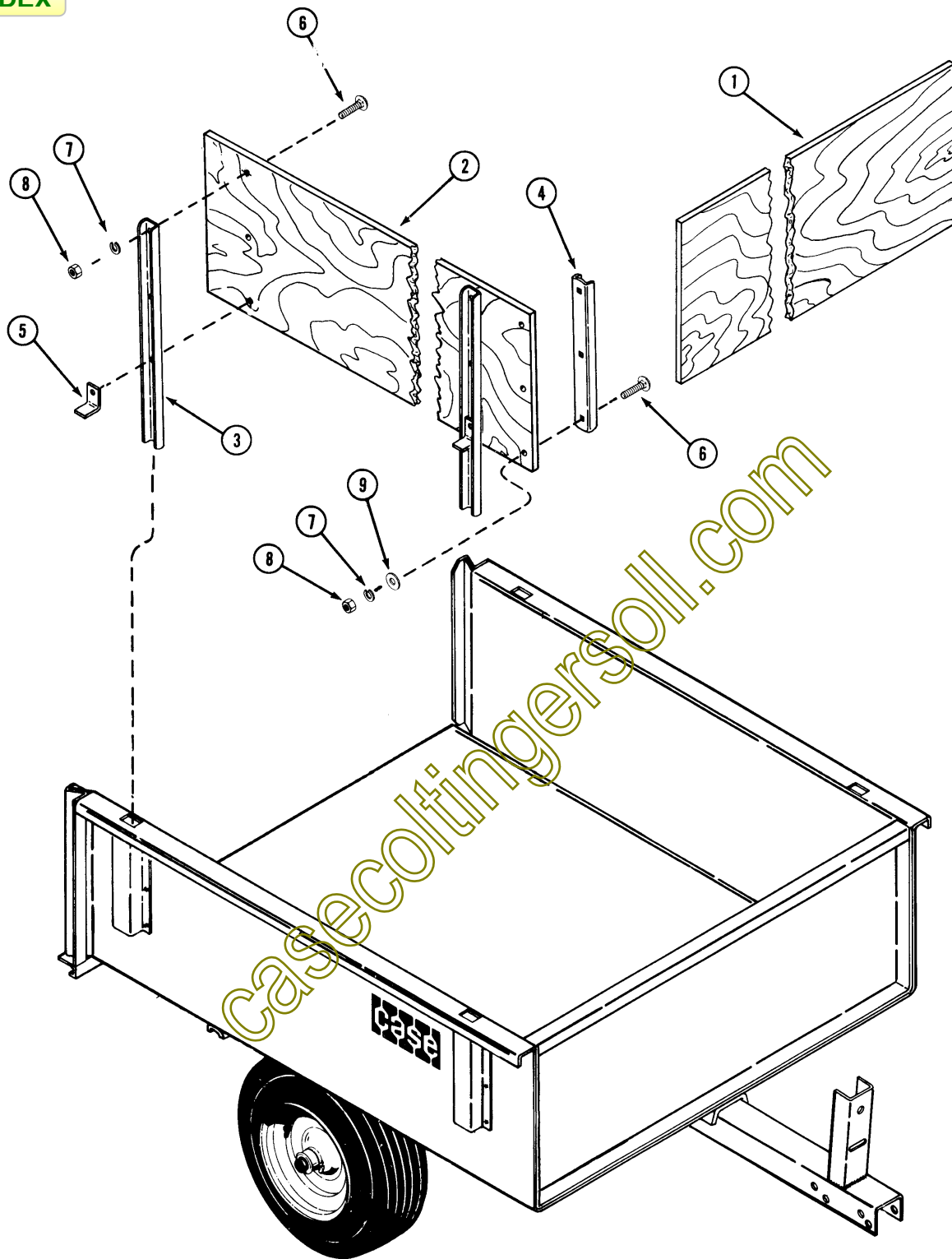

**INDEX**

**MODEL E65 DUMP CART EXTENSIONS**

REF.	PART NO.	DESCRIPTION	REQ'D
1	C17276	BOARD - front .....	1
2	C17277	BOARD - side.....	2
3	C17279	BRACKET – support side.....	4
4	C17280	BRACKET - support froht.....	2
5	C17278	BRACKET - stop .....	4
6	111-111	BOLT - 1/4" x 1" NC rd. hd. square neck .....	18
7	192-19	LOCKWASHER - 1/4" .....	18
8	129-101	NUT - 1/4" NC hex .....	18
9	195-518	WASHER - 1/4" .....	6

casecoltingersoll.com

INDEX

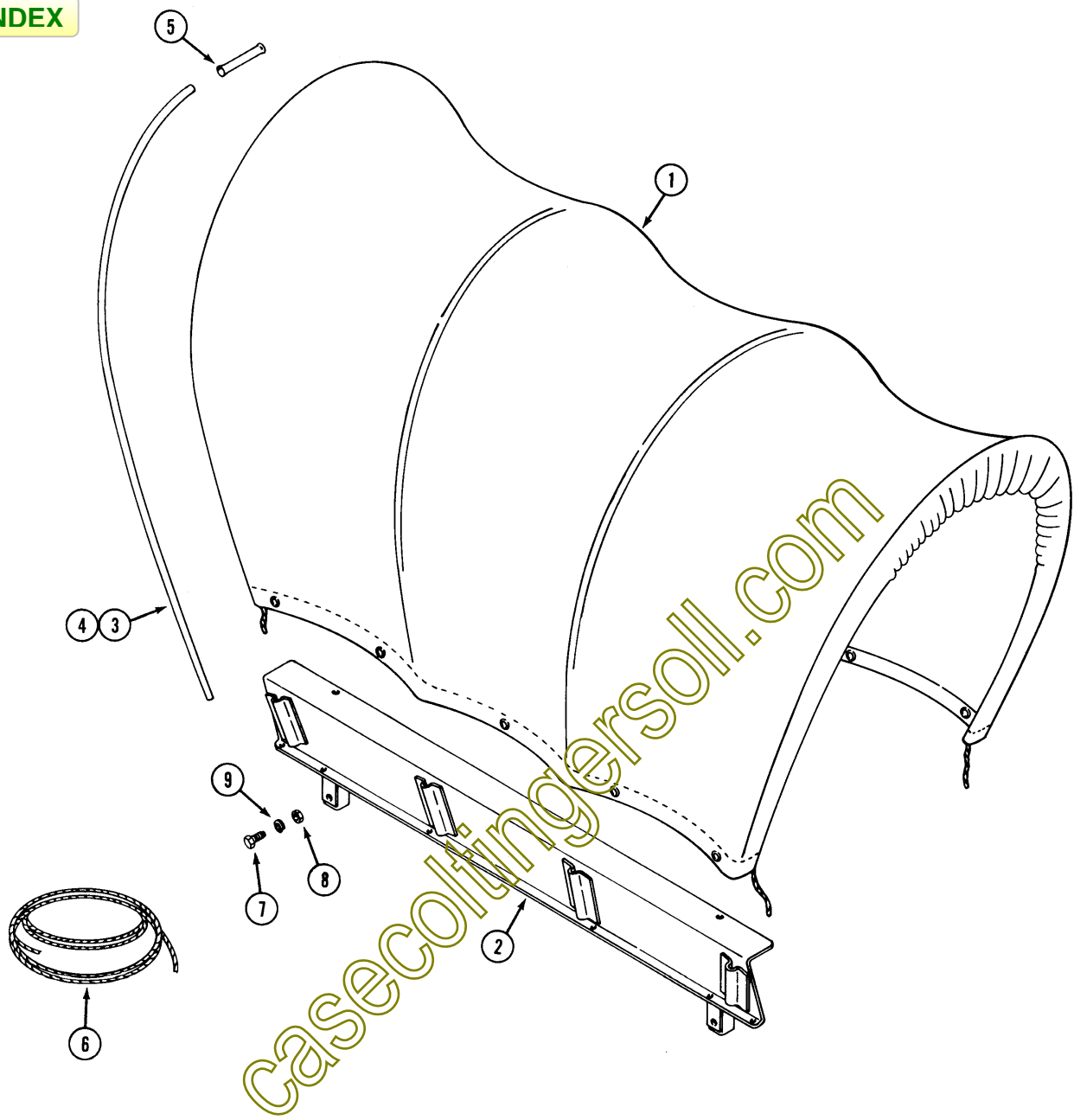

**INDEX**

**F66 CONESTOGA COVER**

REF.	PART NO.	DESCRIPTION	REQ'D
1	C27289	COVER - canvas (includes draw string) .....	1
	NSS	DRAW STRING - 1/4" x 116" (6.4 mm x 3 m) purchase locally .....	2
2	C27290	PLATE - mounting.....	2
3	C27295	ROD - support, end 53" (1.35m) .....	4
4	C27296	ROD - support, center 50" (1.27m) .....	4
5	C27437	CONNECTOR - rod.....	4
6	NSS	ROPE - lashing 1/4" x 48" (6.4 mm x 1.22 m) purchase locally.....	2
7	113-1	BOLT - 1/4" - 20 x 1/2" .....	4
8	129-101	NUT - 1/4" - 20 .....	4
9	192-19	LOCKWASHER - 1/4" .....	4

casecoltingersoll.com