

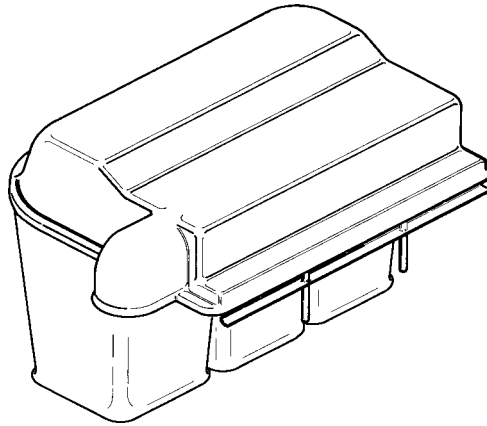

**Ingersoll**

**HOME**

**ATTACHMENTS**



**HYDRAULIC VACUUM  
HVFB, HVFC, AHVFC, AHVFB  
PARTS CATALOG 8-3082**

**ALPHABETICAL INDEX**

Bags .....	13
Boot .....	9
Cover, Bags .....	13
Cover, Cart .....	11
Decals .....	19
Ducts .....	9
Housing, Blower .....	9
Hydraulic System ..... HVFB, HFVC .....	5
Hydraulic System ..... AHVFB, AHVFC .....	7
Impellor .....	5
Impellor .....	7
Motor, Hydraulic .....	15
Motor, Hydraulic .....	17
Mounting Brackets.....	5
Side Panels, Cart .....	11
Support, Bags.....	13

**APPLICATION CHART**

<b>TRACTOR</b>	<b>BLOWER</b>	<b>MOWER</b>
3014, 3016, 3018	HVFB, HVFC	* RM38, RM44, RM48
4014, 4016, 4018, 4020	HVFB, HVFC	RM44, RM48
3118, 4116 4118, 4120	AHVFB, AHVFC	AHRM48

\* Will require narrow rear tires

Dump carts E, F, G60 or DC1000 can be used (Not with bagger)  
See Whole goods Listing for proper PTO valve kit.

casecoltingersoll.com

**INDEX**

There is an index at the front of this catalog. The front index is an alphabetical index of the major groups or assemblies.

**ILLUSTRATION**

Each illustration in this catalog shows a group of parts or components. These parts and components are aligned approximately as the parts and components on your machine. Each part and component in an illustration has a reference number. These reference numbers are in a list on the page opposite of the illustration. Next to the reference number is the part number, description and required quantity of the part shown in the illustration.

UAR - "Use as required" indicates that the part quantity is variable.

NSS - "Not sold separately" indicates that the part is only available as component of an assembly or the part must be purchased locally. If the part is an assembly component, the description will be indented under the assembly description in the parts list.

O/L - "Obtain locally"

- "Footnotes" are added to a part number when more information is needed for identification. They only relate to the part numbers indicated. All orders must include the following information:

1. Correct part number.

**PARTS ORDERS**

2. Complete description of part or component.
3. Total quantity of each part or component.
4. Product model number.
5. All necessary product identification numbers.
6. Method for sending the parts.
7. Complete and correct address.

**CATALOG REVISIONS**

As the product changes, new pages will be available for your catalog. A notice will be issued.

**IMPORTANT:** Put all revisions into the catalog as soon as possible.

**RIGHT HAND AND LEFT HAND IDENTIFICATION**

The words right hand (RH) and left hand (LH) as used in this catalog indicate the direction while you are in the operator's seat in the normal operating position.

**INDENTED DESCRIPTIONS**

An assembly can have many components. The components of an assembly are indicated by an indented description. The quantity for an indented part is the total needed for that complete assembly. See the example.

REF.	PART NO.	DESCRIPTION	REQ'D
	C 55159	CYLINDER ASSY - rear steering .....	1
28	C 56208	SOCKET ASSY - rear cylinder .....	1
29	C 55956	PLUG - adjusting, socket assy .....	1
30	C 55957	SEAT- socket, ball.....	2
31	C 56210	SPRING-socket .....	1
32	C 56209	SEAT - socket spring .....	1
33	G 45175	CLAMP ASSY - socket assy .....	1
	16- 836	BOLT-1/2"x2-1/4" N.F. hex.....	1
34	132- 104	PIN-cotter, 3/16"x3".....	1
35	C 55889	STUD - ball, socket & cylinder .....	2
36	13- 410	BOLT-1/4"x5/8"N.C.,hex .....	4
37	92- 4	LOCK WASHER - 1/4"SAE .....	4

**INDEX**

**PAINT AND OIL**

**PAINT**

REF.	PART NO.	DESCRIPTION	REQ'D
1	C 28849	BLACK - semi - gloss, 12 oz spray (2 per carton) .....	1
2	C 28850	BLACK - semi - gloss, quart (2 per carton) .....	1
3	C 28850	BLACK - semi - gloss, heat resistant, 12 oz spray (2 per carton) .....	1
4	C 28484	POWER RED - gloss, 12 oz spray (2 per carton) .....	1
5	C 28485	POWER RED - gloss, quart (2 per carton) .....	1
6	C 30870	SILVER - gloss, 12 oz. spray (2 per carton) .....	1
7	C 31643	POWER RED - gloss, 1 oz touch up, (1 doz. per carton) .....	1

**OIL**

1	C 32776	OIL - SAE 30, SF, quart (12 per case) .....	1
2	C 32777	OIL - SAE 5W20, SF, quart (12 per case) .....	1
3	C 32778	OIL - SAE 20W40, SF, quart (12 per case) .....	1

casecoltingersoll.com

INDEX

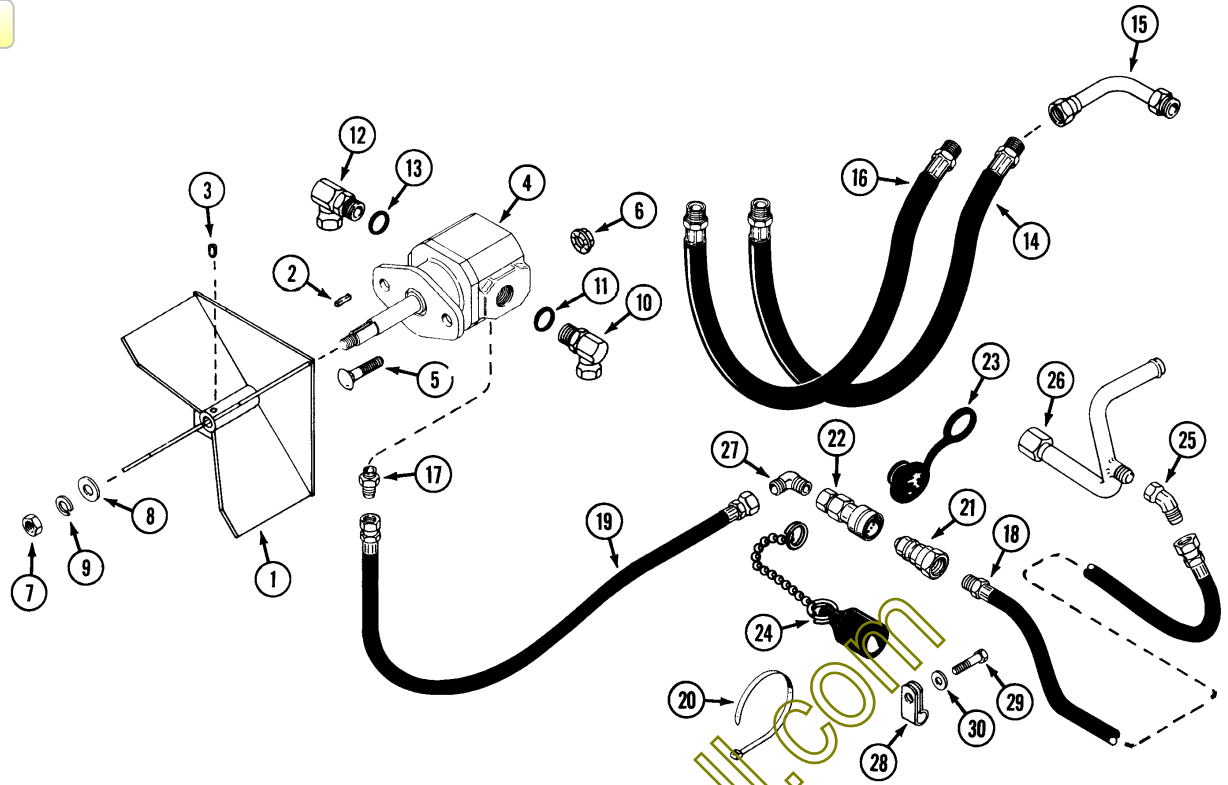

INDEX

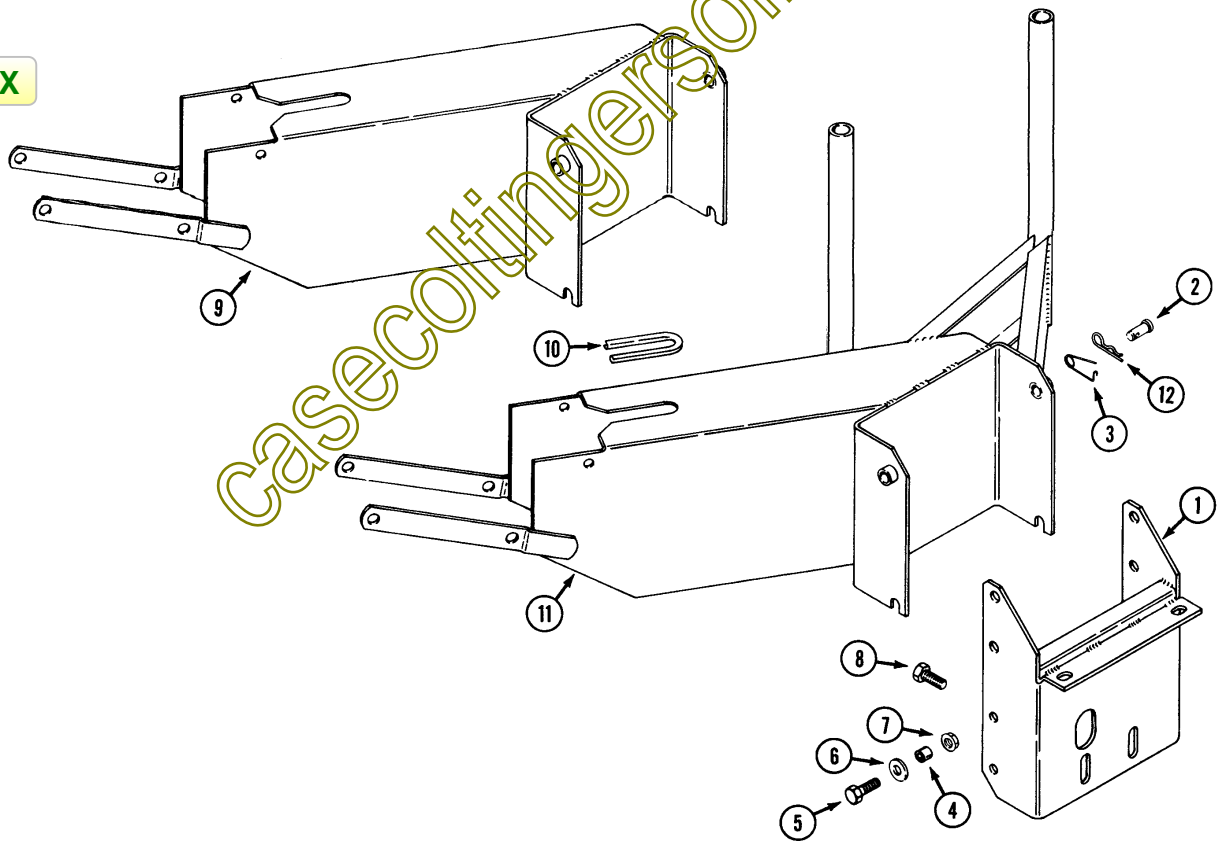

## AHVFC, AHVFB, HVFC AND HVFB HYDRAULIC VACUUMS

## IMPELLOR AND HYDRAULIC MOTOR (HVFC, HVFB)

REF.	PART NO.	DESCRIPTION	REQ'D
1	C28392	IMPELLOR - blower .....	1
2	C28215	KEY - 3/16" square x 5/8" impeller .....	1
3	83-46	SET SCREW - 1/4" - 20 .....	2
4	NSS*	MOTOR - hydraulic (use C33126 kit) (repairs page 15) .....	1
4	C33108**	MOTOR - hydraulic (repairs page 15) .....	1
5	111-371	BOLT - 3/8" - 16 x 1-1/4" carriage .....	2
6	131-938	NUT - 3/8" - 16 flange lock .....	2
7	129-163	NUT - 3/8" - 24 (torque to 20-25 ft. lb.) .....	1
8	195-525	WASHER - 3/8" .....	1
9	192-21	LOCKWASHER - 3/8" .....	1
10	218-5203	FITTING - 90° swivel 3/4" - 16 "O" ring x 1/2" pipe (inlet) .....	1
11	218-5006	"O" RING - fitting .....	1
12	218-5201	FITTING - 90° swivel 7/8" - 14 "O" ring x 1/2" pipe (outlet) .....	1
13	218-5007	"O" RING - fitting .....	1
14	C28320	HOSE - hydraulic 42" .....	1
15	C29882	TUBE - extension .....	2
16	C32347	HOSE - hydraulic 44" .....	1
	C33126	KIT - hydraulic motor with case drain .....	1
17	218-5053	FITTING - 7/16" -20 x 7/16" -20, 370 flare .....	1
18	C33113	HOSE - return manifold to coupling .....	1
18	C33864	HOSE - return manifold to travel valve .....	1
19	C33114	HOSE - motor to coupling .....	1
20	C22947	TIE - nylon .....	3
21	C27713	COUPLING - male .....	1
22	C27714	COUPLING - female .....	1
23	NSS	PLUG - dust (use C33404) .....	1
24	NSS	CAP - dust (use C33404) .....	1
25	218-5172	FITTING - 45° 9/16" - 18 x 9/16" - 18 .....	1
26	C33115	TUBE - travel valve to heat exchanger .....	1
27	218-483	FITTING - 90° 9/16" flare x 1/4" - 18 NPTF .....	1
28	C33125	CLAMP - hose .....	1
29	113-132	BOLT - 1/4" - 20 x 1-3/4" .....	1
30	195-518	WASHER - 1/4" .....	1

\* Use before S/N:

\*\* Use S/N and after:

HVFB - 016077

HVFC - 016510

## ADAPTER AND MOUNTING BRACKET

1	C29916	BRACKET - tractor adapter .....	1
2	141-56	PIN - clevis 1/2" x 1-3/8" .....	2
3	C10898	PIN - safety (HVFC, AHVFC) .....	2
4	C14768	SPACER .....	2
5	113-208	BOLT - 3/8" - 16 x 1-1/4" .....	2
6	195-525	WASHER-3/8" .....	2
7	131-938	NUT - 3/8" - 16 flange .....	2
8	113-417	BOLT-1/2"-13 x 1-1/4" .....	2
9	C32335	BRACKET - mounting (HVFC, AHVFC) .....	2
10	C33274	TRIM - strip .....	UAR
11	C32349	BRACKET - mounting (HVFB, AHVFB) .....	1
12	C29029	PIN - cotter hair pin (HVFB, AHVFB) .....	2

INDEX

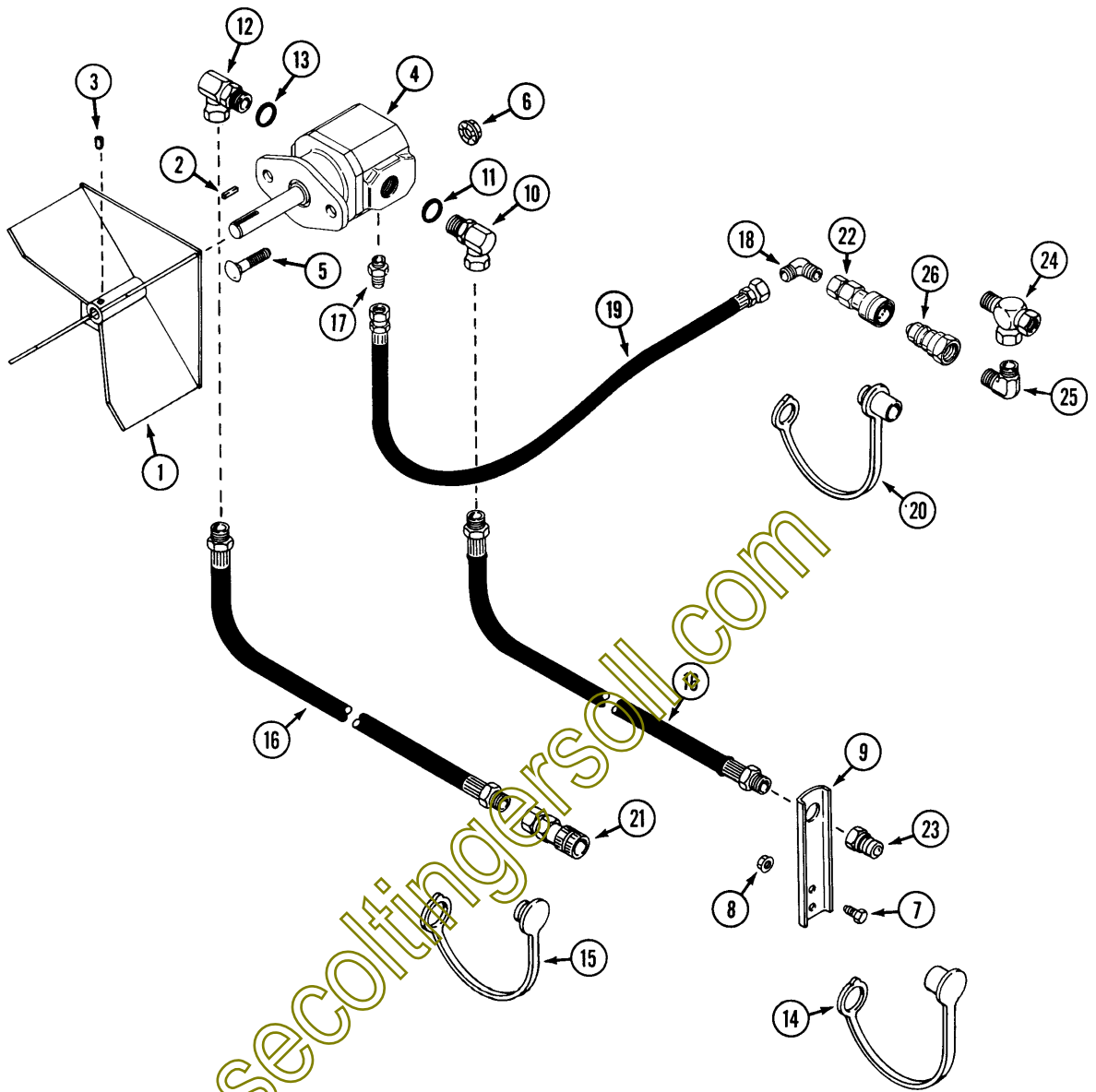

casecollectors.com

**AHVFC. AHVFB. HVFC AND HVFB HYDRAULIC VACUUMS**

**IMPELLOR AND HYDRAULIC MOTOR (AHVFC, AHVFB)**

REF.	PART NO.	DESCRIPTION	REQ'D
1	C42102	IMPELLOR - blower .....	1
2	C43446	KEY - 3/16" square x 1-1/4" .....	1
3	61-46	SCREW - 1/4" - 20 x 3/8" .....	3
4	C42099	MOTOR - hydraulic (repairs page 17) .....	1
5	111-371	BOLT - 3/8" - 16 x 1-1/4" carriage .....	2
6	131-938	NUT - 3/8" - 16 flange lock .....	2
7	113-118	BOLT - 5/16" - 18 x 5/8" .....	2
8	131-911	NUT - 5/16" - 18 flange lock .....	2
9	C42139	BRACKET - anchor .....	1
10	218-5203	FITTING - 90° swivel 3/4" - 16 "0" ring x 1/2" pipe (inlet) .....	1
11	218-5007	"0" RING .....	1
12	218-5201	FITTING - 90° swivel 7/8" - 14 "0" ring x 1/2" pipe (outlet) .....	1
13	218-5007	"0" RING .....	1
14	C40641	CAP - dust .....	1
15	C40642	PLUG - dust .....	1
16	C42138	HOSE - hydraulic 44" .....	2
17	218-5053	FITTING - 7/16" - 20 x 7/16" - 20, 37° flare .....	1
18	218-483	FITTING - 90° elbow .....	1
19	C33114	HOSE - case drain, motor to coupling 50" .....	1
20	C33404	CAP/PLUG - dust .....	2
21	C37188	COUPLING - female .....	1
22	C41044	COUPLING - female, case drain .....	1
23	C37187	COUPLING - male .....	2
24	217-1062	FITTING - tee .....	1
25	217-1225	FITTING - 90° elbow .....	1
26	C41043	COUPLING - male, case drain .....	1

casecoltingersoil.com

INDEX

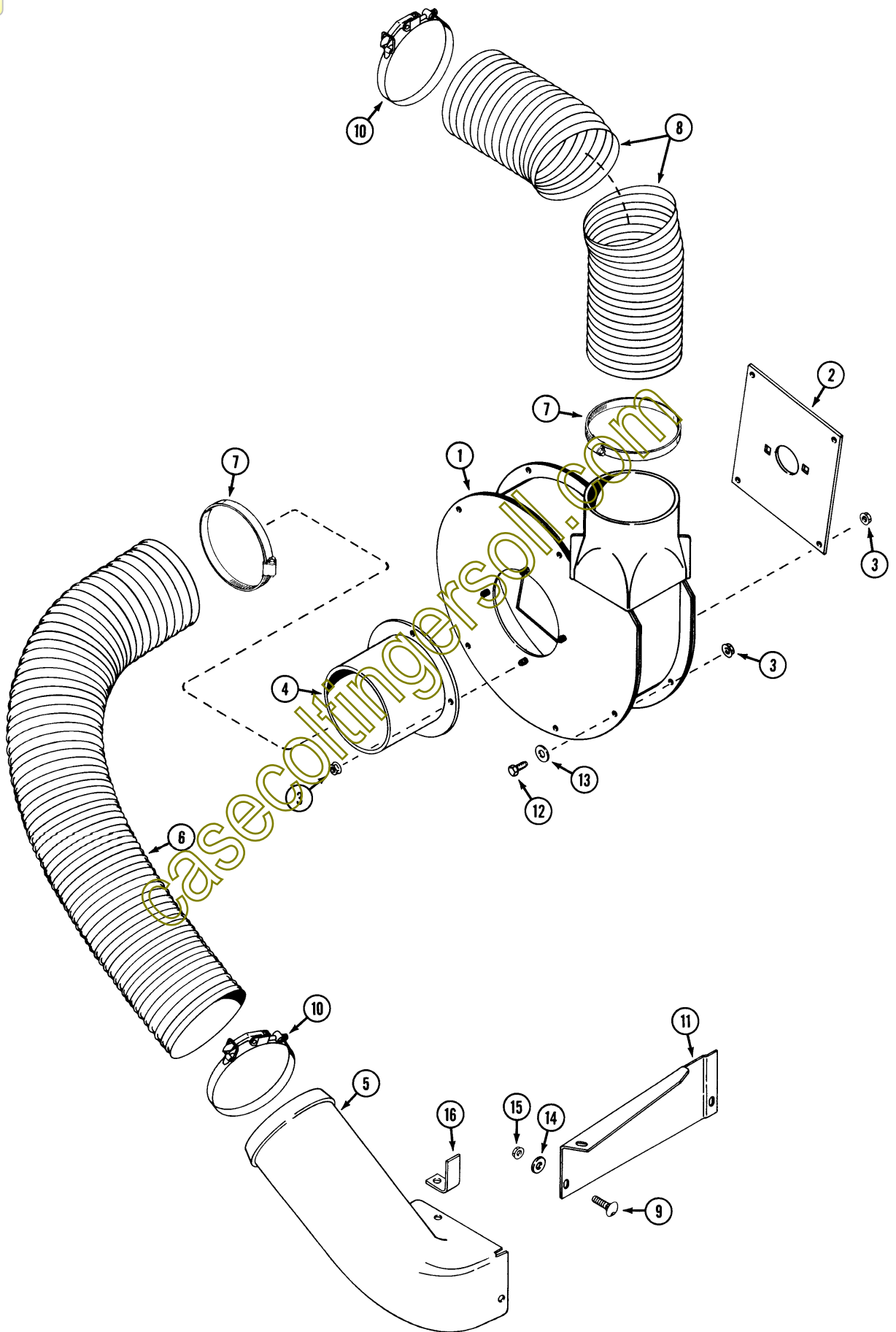



**AHVFC, AHVFB, HVFC AND HVFB HYDRAULIC VACUUMS**

**BLOWER HOUSING, DUCTS AND TUBES**

REF.	PART NO.	DESCRIPTION	REQ'D
1	C32334	HOUSING - blower.....	1
2	C28396	PLATE - motor mounting.....	1
3	131-911	NUT - 5/16" - 18 flange lock.....	16
4	C29890	DUCT - blower inlet.....	1
5	C32341	BOOT - mower.....	1
6	C30266	TUBE - blower intake 45" to 48".....	1
7	214-277	CLAMP - chute, worm drive.....	UAR
8	NSS	TUBE - blower discharge (use C30266).....	1
9	111-132	BOLT - 5/16" - 18 x 3/4" carriage.....	4
10	C28413	CLAMP - chute (Shown).....	UAR
10	C46359	CLAMP - chute, with adjusting knob.....	UAR
11	C32342	BAFFLE - mower.....	1
12	113-103	BOLT - 5/16" - 18 x 1.....	6
13	195-2175	WASHER - .344"x 1.25".....	4
14	195-521	WASHER - 5/16".....	1
15	131-911	NUT - 5/16" - 18.....	4
16	C32994	SUPPORT - discharge chute.....	1

casecoltingersoll.com

INDEX

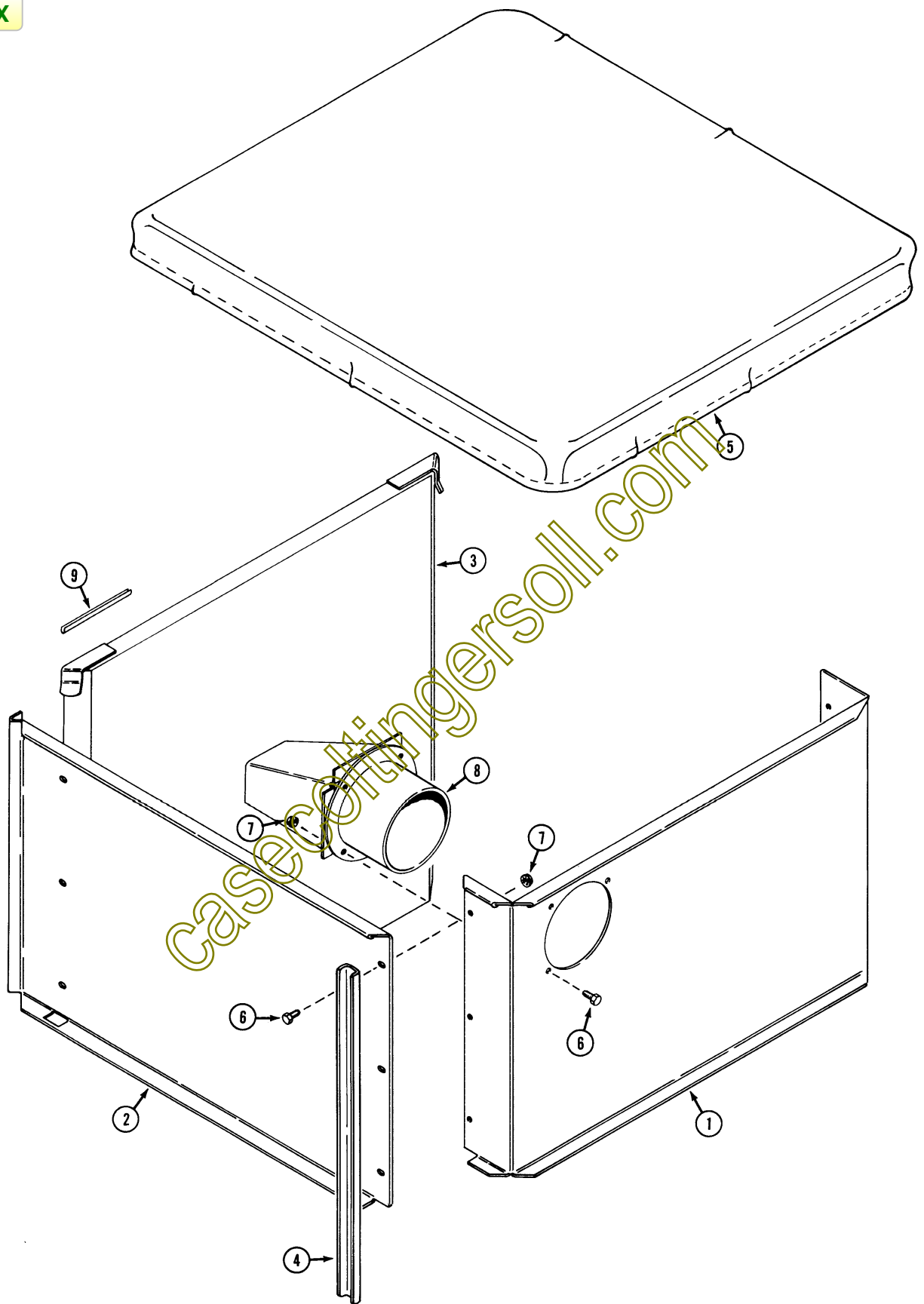

**AHVFC, AHVFB, HVFC AND HVFB HYDRAULIC VACUUMS**

**CART ENCLOSURE (HVFC. AHVFC)**

REF.	PART NO.	DESCRIPTION	REQ'D
1	C32345	PANEL - front .....	1
2	C28418	PANEL - side L.H .....	1
2	C28419	PANEL - side R.H. (shown).....	1
3	C32414	TAILGATE .....	1
4	C28420	CHANNEL - support.....	4
5	C30102	COVER - cart .....	1
6	113-102	BOLT - 5/16" - 18 x 3/4" .....	15
7	131-911	NUT - 5/16" - 18 flange lock.....	15
8	C28414	DEFLECTOR - debris .....	1
9	C33274	TRIM - strip.....	UAR

casecoltingersoll.com

INDEX

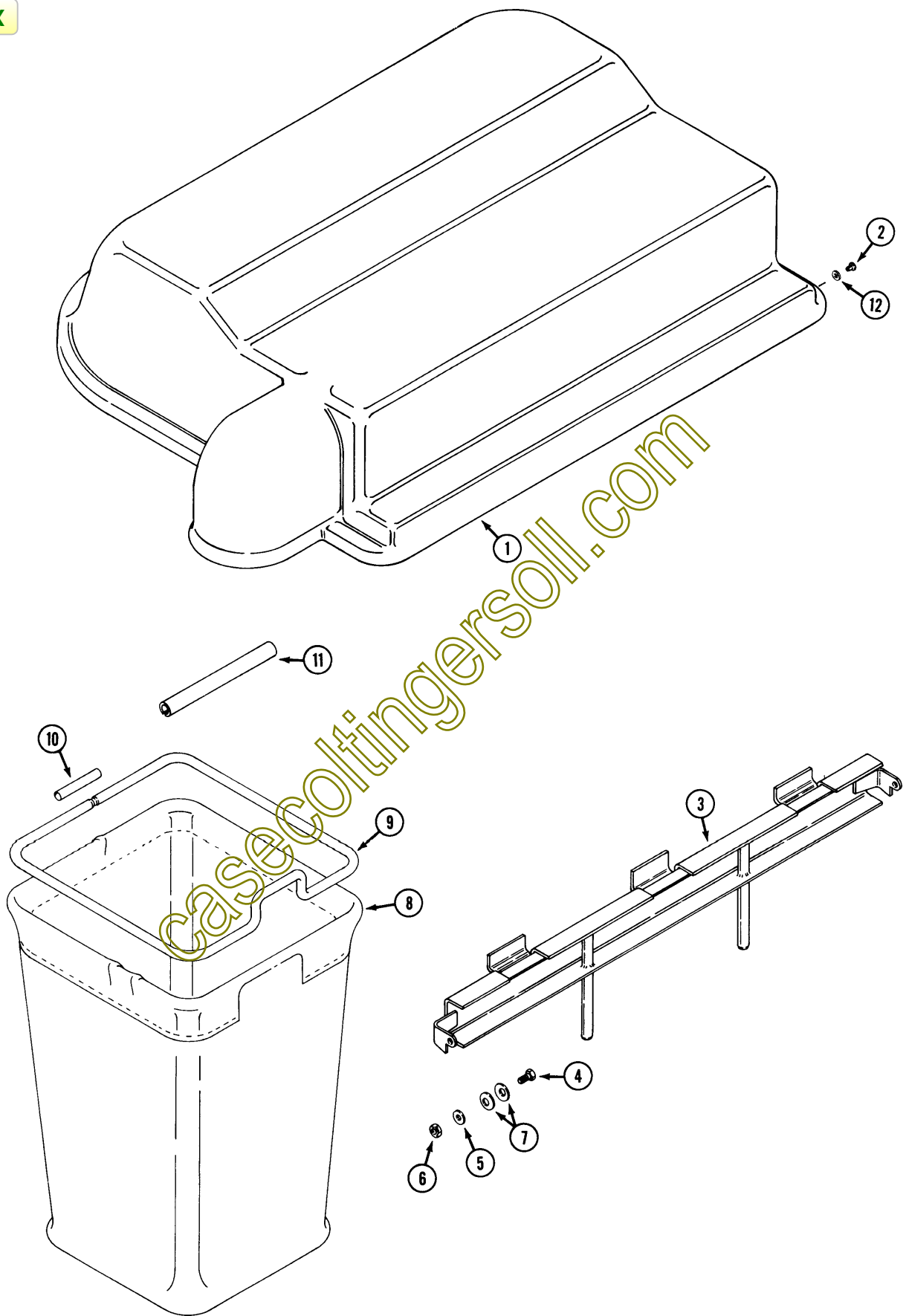

**INDEX**

**AHVFC, AHVFB, HVFC AND HVFB HYDRAULIC VACUUMS**

**BAGS, COVER AND SUPPORT FRAME (HVFB, AHVFB)**

REF.	PART NO.	DESCRIPTION	REQ'D
1	C32351	COVER - bagger .....	1
2	151-539	RIVET - pop.....	UAR
3	C32357	FRAME - support .....	1
4	113-103	BOLT - 5/16" - 18 x 1" .....	2
5	195-521	WASHER - 5/16" .....	2
6	131-176	NUT - 5/16" - 18 lock.....	2
7	C25114	SPRING WASHER - Belleville .....	4
8	C28438	BAG.....	3
9	C29897	ROD - bag reinforcement.....	3
10	C28440	TUBE - connector.....	3
11	C32400	GUARD - bag .....	3
12	195-513	WASHER - 7/32" x 1/2" .....	4

casecoltingersoll.com

**INDEX**

### HYDRAULIC MOTOR (HVFB, HVFC)

Use Before S/N:

HVFB - 016077

HVFC - 016510

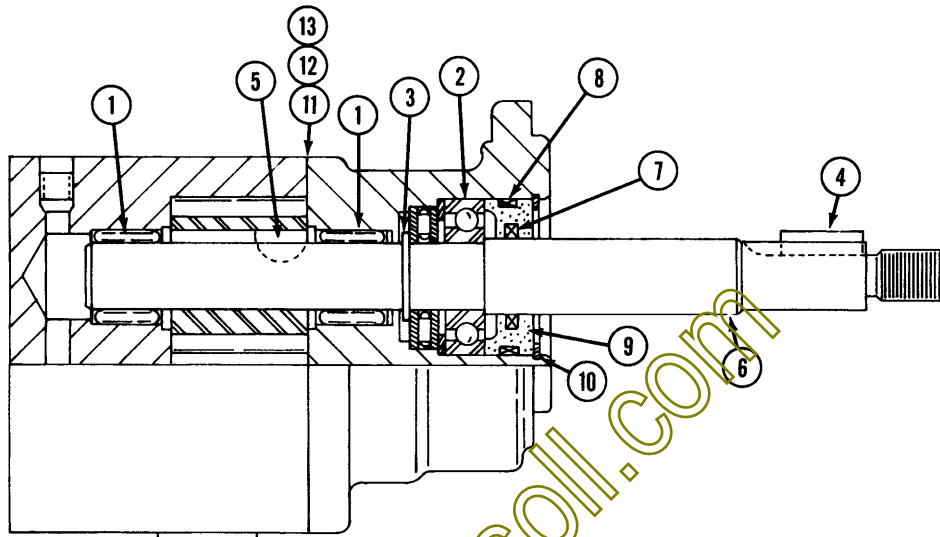

**INDEX**

### HYDRAULIC MOTOR (HVFB, HVFC)

Use S/N and after:

HVFB - 016077

HVFB - 016510

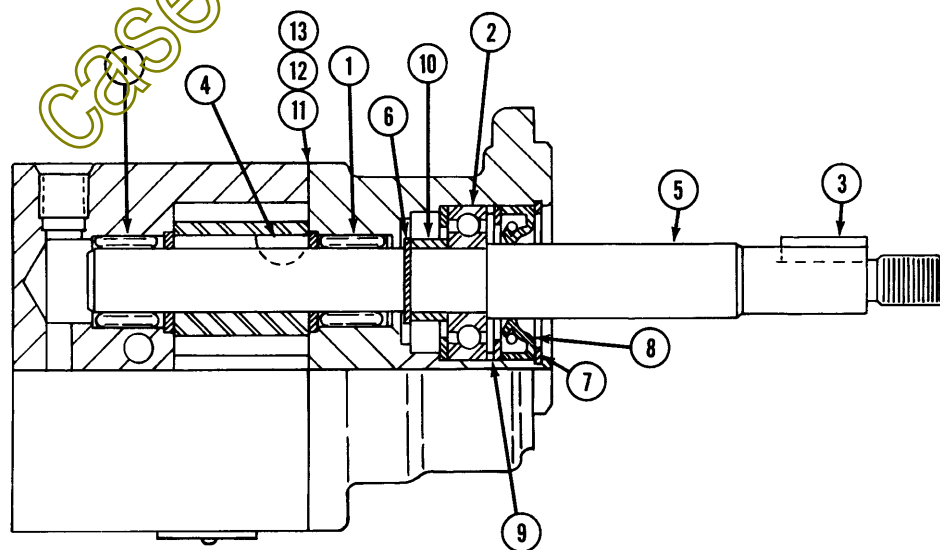

**AHVFC, AHVFB, HVFC AND HVFB HYDRAULIC VACUUMS**

**HYDRAULIC MOTOR (HVFB, HVFC)**

**Use Before S/N:  
HVFB - 016077  
HVFC - 016510**

REF.	PART NO.	DESCRIPTION	REQ'D
	NSS	MOTOR - hydraulic (use C33126 kit).....	1
1	C33292	BEARING - needle.....	4
2	C33293	BEARING - ball.....	1
	C33303	KIT - shaft repair.....	1
3	NSS	RING - snap 1/2" external.....	1
4	C28215	KEY - square 3/16".....	1
5	126-6	KEY - woodruff 1/8" x 3/8".....	1
6	NSS	SHAFT - hydraulic motor.....	1
	C33304	KIT - seal.....	1
7	NSS	"O" RING - internal.....	1
8	NSS	"O" RING - external.....	1
9	NSS	RETAINER - seal.....	1
10	NSS	RING - snap 1-1/8" internal.....	1
11	NSS	GASKET - body .00050" (silver).....	UAR
12	NSS	GASKET - body .00075" (gold).....	UAR
13	NSS	GASKET - body .00100" (amber).....	UAR

**HYDRAULIC MOTOR (HVFB, HVFC)**

**Use S/N and after:  
HVFB - 016077  
HVFC - 016510**

	C33108	MOTOR - hydraulic.....	1
1	C33292	BEARING - needle.....	4
2	C33293	BEARING - ball.....	1
	C33301	KIT - shaft repair.....	1
3	C28215	KEY - square 3/16".....	1
4	126-6	KEY - woodruff 1/8" x 3/8".....	1
5	NSS	SHAFT - hydraulic motor.....	1
6	NSS	RING - snap 1/2" external.....	1
	C33302	KIT - seal.....	1
7	NSS	RING - snap 1-1/8" internal.....	1
8	C33282	SEAL - oil.....	1
9	NSS	SPACER - seal.....	1
10	NSS	SPACER - bearing.....	1
11	NSS	GASKET - body .00050" (silver).....	UAR
12	NSS	GASKET - body .00075" (gold).....	UAR
13	NSS	GASKET - body .00100" (amber).....	UAR

**INDEX**

**HYDRAULIC MOTOR (AHVFB, AHVFC)**

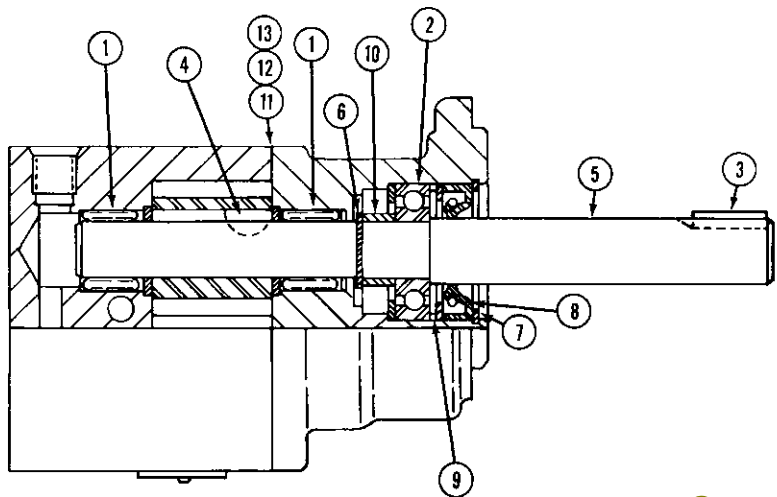

REF.	PART NO.	DESCRIPTION	REQ'D
	C42099	MOTOR - hydraulic .....	1
1	C33292	BEARING - needle.....	4
2	C33293	BEARING - ball.....	1
	C43593	KIT - shaft repair .....	1
3	C43446	KEY - square 3/16" x 1-1/4".....	1
4	126-6	KEY - woodruff 1/8" x 3/8".....	1
5	NSS	SHAFT - hydraulic motor.....	1
6	NSS	RING - snap 1/2" external.....	1
	C33302	KIT - seal .....	1
7	NSS	RING - snap 1-1/8" internal.....	1
8	C43673	SEAL-oil.....	1
9	NSS	SPACER - seal.....	1
10	NSS	SPACER - bearing.....	1
11	NSS	GASKET - body .00050" (silver).....	UAR
12	NSS	GASKET - body .00075" (gold).....	UAR
13	NSS	GASKET - body .00100" (amber).....	UAR

casecoincingersonoil.com



④  
**INGERSOLL**

**⚠ WARNING**

**FLYING DEBRIS**  
**OPERATE MOWER ONLY**  
**WITH DISCHARGE CHUTE**  
**GUARD/COVER OR COMPLETE**  
**GRASS CATCHER IN PLACE.**  
**DEBRIS MAY CAUSE INJURY**

**⚠ CAUTION**

**FLYING DEBRIS**

1. DO NOT RAISE COVER WHILE OPERATING.  
 2. PROPERLY INSTALL BAGGER AND CHUTE  
 BEFORE STARTING MOWER. SEE OPER-  
 ATORS MANUAL FOR FURTHER  
 INSTRUCTIONS.

①  
**⚠ DANGER**

**SPINNING BLADE**  
 SEE OPERATOR'S MANUAL BEFORE  
 ATTEMPTING TO CLEAR PLUGGED  
 DISCHARGE CHUTE.  
 CONTACT WITH BLADE CAN RESULT IN  
 SERIOUS INJURY.

REF.	PART NO.	DESCRIPTION	REQ'D
1	C31089	DECAL - "Spinning Blade" .....	UAR
2	C31086	DECAL - "Flying Debris".....	1
3	C31088	DECAL - "Flying Debris".....	1
4	C31989	DECAL - "Ingersoll" shown.....	1

casecoltingersoll.com