

STRAP STEEL CUTTING DIAGRAM

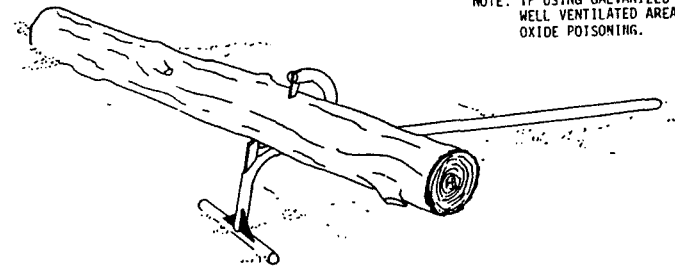
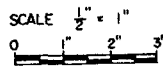

PERSPECTIVE

NO SCALE

NOTE: IF USING GALVANIZED PIPE, WELD IN WELL VENTILATED AREA TO AVOID ZINC OXIDE POISONING.

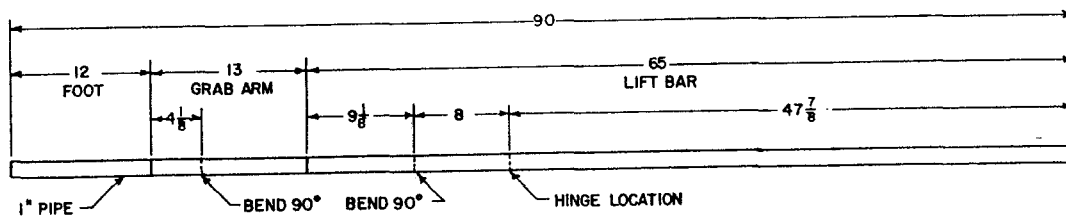

BLACK IRON PIPE CUTTING DIAGRAM

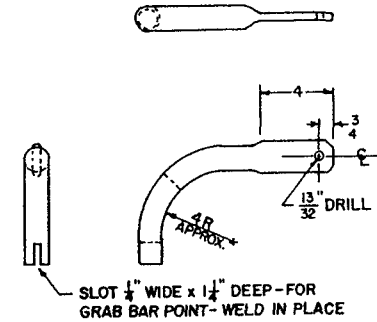
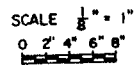

GRAB BAR DETAILS

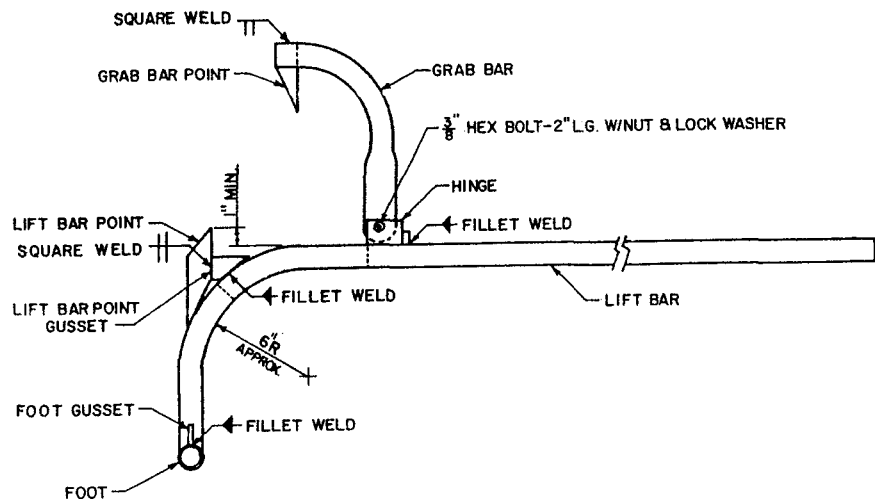
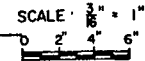

ASSEMBLY DRAWINGS

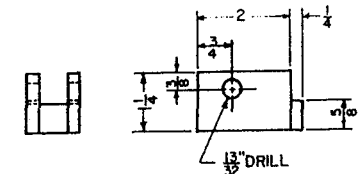
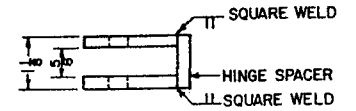
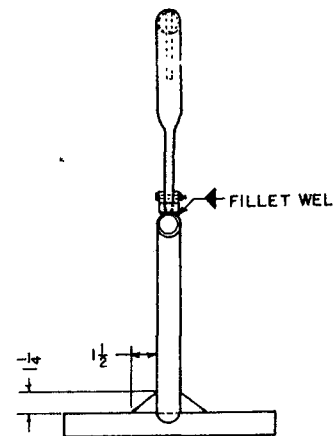
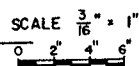

HINGE DETAILS

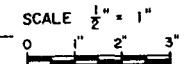

12" LOG LIFTER

W VA'86 6379 SHEET 1 OF 1

Disclaimer

This site makes available conceptual plans that can be helpful in developing building layouts and selecting equipment for various agricultural applications. These plans do not necessarily represent the most current technology or construction codes. They are not construction plans and do not replace the need for competent design assistance in developing safe, legal and well-functioning agricultural building system. The LSU Agriculture Center, the Mid-West Plan Service, the United States Department of Agriculture and none of the cooperating land-grant universities warranty these plans.