

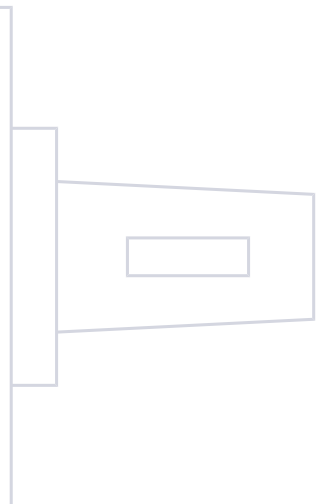

cascolindersoll.com

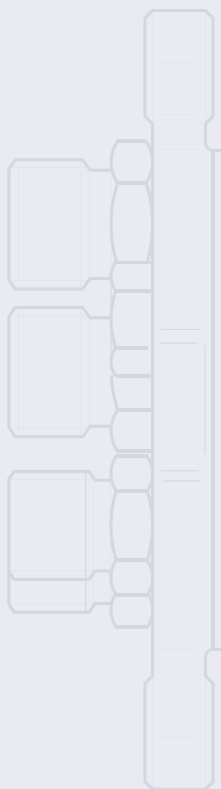

**A WIDE RANGE OF STEERING COMPONENTS**

F300599

Sauer-Danfoss is the largest producer in the world of steering components for hydrostatic steering systems on off-road vehicles. Sauer-Danfoss offer steering solutions both at component and system levels. Our product range makes it possible to cover applications of all types - ranging from ordinary 2-wheel steering (also known as Ackermann steering) to articulated steering, complicated 4-wheel steering, automatic steering (e.g. by sensor) and remote controlled steering via satellite. We can offer more than 1000 different steering units, 150 different priority valves and 300 different steering columns categorised in types, variants and sizes.

**For hydrostatic steering systems Sauer-Danfoss offers:**

- Mini steering units with displacements from 32 to 100 cm<sup>3</sup>/rev [1.95 to 6.10 in<sup>3</sup>/rev], flow up to 20 l/min [5.28 US gal/min], steering pressure up to 125 bar [1813 psi]
- Steering units with displacements from 40 to 1000 cm<sup>3</sup>/rev [2.44 to 61.0 in<sup>3</sup>/rev], flow up to 100 l/min [26.4 US gal/min], steering pressure up to 210 bar [3045 psi]
- Priority valves for rated flows at 40, 80, 120 and 160 l/min [10.6, 21.1, 31.7 and 42.3 US gal/min], pressure up to 350 bar [5076 psi]
- Pilot operated flow-amplifiers with amplification factors of 4, 5, 8, 10 or 20 for rated oil flows of 240 and 400 l/min [63.4 and 105.7 US gal/min], steering pressure up to 210 bar [3045 psi]
- Pilot operated steering valve with steering flow up to 100 l/min [26.4 US gal/min], steering pressure up to 250 bar [3625 psi] and with integrated priority valve for pump flow up to 150 l/min [39.6 US gal/min].

© 2001 Sauer-Danfoss

Sauer-Danfoss can accept no responsibility for possible errors in catalogues, brochures and other printed material. Sauer-Danfoss reserves the right to alter its products without prior notice. This also applies to products already ordered provided that such alterations can be made without subsequent changes being necessary in specifications already agreed. All trademarks in this material are properties of the respective companies. Sauer-Danfoss and the Sauer-Danfoss logotype are trademarks of the Sauer-Danfoss Group. All rights reserved.

Frontpage: P300015.TIF, P300016.TIF, P300017.TIF, P300019.TIF, Pic00016, P300018.TIF, Drawing 151-536.ai

**A WIDE RANGE OF STEERING COMPONENTS  
 (CONTINUED)**

**For electro-hydraulic steering systems Sauer-Danfoss offers:**

- Pilot operated steering valve (pilot operated by hydrostatic steering unit or by electrical signal) with steering flow up to 100 l/min [26.4 US gal/min], steering pressure up to 250 bar [3625 psi] and with integrated priority valve for pump flow up to 150 l/min [39.6 US gal/min]

**For hydromechanical steering systems Sauer-Danfoss offers:**

- Torque amplifiers for output torques of 80 and 120 Nm [708 and 1062 lbf-in]

**For steering units and torque amplifiers Sauer-Danfoss offers:**

- Steering columns: fixed, tiltable and/or telescopic with or without horn switch and sensor for start/stop of pump, with length, from 45 to 1200 mm [1.77 to 47.2 in]

**Characteristic features of steering units:**

- Low steering torque: From 0.5 Nm to 3 Nm [4.42 to 26.6 lbf-in] in normal steering situations
- Low noise level
- Low pressure drop
- Many types available: Open center Non reaction, Open center Reaction, Closed center Non reaction, Load Sensing, Load Sensing Reaction, Power Beyond
- One or more built-in valve functions: relief valve, shock and suction valves in L- and R-line, none return valve in P-line and in LS-line
- Optional port connections (according to ISO, SAE or DIN standards)

**Characteristic features of electro-hydraulic steering system:**

- High steering pressure requiring smaller cylinders and flow
- Low noise emission in the cab because of low pilot pressure
- The possibility of emergency steering even on very heavy vehicles
- Minimization of side acceleration with articulated steering
- With microcontroller: No steering wheel drift and the possibility of variable steering ratio
- Analogue and CAN-bus interface
- Electro-hydraulic steering valve EHPS can be combined with Sauer-Danfoss PVG 32 proportional valve
- The system is approved by TÜV and have a controller with safety critical steering software

**CONVERSION FACTORS**

1 Nm = 8.851 lbf-in  
 1 N = 0.225 lbf  
 1 bar = 14.50 psi  
 1 mm = 0.0394 in

1 cm<sup>3</sup> = 0.061 in<sup>3</sup>  
 1 litre = 0.264 US gal  
 °F = 1.8 × °C + 32

**CONTENTS AND TECHNICAL LITERATURE SURVEY**

**A wide range of steering components** ..... 2

    Conversion factors..... 3

**Survey of literature with technical data on sauer-danfoss steering componenets** ..... 5

**Application**..... 6

    Advantages ..... 6

    Function ..... 6

**Steering units OSPM** ..... 7

    Versions ..... 7

    Code numbers and weights..... 8

        OSPM ON..... 8

        OSPM PB ..... 9

    Specification table none catalogue for numbers of Sauer Danfoss OSPM steering units ..... 10

    Technical data ..... 11

        Displacement, flow and pressure ..... 11

        Manual steering pressure..... 12

        Valve functions in OSPM steering units ..... 12

        Pressure drop in neutral..... 13

    Port connections..... 13

    Dimensions OSPM ..... 14

**Steering columns for OSPM** ..... 15

    Technical data ..... 15

        Load on integrated steering column ..... 15

        Load on separate steering column ..... 15

    Installing the steering column ..... 16

    Splined tube section for steering columns ..... 16

    Versions ..... 17

    Code numbers and weights..... 17

    Dimensions ..... 18

        OTPM ..... 18

        OTPM-T ..... 19

**SURVEY OF LITTERATURE  
 WITH TECHNICAL DATA  
 ON SAUER-DANFOSS  
 STEERING COMPO-  
 NENETS**

Detailed data on all Sauer-Danfoss steering components and accessories can be found in our steering component catalogues, which is divided in 6 individual subcatalogues:

- General information Steering components  
DKMH.PK.200.A1.02 **520L0468**
- Technical data on mini steering units and steering columns for mini steering units: OSPM and OTPM  
DKMH.PN.210.PD.02 **520L0438**
- Technical data on open center and closed center steering units and on torque amplifiers: OSPB, OSPC, OSPR, OSPD and TAD  
DKMH.PK.210.A1.02 **520L0502**
- Technical data on load sensing steering units, priority valves and flow-amplifiers: OSPB, OSPC, OSPF, OSPD, OSPQ,  
OSPPL, OSPBX, OSPCX, OSPLX, OLS  
and OSQ  
DKMH.PN.210.B1.02 **520L0520**
- Technical data on hydraulic and electro-hydraulic pilot operated steering valve, appropriate steering units and electrical actuation module as well as sensors for electro-hydraulic steering systems EHPS and OSPCX  
PVE and PVED for EHPS and sen-  
sors for steering systems with  
EHPS  
DKMH.PN.270.B1.02 **520L0521**
- Technical data on valve blocks and steering columns OVP, OVPL, OVR and OTPB  
DKMH.PN.230.A1.02 **520L0522**

The most important data on all Sauer-Danfoss steering components is highlighted in a general survey brochure.  
 For technical information on individual variants, please contact the Sauer-Danfoss Sales Organisation

casecoatingerson.com

## APPLICATION

Sauer-Danfoss has marketed mini-steering unit OSPM and the matching steering column OTPM ever since 1995. Positive feedback from the market has now motivated the implementation of the following upratings in the program of OSPM mini-steering units:

- Max pressure loads increased. Now up to a 125 bar [1813 psi] steering pressure
- Additional variants introduced. E.g. new 40, 63 and 100 cm<sup>3</sup> [2.44 in<sup>3</sup>, 3.84 and 6.10 in<sup>3</sup>] displacements plus supplementary valve functions.
- Introduction of tilt able steering column OTPM-T for OSPM
- Production capacity considerably expanded through establishment of a European parallel to the original US-production. Steering units from the two factories are provided with their own separate code numbers. OSPM-customers on the American continent will be provided with mini-steering units from the OSPM-factory in the USA, whilst OSPM for all other customers will be delivered from the steering unit factory in Europe.

### Examples:

- Minitractors
- Mowing machines
- Universal tractors
- Forklift trucks
- Municipal vehicles

## ADVANTAGES

- Small dimensions and low weight
- End ports with integrated fittings
- Easy installation
- Possibility of integrated steering column
- Low pressure drop
- Low input torque
- Low system price

## FUNCTION

OSPM is a hydrostatic steering unit which can be used with an add-on steering column, OTPM/OTPM-T or with the steering column integrated with the unit.

The steering unit consists of a rotary valve and a rotary meter.

Via a steering column or directly the steering unit is connected to the steering wheel of the vehicle. When the steering wheel is turned, oil is directed from the steering system pump via the rotary valve and rotary meter to the cylinder ports L or R, depending on the direction of turn. The rotary meter meters the oil flow to the steering cylinder in proportion to the angular rotation of the steering wheel.

If the oil supply from the steering system pump fails or is too small, the steering unit is able to work as a manual steering pump.

**VERSIONS**

The mini-steering unit is available in two versions:

- Open-Center Non-Reaction (ON) version, and
- Power Beyond (PB) version where surplus oil can be led to the working hydraulics.

*OSPM-ON*

Open centre steering units have open connection between pump and tank in the neutral position.

*OSPM-PB*

In Power Beyond steering units the oil from the pump is routed in the neutral position through the steering unit to the E-port.

The steering function always has priority, with any excess oil flow passing through the E port.

If the steering wheel is held at full lock, all flow is led to tank across the pressure relief valve, and flow from the E port will stop.

casecontrol.com

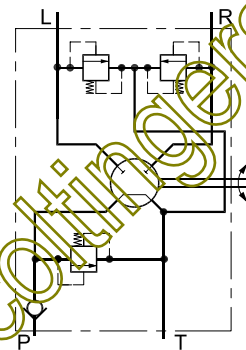

150-539.11

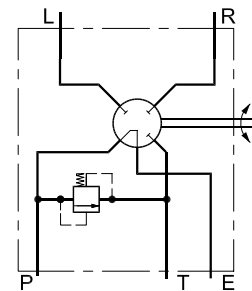

150-540.11

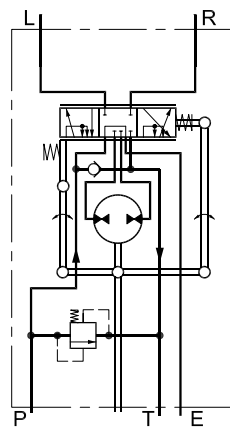
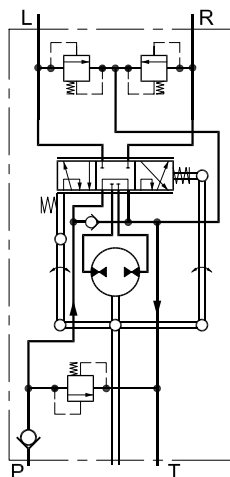

**CODE NUMBERS AND WEIGHTS**

The mini-steering unit is available with displacements of 32, 40, 50, 63, 80 and 100 cm<sup>3</sup>/rev. [1.95, 2.44, 3.05, 3.84, 4.88 and 6.10 in<sup>3</sup>/rev.] The check valve for emergency steering is standard in all versions, but optionally, the OSPM can also be fitted with an integrated relief valve and/or a shock valve and a check valve in the P-port.

The OSPM is also available with an integrated steering column or alternatively in a version prepared for a flange-on steering column (see page 17). The connections are integrated end-port fittings of the ORFS-type (O-ring face seal). See page 13.

**OSPM  
 OPEN CENTER NON-  
 REACTION STEERING  
 UNITS**

Steering unit	Code No. OSPM from USA	Code No. OSPM from Europe	Relief valve bar [psi]	Shock valves bar [psi]	Check valve in P-port	Steering wheel connection	Weight kg [lb]
OSPM 32 ON	150L0101		None	None	None	Flanged-on	2.3 [5.1]
OSPM 32 ON	150L0102	150L2102	None	None	None	Integrated type A	2.3 [5.1]
OSPM 32 ON	150L0103	150L2103	75-80 [1087-1160]	None	None	Flanged-on	2,3 [5.1]
OSPM 32 ON	150L0104	150L2104	75-80 [1087-1160]	None	None	Integrated type A	2.3 [5.1]
OSPM 40 ON	-	150L2079	75-80 [1087-1160]	None	None	Flanged-on	2.4 [5.3]
OSPM 50 ON	150L0111		None	None	None	Flanged-on	2.5 [5.5]
OSPM 50 ON	150L0112		None	None	None	Integrated type A	2.5 [5.5]
OSPM 50 ON	150L0133		None	None	None	Integrated type B	2.5 [5.5]
OSPM 50 ON	150L0113	150L2113	75-80 [1087-1160]	None	None	Flanged-on	2.5 [5.5]
OSPM 50 ON	150L0114	150L2114	75-80 [1087-1160]	None	None	Integrated type A	2.5 [5.5]
OSPM 50 ON	150L0150	150L2150	90-95 [1305-1378]	150-170 [2175-2465]	Yes	Integrated type A	2.5 [5.5]
OSPM 50 ON	150L0132	150L2132	75-80 [1087-1160]	None	None	Integrated type B	2.5 [5.5]
OSPM 63 ON	150L0142		75-80 [1087-1160]	None	None	Flanged-on	2.6 [5.7]
OSPM 63 ON	150L0143		75-80 [1087-1160]	None	None	Integrated type A	2.6 [5.7]
OSPM 63 ON	150L0144		75-80 [1087-1160]	None	None	Integrated type B	2.6 [5.7]
OSPM 80 ON	150L0121		None	None	None	Flanged-on	2.7 [5.9]
OSPM 80 ON	150L0122		None	None	None	Integrated type A	2.7 [5.9]
OSPM 80 ON	150L0137		None	None	None	Integrated type B	2.7 [5.9]
OSPM 80 ON	150L0123	150L2123	75-80 bar [1087-1160]	None	None	Flanged-on	2.7 [5.9]
OSPM 80 ON	150L0124	150L2124	75-80 bar [1087-1160]	None	None	Integrated type A	2.7 [5.9]
OSPM 80 ON	150L0136	150L2136	75-80 bar [1087-1160]	None	None	Integrated type B	2.7 [5.9]
OSPM 100 ON	150L0154		75-80 [1087-1160]	None	None	Flanged-on	2.9 [6.4]
OSPM 100 ON	150L0155		75-80 [1087-1160]	None	None	Integrated type A	2.9 [6.4]
OSPM 100 ON	150L0156		75-80 bar [1087-1160]	None	None	Integrated type B	2.9 [6.4]



**CODE NUMBERS**

**OSPM  
 POWER BEYOND  
 STEERING UNITS**

Steering unit	Code No. OSPM from USA	Code No. OSPM from Europe	Relief valve bar [psi]	Shock valves bar [psi]	Check valve in P-port	Steering wheel connection	Weight kg [lb]
OSPM 32 PB	150L0105		None	None	None	Flanged-on	2.6 [5.7]
OSPM 32 PB	150L0106	150L2106	None	None	None	Integrated type A	2.6 [5.7]
OSPM 32 PB	150L0107		75-80 [1087-1160]	None	None	Flanged-on	2.6 [5.7]
OSPM 32 PB	150L0108	150L2108	75-80 [1087-1160]	None	None	Integrated type A	2.6 [5.7]
OSPM 50 PB	150L0115		None	None	None	Flanged-on	2.8 [6.2]
OSPM 50 PB	150L0116		None	None	None	Integrated type A	2.8 [6.2]
OSPM 50 PB	150L0135		None	None	None	Integrated type B	2.8 [6.2]
OSPM 50 PB	150L0117	150L2117	75-80 [1087-1160]	None	None	Flanged-on	2.8 [6.2]
OSPM 50 PB	150L0118	150L2118	75-80 [1087-1160]	None	None	Integrated type A	2.8 [6.2]
OSPM 50 PB	150L0134		75-80 [1087-1160]	None	None	Integrated type B	2.8 [6.2]
OSPM 63 PB	150L0163		75-80 bar [1087-1160]	None	None	Flanged-on	2.9 [6.4]
OSPM 63 PB	150L0164		75-80 bar [1087-1160]	None	None	Integrated type A	2.9 [6.4]
OSPM 63 PB	150L0165		75-80 bar [1087-1160]	None	None	Integrated type B	2.9 [6.4]
OSPM 80 PB	150L0125		None	None	None	Flanged-on	3.0 [6.6]
OSPM 80 PB	150L0126		None	None	None	Integrated type A	3.0 [6.6]
OSPM 80 PB	150L0139		None	None	None	Integrated type B	3.0 [6.6]
OSPM 80 PB	150L0127		75-80 bar [1087-1160]	None	None	Flanged-on	3.0 [6.6]
OSPM 80 PB	150L0128	150L2128	75-80 bar [1087-1160]	None	None	Integrated type A	3.0 [6.6]
OSPM 80 PB	150L0138		75-80 bar [1087-1160]	None	None	Integrated type B	3.0 [6.6]
OSPM 100 PB	150L0160		75-80 bar [1087-1160]	None	None	Flanged-on	3.2 [7.1]
OSPM 100 PB	150L0161		75-80 bar [1087-1160]	None	None	Integrated type A	3.2 [7.1]
OSPM 100 PB	150L0162		75-80 bar [1087-1160]	None	None	Integrated type B	3.2 [7.1]

If you wish other valve combinations or valve settings please fill in the order form on page 10 and contact the Sauer-Danfoss Sales Organisation.

**SPECIFICATION TABLE  
 NONE CATALOGUE FOR  
 NUMBERS OF  
 SAUER-DANFOSS OSPM  
 STEERING UNITS**

Fill in your company data and place x's in the table where appropriate, then send to your local Sauer-Danfoss Sales Organization

Your company	Name		Vehicle		Potential, pcs/year		Completed by	Date
Steering unit type	OSPM ON					OSPM PB		
DP*cm <sup>3</sup> /rev [in <sup>3</sup> /rev]	32 [1.95]	40 [2.44]	50 [3.05]	63 [3.84]	80 [4.88]	100 [6.10]		
OSPM								
RV** bar [psi]	75 [1087]	80 [1160]	90 [1305]	100 [1450]	110 [1595]	125 [1812]	no relief valve	
Shock valves bar [psi]	130 [1885]	140 [2030]	150 [2175]	160 [2320]	170 [2610]	185 [2683]	no shock valves	
Check valve in P-line	Yes					No		

DP\* = Displacement  
 RV\*\* = Pilot pressure relief valve

An alternativ way to specify a variant is to state an existing code number and add the modifications, you would like to have in the basic steering unit.  
 Code number of basic steering unit: \_\_\_\_\_  
 Requested modifications: \_\_\_\_\_

\_\_\_\_\_

\_\_\_\_\_

\_\_\_\_\_

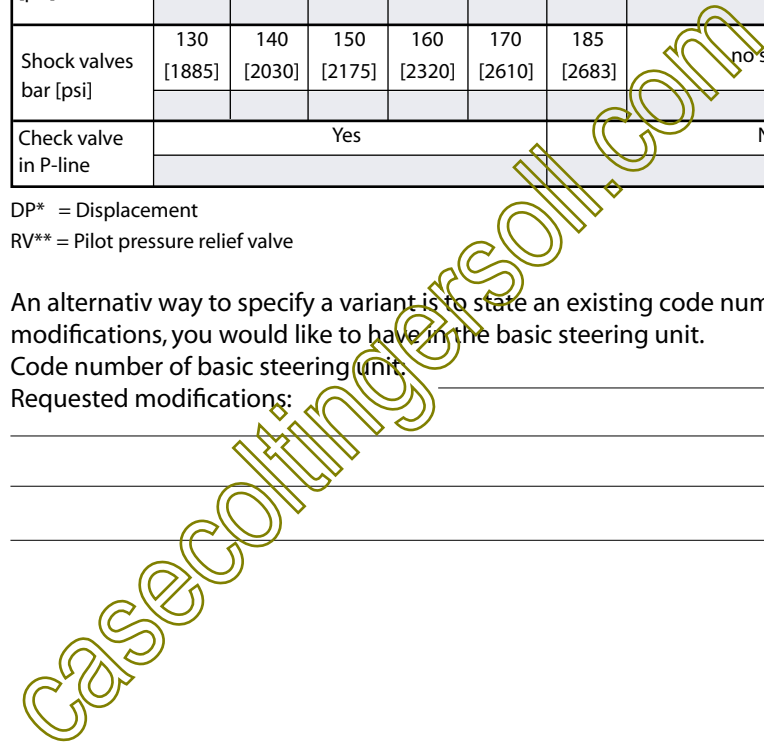

**TECHNICAL DATA**

*Common data:*

Look in sub catalogue: "General Steering Components" page 28

**DISPLACEMENT, FLOW AND PRESSURE**

Steering unit	Displacement cm <sup>3</sup> /rev [in <sup>3</sup> /rev]	Recommended* oil flow l/min [US gal/min]	Max. pressure on connections			
			P bar [psi]	T bar [psi]	L, R bar [psi]	E bar [psi]
OSPM 32 ON	32 [1.95]	3-9 [0.8-2.4]	125 [1813]	20 [290]	180 [2610]	-
OSPM 40 ON	40 [2.44]	4-12 [1.1-3.2]	125 [1813]	20 [290]	180 [2610]	-
OSPM 50 ON	50 [3.05]	5-15 [1.3-4.0]	125 [1813]	20 [290]	180 [2610]	-
OSPM 63 ON	63 [3.84]	6-18 [1.6-4.8]	125 [1813]	20 [290]	180 [2610]	-
OSPM 80 ON	80 [4.88]	7-20 [1.9-5.3]	125 [1813]	20 [290]	180 [2610]	-
OSPM 100 ON	100 [6.10]	7-20 [1.9-5.3]	125 [1813]	20 [290]	180 [2610]	-
OSPM 32 PB	32 [1.95]	3-20 [0.8-5.3]	125 [1813]	20 [290]	180 [2610]	125 [1813]
OSPM 40 PB	40 [2.44]	4-20 [1.1-5.3]	125 [1813]	20 [290]	180 [2610]	125 [1813]
OSPM 50 PB	50 [3.05]	5-20 [1.3-5.3]	125 [1813]	20 [290]	180 [2610]	125 [1813]
OSPM 63 PB	63 [3.84]	6-20 [1.6-5.3]	125 [1813]	20 [290]	180 [2610]	125 [1813]
OSPM 80 PB	80 [4.88]	7-20 [1.9-5.3]	125 [1813]	20 [290]	180 [2610]	125 [1813]
OSPM 100 PB	100 [6.10]	7-20 [1.9-5.3]	125 [1813]	20 [290]	180 [2610]	125 [1813]

\* Criteria for determining the recommended oil flow:

- Must minimum be the oil flow it takes to ensure sufficient steering speed at idle motor speed
- Must ensure the least possible pressure loss at full speed

The steering unit can cope with an oil flow that is up to 50% higher than the maximum recommended value.

**MANUAL STEERING PRESSURE**

Under normal operating where the steering pumps supplies an adequate oil flow at the required pressure, the maximum torque on the steering wheel will not exceed 2 Nm [17.7 lbf-in]. If the oil flow from the steering system pump fails or is too small, the steering unit functions automatically as a manual steering pump. Manual steering can only be used for a limited control of the vehicle if a sudden drop of pump pressure occurs. The table below shows the manual steering pressure ( $P_m$ ) for all sizes of Sauer-Danfoss steering units type OSPM at a steering wheel torque of 80 Nm [708 lbf-in]. The values apply only if the suction conditions on the steering unit T port are adequate.

OSPM		32	40	50	63	80	100
$P_m$	bar	100	90	80	60	50	40
	psi	[1450]	[1305]	[1160]	[870]	[725]	[580]

**VALVE FUNCTIONS IN OSPM STEERING UNITS**

The data below comes from measurements on a representative sample of steering units from production. Oil with a viscosity of 21 mm<sup>2</sup>/s [100 SUS] at 50°C [122°F] was used during measuring.

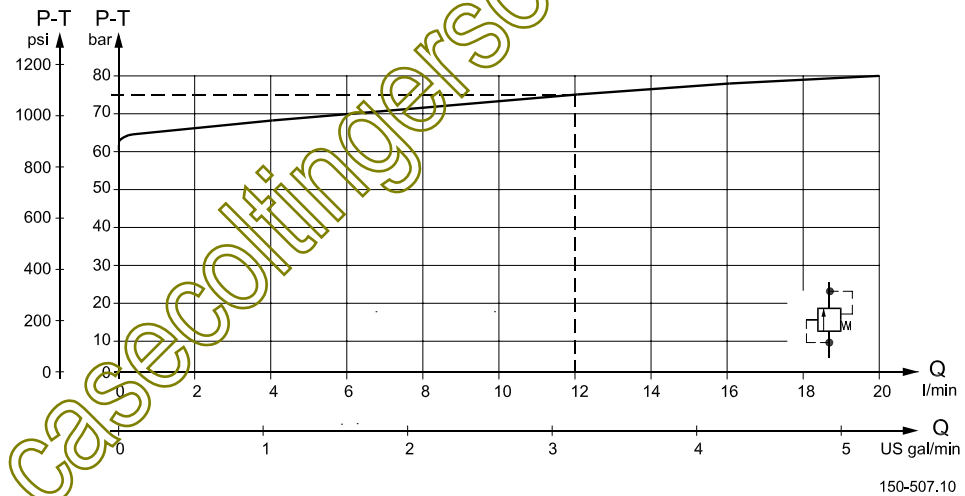

**PRESSURE RELIEF VALVE**

The pressure relief valve protects the pump and steering unit against excess pressure and limits the system pressure while steering. The pressure relief valve in the steering unit will limit the maximum pressure drop from P to T. The pressure relief valve is set at 12 l/min [3.17 US gal/min] flow.

**SHOCK VALVE**

The shock valves protect the steering unit against shocks from external forces on the steering cylinder. The shock valves in the steering unit limit the max pressure drop from L to T and from R to T. The shock valves are set at 1 l/min [0.27 US gal/min]. They are of the direct type and therefore have a very quick reaction. The setting tolerance is +20 bar [+290 psi].

**CHECK VALVES**

The check valve protects the driver against kickbacks in the steering wheel. It prevents the oil from flowing back into the pump line during steering under high pressure on the cylinder side. The check valve is mounted in the P-connection of the steering unit.

**PRESSURE DROP IN NEUTRAL**

The pressure drop is measured with the steering unit in neutral position.  
 On the OSPM ON the pressure drop is measured from P to T.  
 On the OSPM PB the pressure drop is measured from P to E.  
 The values are valid at an oil temperature

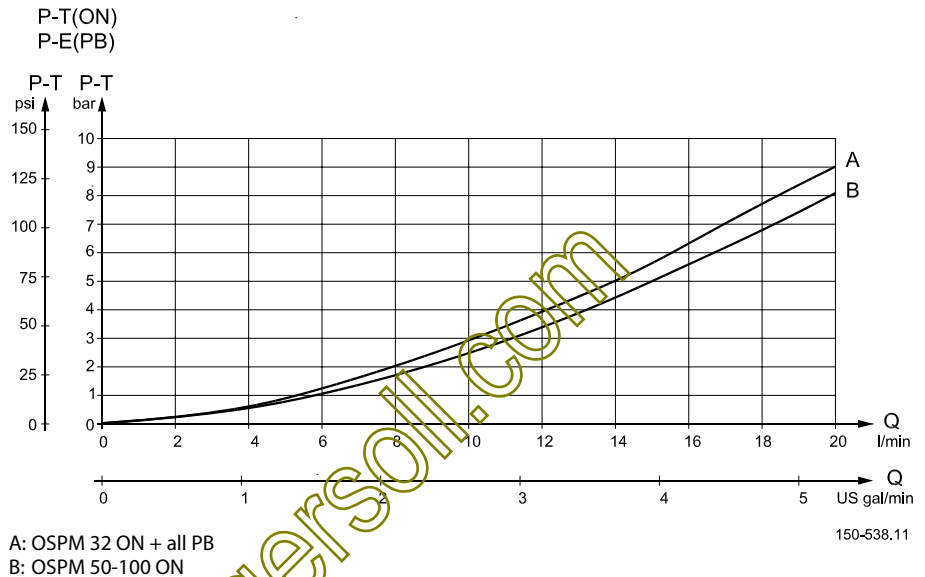

**PORT CONNECTIONS**

The connections of all OSPM-steering units in the catalogue are 9/16-18 UNF of the O-ring face seal type (ORFS).

The integrated end port fittings are specially developed for OSPM and therefore easily interchangeable.

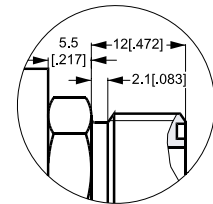

150-480.10

Dimensions of O-rings for ORFS ports:  
 7.65 × 1.78 mm [3.02 × 0.702 in] (SAE J515 seal size no.011).

Set of seals Sauer-Danfoss code no. 150L4042 contains 5 pcs. of these O-rings.

**DIMENSIONS OSPM**

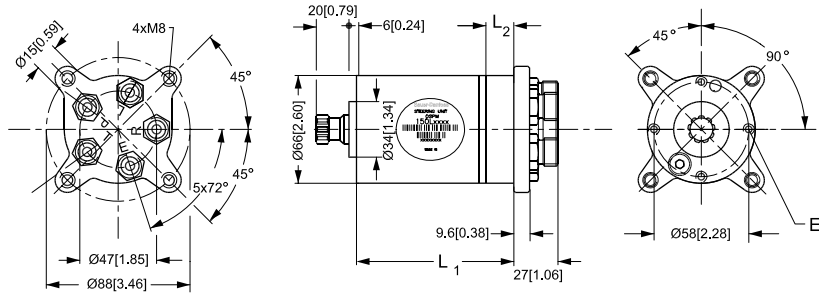

E: 4 × M6, 11 mm [0.432 in] deep

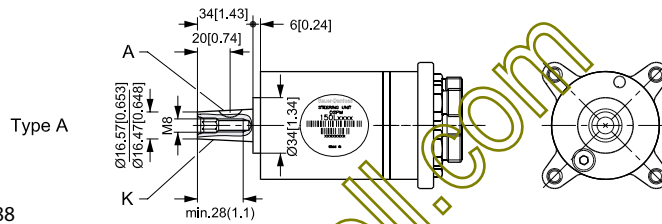

A: 5 × 6.5 DIN 6888  
 K: Taper 1:20

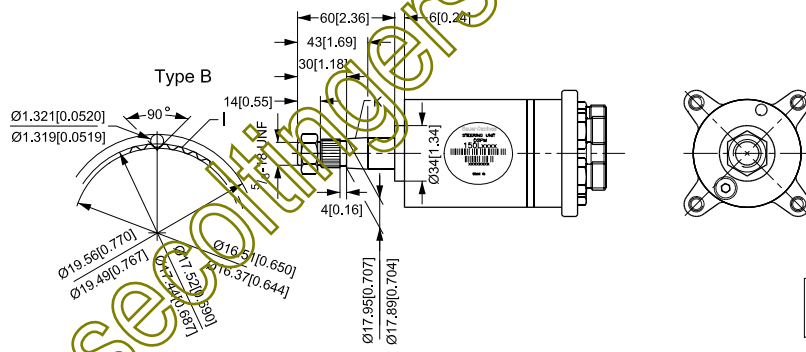

I: With 11/16 in - 40 serrations  
 $d_{min} = 17.92 \text{ mm [0.72 in]}$   
 K: Taper 1:12

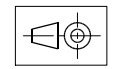

150-505.10

Mini steering unit	L1 mm	[in]	L2 mm	[in]
OSPM 32 ON	90	[3.54]	11.0	[0.43]
OSPM 40 ON	93	[3.66]	13.7	[0.54]
OSPM 50 ON	96	[3.78]	17.1	[0.67]
OSPM 63 ON	100	[3.94]	21.6	[0.85]
OSPM 80 ON	106	[4.17]	27.4	[1.08]
OSPM 100 ON	113	[4.45]	34.2	[1.35]
OSPM 32 PB	103	[4.06]	11.0	[0.43]
OSPM 50 PB	109	[4.29]	17.1	[0.67]
OSPM 63 PB	113	[4.45]	21.6	[0.85]
OSPM 80 PB	119	[4.69]	27.4	[1.08]
OSPM 100 PB	126	[4.96]	34.2	[1.35]

**TECHNICAL DATA**

**LOAD ON INTEGRATED STEERING COLUMN**

Symbols:  
 L (m/in): Axial length between OSPM housing and steering wheel  
 $F_r$  (N/lb): Radial force on steering wheel  
 $F_a$  (N/lb): Axial force on steering wheel  
 $M_B$  (Nm/lbf-in): Bending moment on steering column  $M_B = F_r \times L$

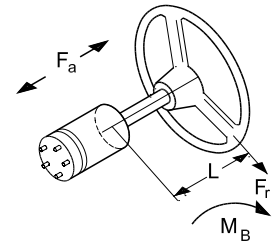

150-477.10

The following max. permissible values must not be exceeded:

$M_B$  max.: 50 Nm [438 lbf-in]  
 $F_r$  max.: 500 N [112 lb]  
 $F_a$  max.: 600 N [135 lb]

With a given length L the max. force  $F_r$  on the steering wheel can be calculated:

$$F_r = \frac{M_B \text{ max}}{L + 0.015} \quad \text{N; L in m}$$

$$F_r = \frac{M_B \text{ max}}{L + 0.590} \quad \text{lb; L in inch}$$

**LOAD ON SEPARATE STEERING COLUMN**

The construction of the steering column must ensure that no axial or radial forces are transferred to the steering unit. Such forces may prevent the steering unit from returning to neutral position automatically after a steering action has been completed.

The steering column must be supported.

The following max. permissible values for Sauer-Danfoss steering columns OTPM and OTPM-T must not be exceeded:

$M_B$  max.: 200 Nm [1752 lbf-in]  
 $F_a$  max.: 1000 N [224 lb]

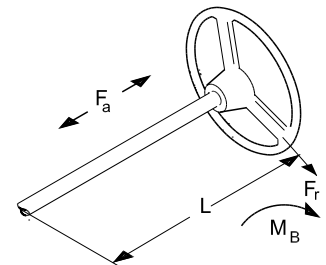

150-271.10

**INSTALLING THE STERING COLUMN**

Max. tightening torque for fixing screws:  $10^{+3}_0$  Nm [ $88^{+27}_0$  lbf.in]

Recommended tightening torque for the nut on the steering wheel connection is:

M 14 nut:  $35 \pm 5$  Nm [ $310 \pm 44$  lbf.in]

M 18 nut:  $40 \pm 5$  Nm [ $354 \pm 44$  lbf.in]

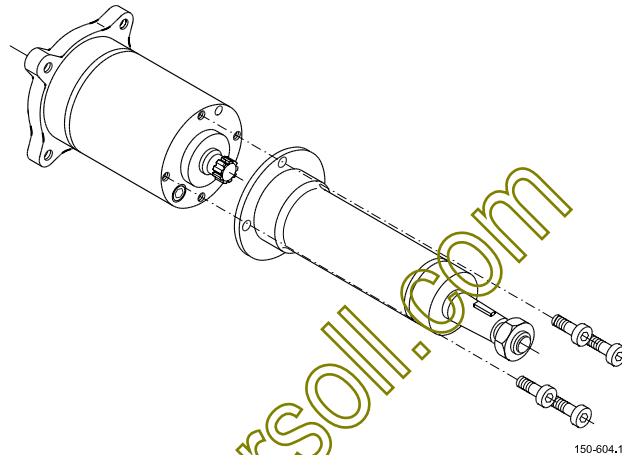

150-604.10

**SPLINED TUBE SECTION FOR STEERING COLUMNS**

Customers who wish to construct their own steering column can purchase splined tube sections from Sauer-Danfoss.

Code no. 150L0387.

When constructing your own steering column, please observe the following points:

1. Make sure, that the distance from mounting surface of the steering column to end of splined tube section and other dimensions of steering column are correct, so that engagement with the Sauer-Danfoss steering unit is as it should be (see page 18).
2. There must be only one bearing in the steering column (at the top).
3. The welded splined tube section must be coaxial with the steering column.
4. The steering column must be coaxial with the spigot hole  $\varnothing 35$  [1.38 in] (see page 18)

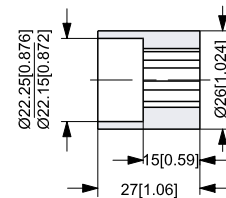

150-541.10

Splined tube section material:  
 Structural steel (St. 52-3, W.no. 1.0570).

We recommend CO<sub>2</sub> welding.



**VERSIONS**

OTPM and OTPM-T steering columns are suitable for OSPM steering units made for flanged-on steering columns.

OTPM steering columns are supplied in three different versions (M1, M2 and M3). Two with serrations and one with woodruff key. The steering columns are available in two standard lengths.



P300015.TIF

OTPM-T steering columns are supplied in one version (M3).  
 OTPM-T can be adjusted in steps of 5°, totally 40° from -25° against the driver, +15° away from the driver.  
 By spring release the upper part tilts away from the driver.



P300019.TIF

**CODE NUMBERS AND WEIGHTS**

Type		Code number		
		OTPM 163	OTPM 350	OTPM-T 131
C-dim. (See page 18)	mm [in]	163 [6.42]	350 [13.78]	-
B-dim. (See page 19)	mm [in]	-	-	84 [3.31]
E-dim. (See page 19)	mm [in]	-	-	47 [1.85]
Weight	kg [lb]	1.3 [2.9]	1.8 [4.0]	2.7 [5.95]
M1*)	With woodruff key 5 × 6,5 d <sub>min</sub> = 16,52 mm [0.65 in] Taper 1:20	150L1024	150L1025	-
M2*)	With serrations 7/8 in - 36, d <sub>min</sub> = 21,55 mm [0.85 in] Taper 1:19,26	150L1026	150L1027	-
M3*)	With serrations 1 1/16 in - 40, d <sub>min</sub> = 17,92 mm [0.71 in] Taper 1:12	150L1028	150L1029	150L1100

\*) The numbers refer to the dimensioned sketch on page 18.

The steering column must be supported.

For information on other versions of OTPM and OTPM-T steering columns, please contact the Sauer-Danfoss Sales Organization.

**DIMENSIONS**

**OTPM  
 STEERING COLUMNS,  
 TYPES M1, M2, M3**

**Type M1**

A: 5 × 6.5 DIN 6888  
 $d_{\min} = 16.52 \text{ mm [0.65 in]}$   
 K: Taper 1:20

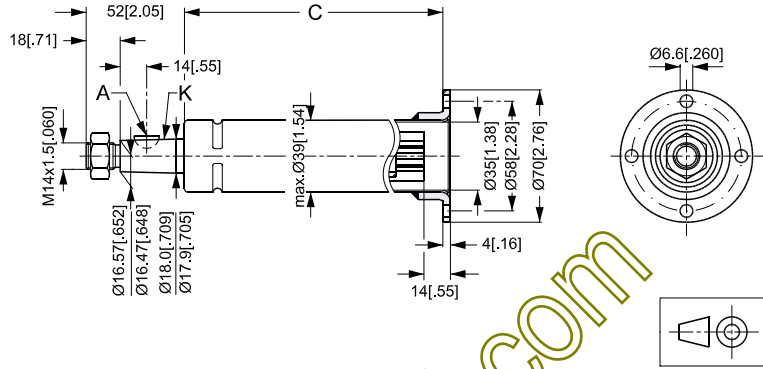

150-506.10

**Type M2**

With  $\frac{7}{8}$  in-36 serrations  
 $d_{\min} = 21.55 \text{ mm [0.85 in]}$   
 K: Taper 1:19.26

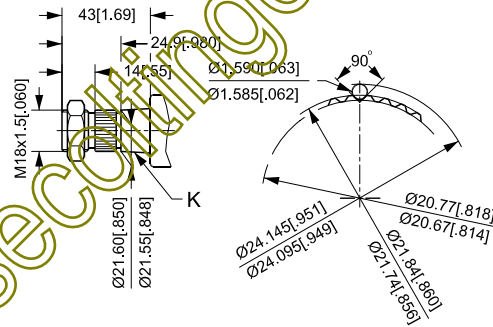

150-483.10

**Type M3**

With  $\frac{11}{16}$  in-40 serrations  
 $d_{\min} = 17.92 \text{ mm [0.71 in]}$   
 K: Taper 1:12

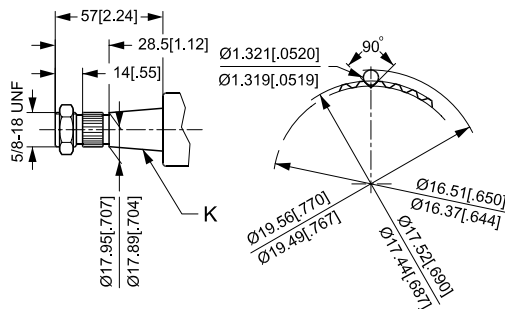

150-484.10

**DIMENSIONS**

**OTPM-T  
 STEERING COLUMNS**

**Type M3**

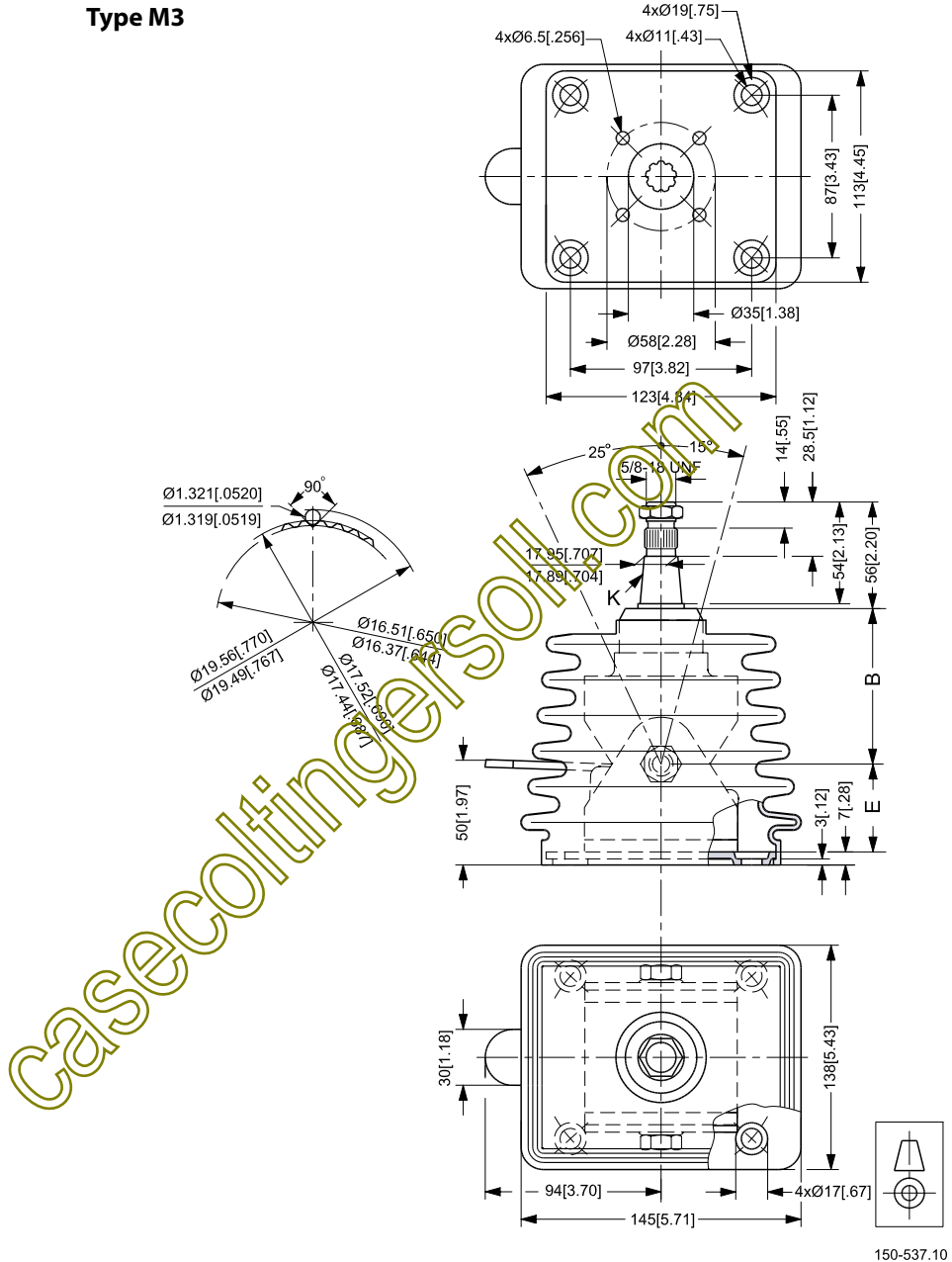

With <sup>11</sup>/<sub>16</sub> in-40 serrations  
 $d_{min} = 17.92 \text{ m} [0.71 \text{ in}]$   
 K: Taper 1:12

## OUR PRODUCTS

Hydrostatic transmissions  
Hydraulic power steering  
Electro hydraulic power steering  
Electric power steering  
Closed and open circuit axial piston pumps and motors  
Gear pumps and motors  
Bent axis motors  
Orbital motors  
Transit mixer drives  
Planetary compact gears  
Proportional valves  
Directional spool valves  
Cartridge valves  
Hydraulic integrated circuits  
Hydrostatic transaxles  
Integrated systems  
Fan drive systems  
Electrohydraulic controls  
Digital electronics and software  
Electric motors and inverters  
Sensors

## Sauer-Danfoss Hydraulic Power Systems – Market Leaders Worldwide

Sauer-Danfoss is a comprehensive supplier providing complete systems to the global mobile market.

Sauer-Danfoss serves markets such as agriculture, construction, road building, material handling, municipal forestry, turf care, and many others.

We offer our customers optimum solutions for their needs and develop new products and systems in close cooperation and partnership with them.

Sauer-Danfoss specializes in integrating a full range of system components to provide vehicle designers with the most advanced total system design.

Sauer-Danfoss provides comprehensive worldwide service for its products through an extensive network of Authorized Service Centers strategically located in all parts of the world.

Sauer-Danfoss (US) Company  
2800 East 13th Street  
Ames, IA 50010, USA  
Phone: +1 515 239-6000, Fax: +1 515 239-6618

Sauer-Danfoss (Neumünster) GmbH & Co. OHG  
Postfach 2460, D-24531 Neumünster  
Krokamp 35, D-24539 Neumünster, Germany  
Phone: +49 4321 871-0, Fax: +49 4321 871-122

Sauer-Danfoss ApS  
DK-6430 Nordborg, Denmark  
Phone: +45 7488 4444, Fax: +45 7488 4400